

Value added course **Intellectual Property Rights**

Chapter - 1



What we are going to discuss

Introduction on IPR

Why we learn IPR

Kinds of IPR

IPR in India

IPR in abroad

Major International agreements

Intellectual Property (IP) - Introduction

- ✓ **IP means the property, which is created with intellect such as inventions, books, paintings, songs, symbols, names, images, or designs used in business, etc.**

- ✓ **IP, like any real property that**
 - ❖ **Can be bought, sold, licensed, exchanged, given away**
 - ❖ **The owner can prevent unauthorized use and can take legal action, in case someone else uses it without permission.**

- ✓ **Legal rights conferred on such property are called “Intellectual Property Rights” (IPRs).**

- ✓ **These rights are outlined in Article 27 of the Universal Declaration of Human Rights, which provides for the right to benefit from the protection of moral and material interests resulting from authorship of scientific, literary or artistic productions.**

Need of Intellectual Property (IP)

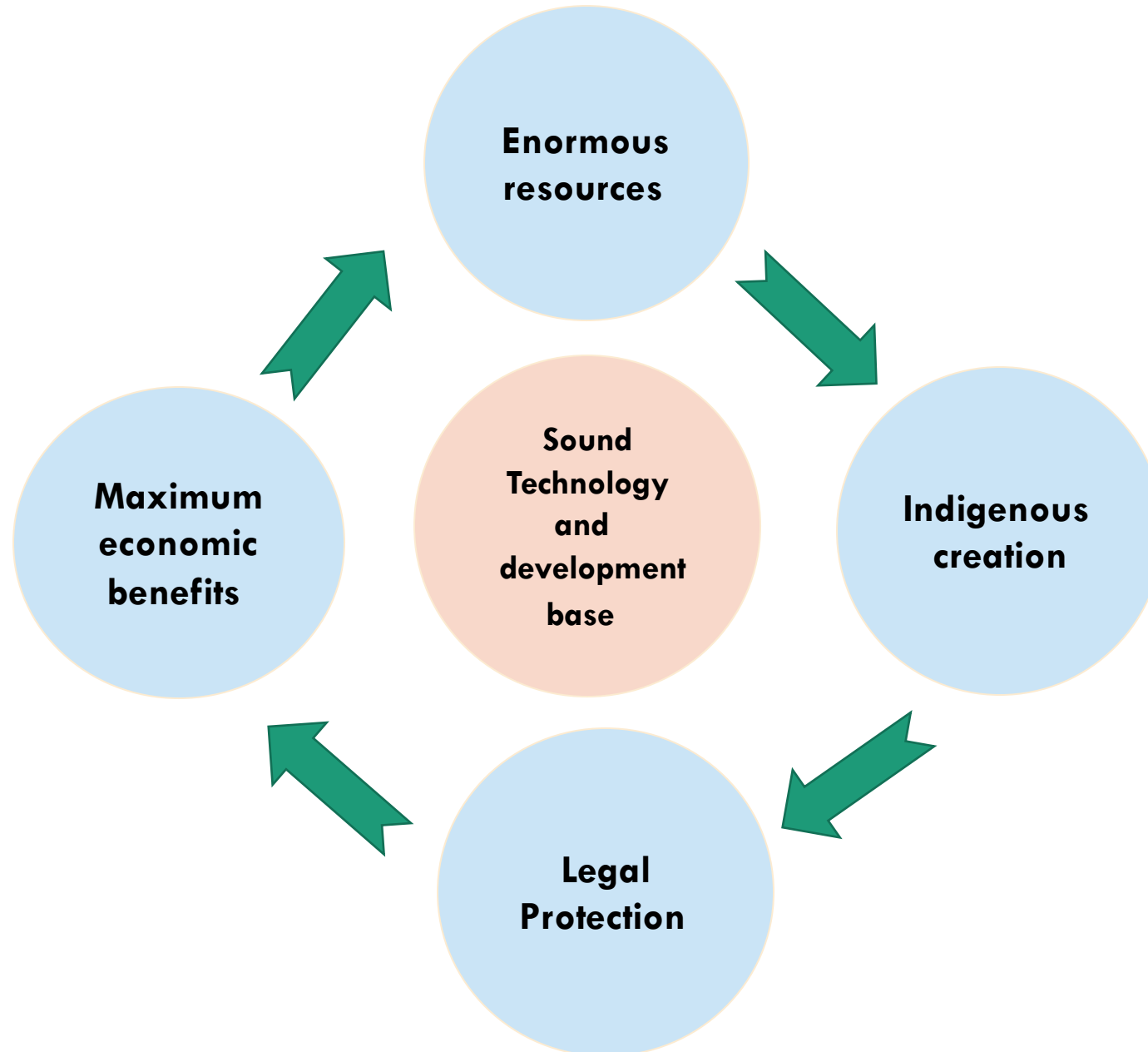

Need of Intellectual Property (IP)

- ✓ **Intellectual Property Rights (IPR) have become important in the face of changing trade environment such as**
 - global competition**
 - high innovation risks**
 - short product cycle**
 - need for rapid changes in technology**
 - high investments in research and development (R&D)**
 - highly skilled human resources**

- ✓ **With the opening of trade in goods and services, there is an possibility of infringement leading to inadequate return to the creators of knowledge**

- ✓ **IPR ensure R&D costs and other costs associated with introduction of new products are recovered and enough profits are generated in the market**

Need to learn Intellectual Property (IP)

- ✓ **Intellectual property rights deal with largely three things:**
 - about the rights**
 - the creation of those rights**
 - its enforcement**

- ✓ **When you working on a team that invents something—that has potential commercial value. A basic understanding of the legal basis of IP can prepare to make the best choices involved with a commercialisable invention**

- ✓ **IP has become the new watchword in almost any career. Look around and find imprint of IP everywhere**

- ✓ **As a result, any person today who does not understand at least the basics of intellectual property and its value and role in science, business, arts, and the professions will find him or herself at a distinct disadvantage in the world of tomorrow**



IP



INDIVIDUALS



SCHOOLS



COLLEGES



UNIVERSITIES



RESEARCH LABS



COMPANIES

Do you watch this?

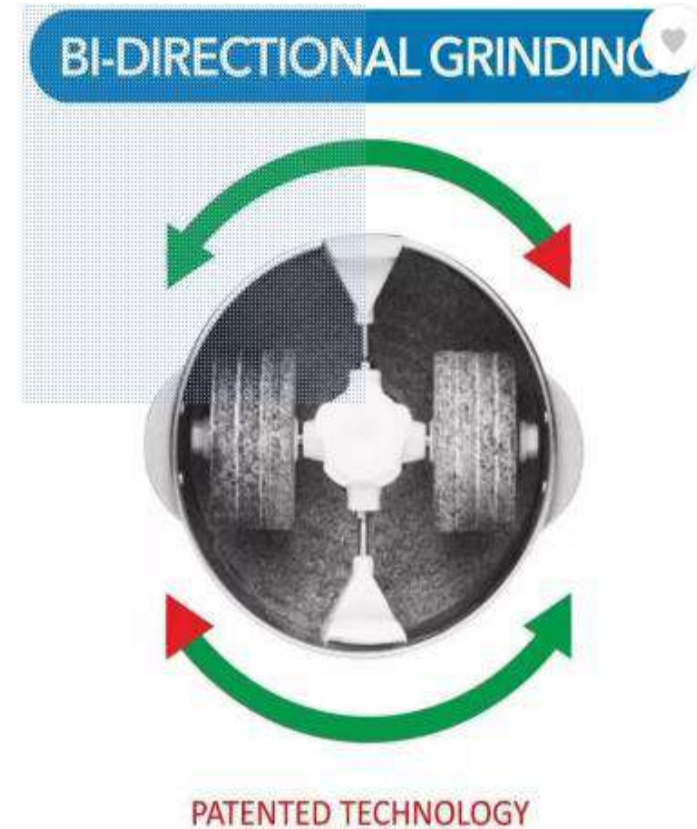

Terminology

A Patent gives monopolistic rights to its owner to exclude others, from making, using, selling, offering for sale or importing the product or the process for producing the product without his consent



Patents

What?

Any product or process which is new, non-obvious and capable of industrial application can be patented. The term of every patent in India is twenty years from the date of filing the Patent application

Do you watch this?



Terminology

Industrial Designs are the features of shape, configuration, pattern, ornament or composition of lines or colours applied to the product which makes it look different from other articles in the market.

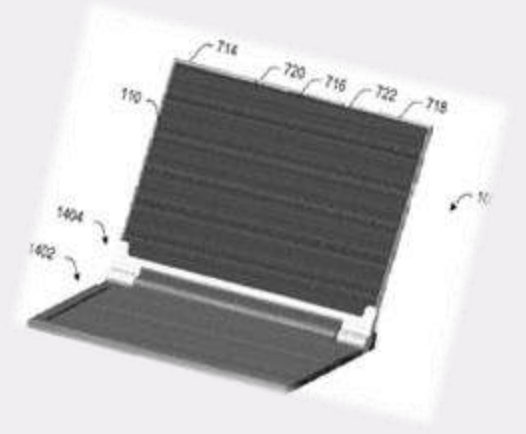

What?

The design must be new and distinct. The design protection is provided for 10 years. The period of protection is extendable to 5 years after the expiry of 10 years' duration.



Do you watch this?

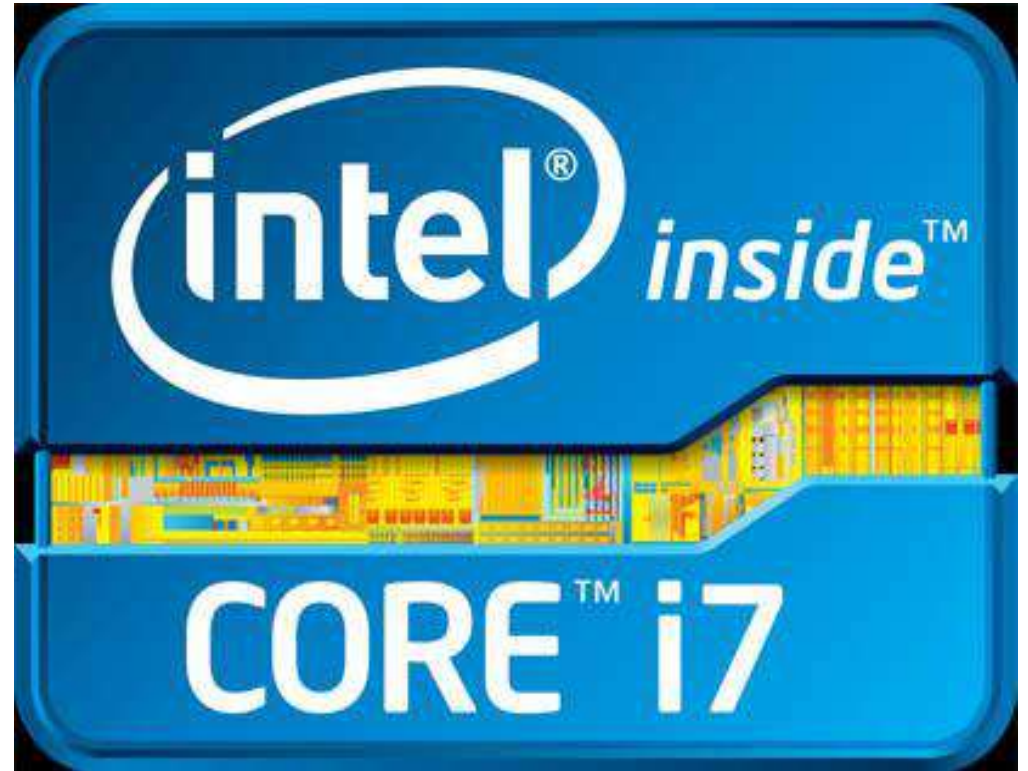

Terminology

TM ®

Trademark is a mark accorded with protection, intended to serve the purpose of recognizing the source/origin of the goods or services to which the particular mark belongs.



What?

A trademark is a mark which is unique, distinctive, made up of names, symbols, signs etc., and capable of distinguishing one product from another. Term of registration of a trademark is ten years, which may be renewed for a further period of ten years on payment of prescribed renewal fees.



Trademarks

Do you watch this?



01

Terminology

Copyright is an exclusive legal right protects “original works of authorship” that are fixed in “a tangible form of expression.” Copyright owner has rights to reproduce, translate, adapt, perform, distribute and publicly display the work, etc.



Lifetime of author + 60 years after death

60 years from publication

02

What?

Literary including Software, Artistic, Dramatic, Musical, Sound Recording, Cinematograph Films fall into copyrightable works



Copyrights

Do you watch this?



Terminology

Geographical indications of goods are defined as that aspect of industrial property which refer to the geographical indication referring to a country or to a place situated therein as being the country or place of origin of that product



10 Years + Renewal for other 10 years

What?

Geographical Indication is primarily an agricultural, natural or a manufactured product (handicrafts and industrial goods) originating from a definite geographical territory.



Do you watch this?



**PROTECTION OF PLANT VARIETIES
AND
FARMERS' RIGHTS AUTHORITY
MINISTRY OF AGRICULTURE,
GOVT. OF INDIA**



Terminology

To provide an effective system for protection of Plant varieties and rights of farmers and plant breeders.

To recognize the farmers in respect of their contributions

What?

**New Variety,
Derived
Variety**

**Trees & Vines
– 18 years;
Other Crops
– 15 years**



Plant protection

Do you watch this?

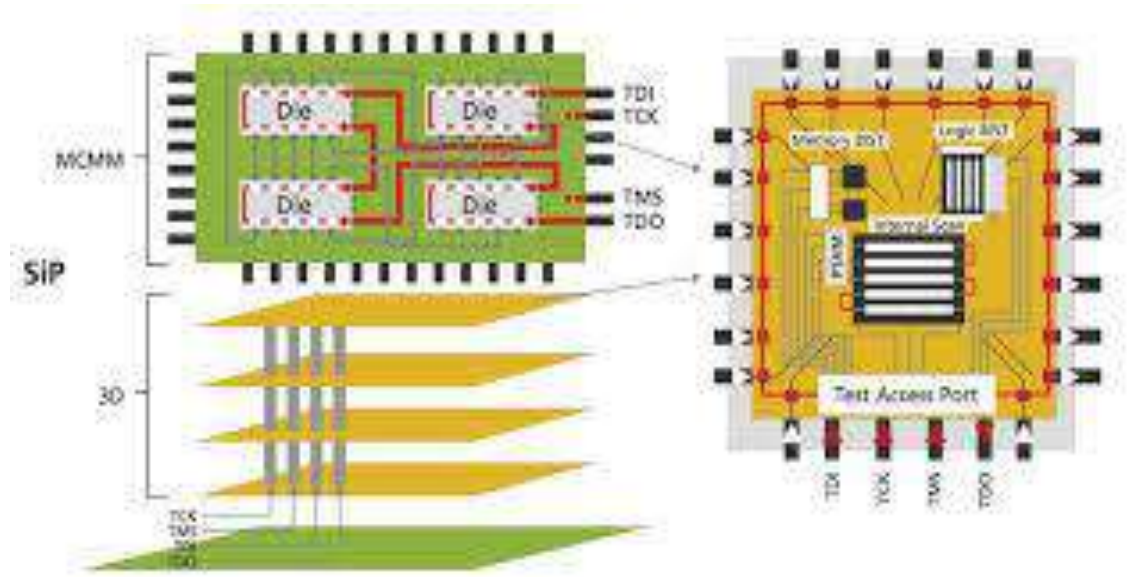
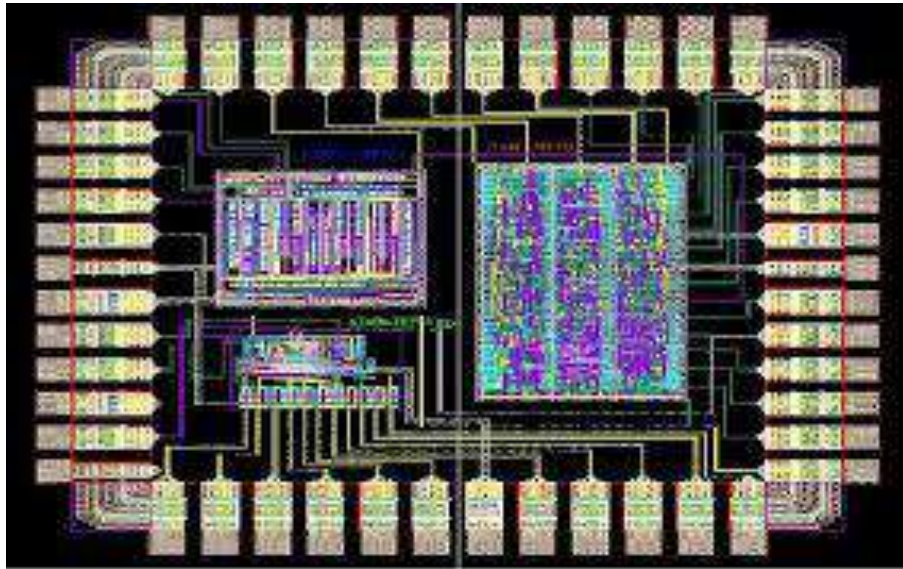

10 Years

Terminology

**Protection
provided for the
'layout-designs'
of a
semiconductor
integrated circuit**

What?

**Original,
Distinctive,
Capable of
distinguishing
from any other
layout design**



**Semiconductor
Layout design**

Do you watch this?



Genetic Resources & Traditional Knowledge

- **Genetic resources (GRs) refer to genetic material of actual or potential value**
- **Genetic material is any material of plant, animal, microbial or other origin containing functional units of heredity**
- **Traditional knowledge means the knowledge, systems, innovations and practices of local communities across the globe**

The Biological Diversity Act, 2002 was enacted for preservation of biological diversity in India, and provides mechanism for equitable sharing of benefits arising out of the use of traditional biological resources and knowledge





Traditional Knowledge Digital Library

Set up in 2001 by Council of Scientific and Industrial Research (CSIR) in collaboration with the **MINISTRY OF AYUSH**

Encourages modern research based on **Traditional Knowledge**

Maintains the ancient knowledge and traditionally passed verbal knowledge e.g., Knowledge about medicinal plants

Access given to several **International Patent Offices**

Wrong Patents in traditional knowledge are prevented from being granted - TKDL is an effective deterrent against bio-piracy

Translations available in 5 international languages i.e. English, Japanese, French, Spanish and German

3,00,000+ entries of traditional Indian medicinal systems of **Ayurveda, Unani, Siddha and Yoga**

Do you watch this?



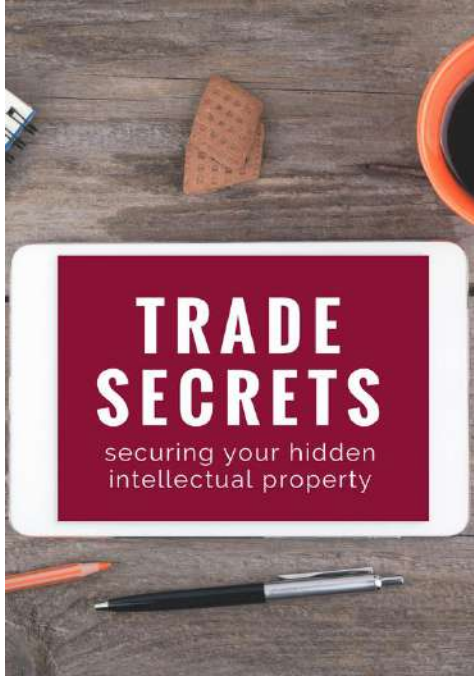

Trade Secrets

- **Any confidential business information which provides an enterprise a competitive edge may be considered a trade secret. Trade secrets encompass manufacturing or industrial secrets and commercial secrets**
- **Trade Secrets may include R&D Information, Software Algorithms, Inventions, Designs, Formulas, Financial Records, Ingredients, Lists of Customers, Devices, Methods, Consumer Profiles and Advertising Strategies or Policies of a Company, etc.**
- **A trade secret can be protected for an unlimited period of time**

Management or Commerce Students



How these studies will be useful to you?

- ✓ **There is an interesting analysis of how to convert limited life intellectual property into unlimited life intellectual property.**
- ✓ **Now, this is a key thing which manager should be acquainted.**
- ✓ **You need to manage the IP Portfolio of the company**
- ✓ **With because rights like patents, copyright, and designs, are called limited life IP. Whereas, trademarks and trade secrets are unlimited life. In the sense that there is no expiry date attached too so, managers are constantly looking at how they can convert a limited life IP into an unlimited life IP**



Careers
in
private.

Corporate
Offices,
R&D
Centers

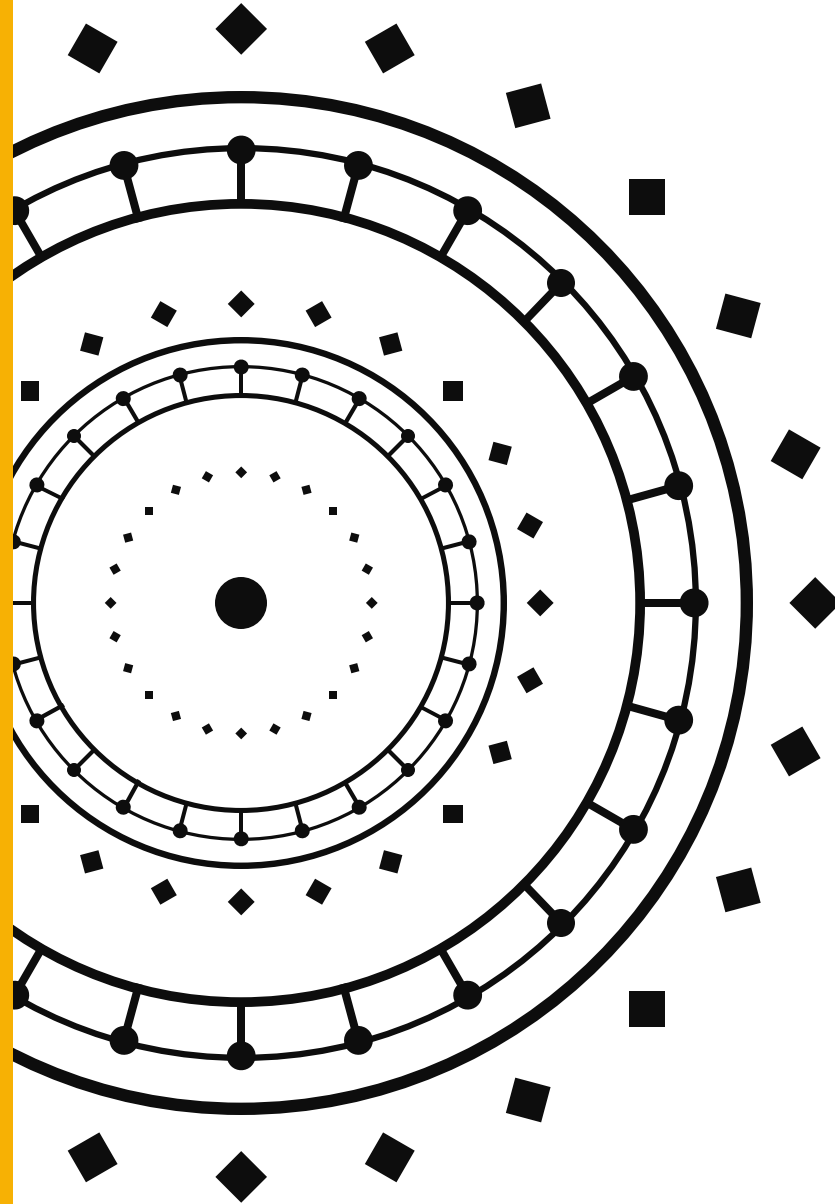

Patent
Docketing
officer

Patent
paralegal

Patent
Manager

What is your role here?

Manage the intellectual property assets by

- **Identification**
- **Patenting**
- **Licensing**
- **Marketing**
- **Reporting**

Develop appropriate commercialization strategies for intellectual property, including identifying prospective licensees through the use of information bases, discussions with inventors, and contacts obtained through industry affiliation.

Salary Package



About **2 lakh – 5 lakh p.a**

OTHERS...



01

Consultant

● IPR rules and regulations



Entrepreneur



02



IPR services ●

OTHERS...



03

Patent Agent

- Science / Technology Degree
- Patent act and rules
- Patent application drafting



Science / Technology Degree

Law Degree

Patent Attorney



04



Intellectual Property System – Indian Scenario

The Act VI of 1856 on protection of inventions based on the British Patent Law of 1852. Certain exclusive privileges granted to inventors of new manufacturers for a period of 14 years.



1856

1859

The Act modified as act XV Patent monopolies called exclusive privileges (making. Selling and using inventions in India and authorizing others to do so for 14 years from date of filing specification).

**The Patterns and
Designs Protection Act**

1872

1883

**The Protection of
Inventions Act**

**Consolidated as the
Inventions & Designs
Act**

1888

The Indian Patents and
Designs Act

1911



1970

Indian Patents Act

Amendment : 1999, 2002 and 2005

Other IP Acts in India

- ✓ **Designs Act, 2000**
- ✓ **Trademarks Act, 1999 (as amended)**
- ✓ **The Copyright Act, 1957 (as amended)**
- ✓ **The Geographical Indications of Goods (Registration & Protection) Act, 1999**
- ✓ **The Protection of Plant Varieties and Farmers' Rights (PPV&FR) Act, 2001**
- ✓ **Semiconductor Integrated Circuits Layout-Design Act, 2000**

Intellectual Property System – Global Scenario

- ✓ **The need for a system to protect IP internationally arose when foreign exhibitors refused to attend an International exhibition of inventions in Vienna in 1873 (because they are afraid that their ideas would be stolen and exploited commercially in other countries)**
- ✓ **This led to the creation of the Paris convention for the protection of Industrial property of 1883 (the Paris convention was the first major international treaty)**
- ✓ **In 1886, copyright entered the international arena with the Berne convention for the protection of literary and artistic works**
- ✓ **Both these convention set up international bureaux to carry out administrative tasks. In 1893, these two small bureaux united to form an international organisation called the United international bureaux for the protection of intellectual property, best known by its french acronym, BIRPI was the predecessor of WIPO**

Intellectual Property System – Global Scenario

- ✓ **The enforcement differences were a source of tension in international economic relations. Thus a need for harmonisation and predictability for disputes to be settled more systematically.**
- ✓ **Ideas and knowledge constitute an important part of trade. Creators have a right to prevent others from using their inventions, designs or other creations.**
- ✓ **WTO agreement on Trade Related Aspects of Intellectual Property Rights (TRIPS Agreement), which came into force in 1995, brought with new era in the multilateral protection and enforcement of IP rights.**
- ✓ **Provisions in the TRIPS agreement are concerning copyright and related rights, patents, trademarks, geographical indications, industrial designs and layout designs**



WIPO

WORLD
INTELLECTUAL PROPERTY
ORGANIZATION



सत्यमेव जयते

**Department of Commerce
Ministry of Commerce and Industry
Government of India**



सत्यमेव जयते

Department of Industrial Policy and Promotion
Ministry of Commerce and Industry
Government of India



INTELLECTUAL
PROPERTY **INDIA**

PATENTS | DESIGNS | TRADE MARKS
GEOGRAPHICAL INDICATIONS



Copyright Office
Government of India



Intellectual Property Appellate Board

Ministry of Commerce and Industry

Old (Department of Industrial Policy & Promotion)

New (Department for Promotion of Industry and Internal Trade)

From regulation and administration of the industrial sector, the role of the Department has been transformed into facilitating investment and technology flows and monitoring industrial development in the liberalised environment.

Strengthen the capabilities of the Intellectual Property Offices in India; to develop a vibrant Intellectual Property regime in the country.

Major International instruments concerning IPR

- ✓ **Paris Convention for the Protection of Industrial Property (1883)**
- ✓ **Berne Convention for the Protection of Literary and Artistic Works (1886)**
- ✓ **Universal copyright convention, 1952**
- ✓ **WIPO Convention, 1967**
- ✓ **Patent Cooperation Treaty (PCT) (1970)**
- ✓ **TRIPS (Trade related Intellectual Property Rights) Agreement, 1994**

Paris Convention for the Protection of Industrial Property (1883)

What?

Industrial property

- Patents
- Trademarks
- Industrial designs
- Utility models
- Service marks
- Trade names
- Geographical indications
- Repression of unfair competition

Terminology

National treatment (grant the same protection to nationals of other)

Right of priority (first application filed in one of the Contracting States apply for protection in any of the other – 12 months (Patents) 6 months (Designs))

Common rules (granted in different Contracting States for the same invention are independent of each other)

Outcomes

The Paris Convention does not regulate the conditions for the **filing and registration of marks (Administered by domestic law)**

1

Paris Union

Assembly and an Executive Committee

Every State that is a member of the Union

Executive Committee are elected from among the members of the Union, except for Switzerland, which is a member ex officio

Biennial program and budget of the WIPO Secretariat

2

- **Concluded : 1883**
- **Revised:**
 - Brussels in 1900**
 - Washington in 1911**
 - The Hague in 1925**
 - London in 1934**
 - Lisbon in 1958**
 - Stockholm in 1967**
- **Amended :1979**

Berne Convention for the Protection of Literary and Artistic Works (1886)

What?

Protection of works and the rights of their authors

Three basic principles

- National treatment
- Automatic protection
- Independence of protection

Terminology

Minimum standards

- Protection for every production in the literary, scientific and artistic domain in any form
- The right to translate, make adaptations and arrangements, perform in public, communicate to the public, broadcast, make reproduction
- Duration of protection (50 years after death of author)

Outcomes

Exceptions: Provide "free uses" for educational activities with due credits

1

Berne Union

Assembly and an Executive Committee

Every State that is a member of the Union

Executive Committee are elected from among the members of the Union, except for Switzerland, which is a member ex officio

Biennial program and budget of the WIPO Secretariat

2

- **Concluded : 1886**

- **Revised:**

 - Paris in 1896**

 - Berlin in 1908**

 - Rome in 1928**

 - Berlin in 1908**

 - Brussels in 1948**

 - Stockholm in 1967**

 - Paris in 1971**

- **Amended :1979**

Universal copyright convention, 1952

What?

Some countries disagree with Berne convention

UNESCO develops it as an alternative to the Berne Convention

United States

Russia (1973)

Terminology

The United States only provided copyright protection for a fixed, renewable term, and required that in order for a work to be copyrighted it **must contain a copyright notice and be registered at the Copyright Office**

Berne Convention, on the other hand, provided for copyright protection for a single term based on the life of the author, and **did not require registration or the inclusion of a copyright notice** for copyright to exist

WIPO Convention, 1967

What?

Constituent instrument of
**World Intellectual
Property Organization
(WIPO)**

Signed at Stockholm on July 14, 1967
Entered into force in 1970
Amended in 1979

Terminology

Two main objectives are

- (i)** to promote the protection of intellectual property worldwide; and
- (ii)** to ensure administrative cooperation among the intellectual property Unions established by the treaties that WIPO administers

Setting of norms, standards, international classification etc.,

Outcomes

1

- WIPO General Assembly
- WIPO Conference
- WIPO Coordination committee

Secretariat of the Organization is called the **International Bureau**. The executive head of the International Bureau is the **Director General**

2

Headquarters: Geneva, Switzerland

Other Offices:

- Brazil (Rio de Janeiro)
- Japan (Tokyo)
- Singapore (Singapore)
- United States of America (at the United Nations in New York)

Patent Cooperation Treaty (PCT) (1970)

What?

Seek patent protection by filing an **"International" patent application**

Treaty regulates the formal requirements of International applications

File your application in designated countries

Provides International search

Terminology

Advantages

- Brings the world within reach
- Evaluate possibility of patenting through International search report and written opinion
- Puts the world on notice of their applications

The PCT created a Union which has an Assembly. Every State party to the PCT is a member of the Assembly

TRIPS (Trade related Intellectual Property Rights) Agreement, 1994

What?

Member nations of the World Trade Organization (WTO)

- Copyright and related rights
- Trademarks
- Geographical indications
- Industrial designs
- Patents
- Protection of new varieties of plants
- Layout-designs of integrated circuits
- Undisclosed information

Terminology

Standards (subject-matter to be protected, the rights to be conferred and permissible exceptions to those rights, and the minimum duration of protection)

Enforcement (procedures and remedies)

Dispute settlement (WTO's dispute settlement procedures)

Links for Reference

World Intellectual Property Organisation

<http://www.wipo.int/portal/en/index.html>

Intellectual property India

<http://www.ipindia.nic.in>

Cell for IPR promotion and Management (CIPAM)

<http://cipam.gov.in/>

To know more...

Visit : <http://www.bdu.ac.in/cells/ipr/>

E-Books on IPR :

<http://www.bdu.ac.in/cells/ipr/docs/ipr-tamil-ebook.pdf> (Tamil)

<http://www.bdu.ac.in/cells/ipr/docs/ipr-eng-ebook.pdf> (English)

E-mail: iprcell@bdu.ac.in

Thanks for your Participation



Value added course

Intellectual Property Rights

Chapter - 2

Patents

Criteria of Patentability

Non-Patentable subject matter

Registration Procedure

Rights of Patentee

Assignment and Licence

Restoration, Surrender and Revocation of Patents

Infringement, Remedies and Penalties

Patent Office and Appellate Board

What we are going to discuss

Patents - Introduction



- ✓ **A patent can be defined as a grant of exclusive rights to an inventor over their invention for a limited period of time. The exclusive rights conferred include the right to make, use, exercise, sell or distribute the invention and excluding others to make use of it**
- ✓ **Patents are granted for a new product or process**
- ✓ **The term of a patent is twenty years, after the expiry of which, the invention would fall into the public domain**
- ✓ **A patent is valid within the territory of country where it is granted; however, protection can be availed in other countries by filing applications in relevant patent offices**

The present Patents Act, 1970 came into force in the year 1972. This Act has been amended two times since then, i.e., in 2002 and 2005

Only inventions are patentable

“An invention means a new product or process involving an inventive step and capable of Industrial application”

Indian Patents Act, 1970

Basic Structure of Patent

01
ABSTRACT
Crux of the invention



03
CLAIMS
Aspects to claim/monopolize



02
DESCRIPTION
Brief description of the invention



04
DRAWINGS
Image that best represents your invention



Criteria of Patentability

Novelty

It must be new, i.e. it is not something already existing in the current knowledge anywhere in the world, i.e. not in public domain in any form, before the filing of patent application.

Inventive Step

It must be non-obvious to any person who is skilled in the relevant field of technology. That is, the standard is a person reasonably skilled in such field of study and not a layman.

Industrial use

It must be capable of industrial application, i.e. capable of being applied to practical utilities and not just pure theory.



Other Characteristics of Patentability

Unity of invention

Claims in the application for patent must refer to the same inventive idea

Sufficiency of Disclosure

The complete specification (techno-legal document describing the invention) should disclose the invention completely so that a person skilled in the art can perform the invention by developing the necessary technical know-how

Our Patented Safety Interlock System

If the Dome is not placed securely in the Jar,
the machine will not work.
This is the essence of our safety
interlock system.



The dome and motor
are internally connected.
The motor will start
only when the dome
is securely placed in the Jar.



Patent - Examples

Section 3

Non - Patentable subject matter

**Contrary to
well
established
natural
laws**

**Contrary
to public
order**

**Discoveries
& Scientific
Theories**

**New form
of a
known
substance**

**Admixture
of
substances**

**Arrangement
or Duplication
of known
devices**

Without enhanced efficacy

**Only aggregation of
properties**

Section 3

Non - Patentable subject matter

**A method
of
Agriculture
or
Horticulture**

**Diagnostic,
Therapeutic
and Surgical
methods of
treatment for
humans or
animals**

**Plants, animals
and essentially
biological
processes for
production or
propagation of
plants and
animals**

Except microorganisms

**Mathematical
or business
method or a
computer
program**

**Method of
playing
game**

**Presentation
of
information**

Non - Patentable subject matter

Section 3

**Traditional
Knowledge or
aggregation of
traditionally
known
component**

Section 4

**Inventions
relating to
Atomic
energy**

Registration Procedure - India



- ✓ **Inventor may make an application, either alone or jointly with another, or his/their assignee or legal representative**
- ✓ **The filing of an application for a patent disclosing the invention would secure priority date of the invention**
- ✓ **Application is required to be filed according to the territorial limits where the applicant(s) for a patent normally resides or has domicile or has a place of business or the place from where the invention actually originated**

Patent Application

Provisional Specification -- Made even before the full details of working of the invention are developed (**Secure Priority date**)

Complete Specification -- Full details of the invention and claim section

Within
12 Months

Jurisdiction of Patent Offices, India

Office	Territorial Jurisdiction
Patent Office Branch, Mumbai	The States of Maharashtra, Gujarat, MadhyaPradesh, Goa and Chhattisgarh and the Union Territories of Daman and Diu & Dadra and Nagar Haveli
Patent Office Branch, Chennai	The States of Andhra Pradesh, Karnataka, Kerala, Tamil Nadu and the Union Territories of Pondicherry and Lakshadweep, Telangana
Patent Office Branch, New Delhi	The States of Haryana, Himachal Pradesh, Jammu and Kashmir, Punjab, Rajasthan, Uttar Pradesh, Uarakhand, Delhi and the Union Territory of Chandigarh.
Patent Office, Kolkata	The rest of India.



Documents required for filing an Application

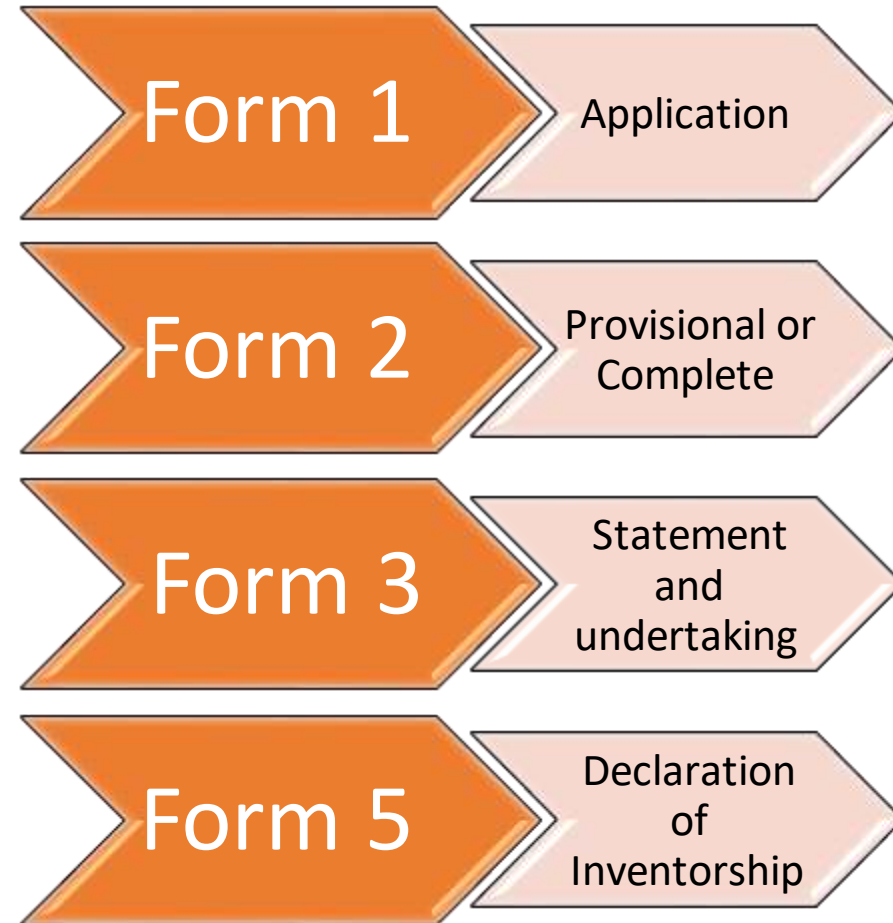

Patenting Process

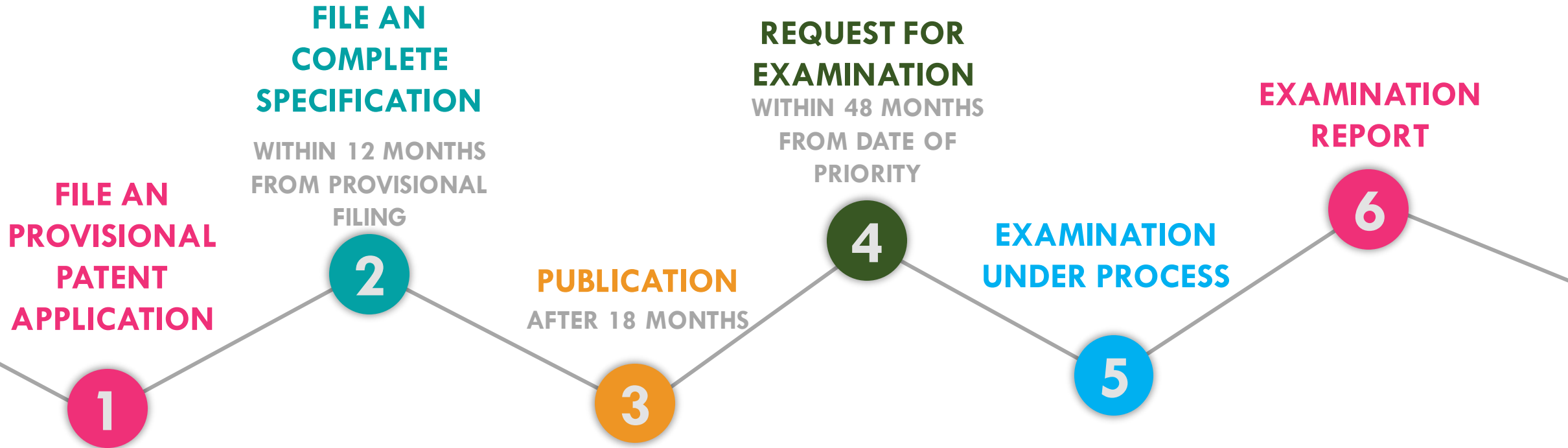

Patenting Process ...

**REPLY FOR
EXAMINATION
REPORT**

7

**REPLY WITHIN 6
MONTHS
(EXTENDABLE BY
3 MONTHS)**

MAXIMUM THREE
OFFICE ACTION

8

**CONTROLLER
HEARING**

9

**GRANT OF
PATENT**

10

Pre-grant Opposition

Where an application for a patent has been published but a patent has not been granted, any person may, file Form 7(A) by way of opposition to the Controller against the grant of any Patent

The Controller shall, if requested by such person for being heard, hear him and dispose of such representation

Post-grant Opposition

Any interested person can file notice of opposition by filing Form 7 any time after the grant of Patent but before the expiry of a period of one year from the date of publication of grant of a Patent in the Patent Office Journal

The post grant opposition is decided by an Opposition Board followed by a hearing and the reasoned decision by the Controller

Term of Patent

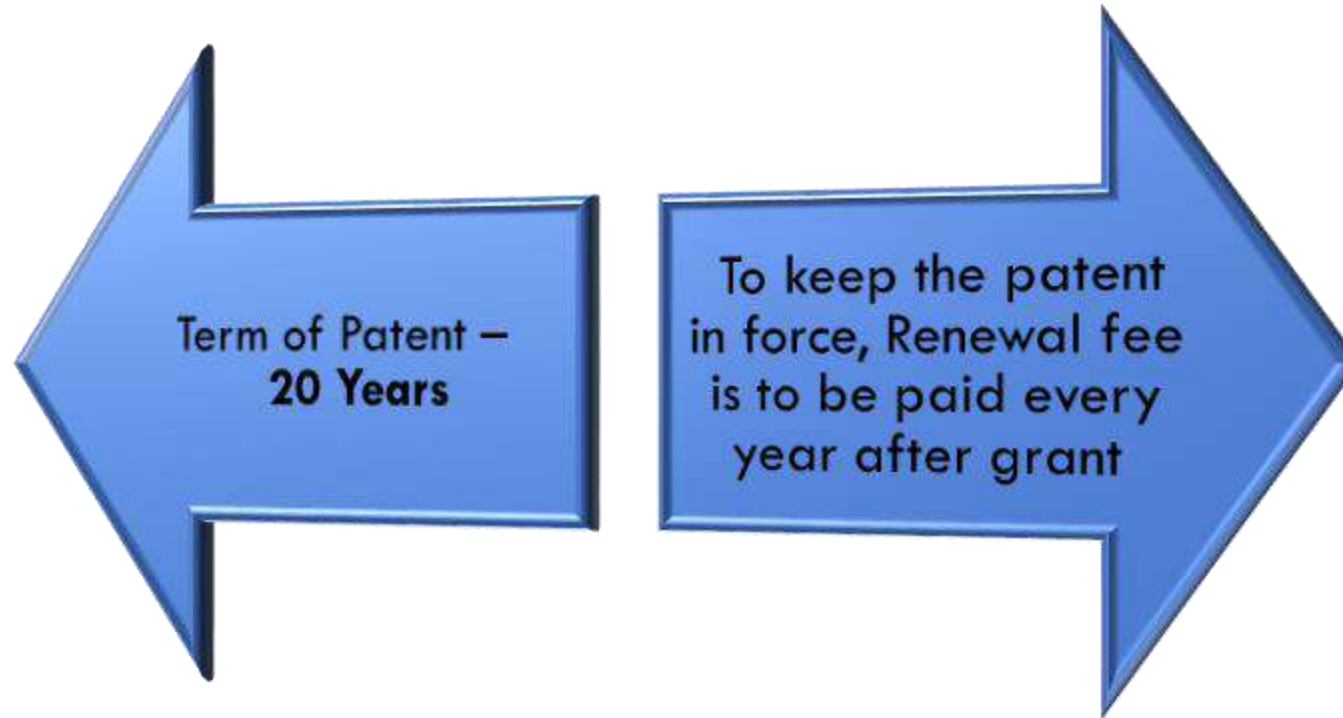

Application for restoration of a patent that lapses due to non-payment of renewal fees must be made within 18 months of lapse (**Form 15**)

Request for permission to file abroad

If any application is to be filed abroad, without filing in India, it should be made only after taking a written permission from the Controller

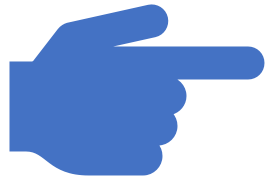

The request for permission for making patent application outside India shall be made in Form-25 along with a fee. A gist of invention should also be filed along with the Form-25

Registration Procedure – Convention Countries

Filing an convention application

An application for patent filed in the Patent Office, claiming a priority date based on the same or substantially similar application filed in one or more of the convention countries

In order to get convention status, an applicant should file the application in the Indian Patent Office within 12 months from the date of first filing of a similar application in the convention country

Registration Procedure - International

The Patent Cooperation Treaty is an international treaty with more than 150 Contracting States

The granting of patents remains under the control of the national or regional patent Offices in what is called the “national phase”

The PCT makes it possible to seek patent protection for an invention simultaneously in a large number of countries by filing a single “international” patent application instead of filing several separate national or regional patent applications

Filing of International Application

The Indian Patent Office at Delhi, Chennai, Mumbai or Kolkata as the Receiving Office (RO/IN)

OR

The International Bureau of WIPO as the Receiving Office (RO/IB)

A Request (Form PCT/RO/101) accompanied by description, claims, abstract (and drawings if required) of the invention in English or Hindi

Filing fee

International Search



Every international application is subject to international search by an International Searching Authority (ISA)

ISA establishes International Search Report (ISR) which identifies the published patent documents and technical literature (“prior art”) which may have an influence on whether the invention is patentable

**India is
one of the
ISA**

ISA also establishes Written Opinion of Search Authority (WOSA) on the invention’s potential patentability

Publication

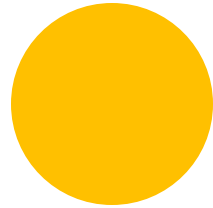
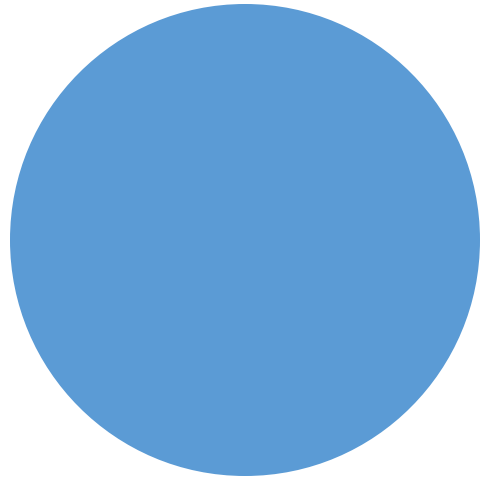

**International application along with
International Search Report is published by WIPO**

**After expiry of 18 months
from the priority date
of the application**

International Preliminary Examination

After establishment of ISR/WOSA and publication by WIPO, the applicant may opt for International Preliminary Examination (IPE). IPEA establishes International Preliminary Report on Patentability (IPRP)

File (Form PCT/IPEA/401) for international preliminary examination with fees

If the applicant does not opt for IPE, the International Bureau of WIPO publishes the WOSA as International Preliminary Report on Patentability

National Phase

Before 30/31 months from the priority date, applications for the grant of patents can be filed before the national (or regional) patent offices of the countries in which patent protection is desired

Patent term of 20 years begins from International filing date

Rights of the Patentee

Product

The patentee has the exclusive right to prevent others from performing, without authorisation, the act of making, using, offering for sale, selling or importing that product for the above purpose

Process

The patentee has the exclusive right to exclude others from performing, without their authorisation, the act of using that process, using and offering for sale, selling or importing for those purposes, the product obtained directly by that process in India

Assignment

A patentee may assign the whole or any part of the patent rights

Kinds of assignments:

- ✓ **Legal assignment** (agreement to assign – Assignee (Patent Owner))
- ✓ **Equitable assignment** (certain share given to another person)
- ✓ **Mortgages** (patent rights are transferred to obtain money)

A valid assignment under the Patents Act requires the assignment to be in writing, to be contained in a document that embodies all terms and conditions and must be submitted within six months

Licence



Exclusive Licence means that no person or company other than the named licensee can exploit the relevant intellectual property rights. Importantly, the licensor is also excluded from exploiting the intellectual property rights

Non-Exclusive Licence grants to the licensee the right to use the intellectual property, but means that the licensor remains free to exploit the same intellectual property and to allow any number of other licensees to also exploit the same intellectual property

<i>Assignment</i>	<i>Licensing</i>
The party "selling" the IP: assignor The party "buying" the IP: assignee	The party "renting out" the IP: licensor The party "renting in" the IP: licensee
The owner of IP changes and becomes the assignee.	The owner of IP does not change and remains the licensor.
An assignment is a permanent transfer of rights.	A licence is a temporary transfer of certain rights.

Compulsory Licence

To prevent the abuse of patent as a monopoly and to make way for commercial exploitation of an invention by an interested person

Any person can make an application for grant of a compulsory license for a patent after three years, from the date of grant of that patent, on any of the following grounds:

- The reasonable requirements of the public with respect to the patented invention have not been satisfied**
- The patented invention is not available to the public at a reasonably affordable price**
- The patented invention has not worked in the territory of India**

Surrender of Patents

A patentee may, at any time by giving notice to the Controller, offer to surrender the patent

Where such an offer is made, the Controller shall publish the offer

Any person interested may, within the prescribed period after such publication, give notice to the Controller of opposition to the surrender

If the Controller is satisfied after hearing the patentee and any opponent, if desirous of being heard, that the patent may properly be surrendered and, by order, revoke the patent

Revocation of Patents



Patents may be revoked

- ✓ on a petition of any person interested or
- ✓ of the Central Government by the Appellate Board or
- ✓ on a counter-claim in a suit for infringement of the patent by the High Court

Revocation grounds

- ✓ **Invention claim is already present in the granted patent**
- ✓ **Patent was obtained wrongfully**
- ✓ **Subject of any claim of the complete specification is not an invention**
- ✓ **The invention so far as claimed in any claim of the complete specification is not new**
- ✓ **The invention so far as claimed in any claim of the complete specification is obvious**

Revocation grounds

- ✓ **That the invention, so far as claimed in any claim of the complete specification, is not useful**
- ✓ **Complete specification does not sufficiently and fairly describe the invention**
- ✓ **Scope of any claim of the complete specification is not sufficiently and clearly defined**
- ✓ **Subject of any claim of the complete specification is not patentable**

Revocation grounds

- ✓ **Applicant for the patent has failed to disclose to the Controller the information or false information**
- ✓ **Applicant contravened any direction for secrecy**
- ✓ **Amend the complete specification was obtained by fraud**
- ✓ **The complete specification does not disclose or wrongly mentions the source or geographical origin of biological material**

Revocation grounds

- ✓ **Claimed in any claim of the complete specification having regard to the knowledge, oral or otherwise, available within any local or indigenous community in India or elsewhere**
- ✓ **Where the Central Government is of opinion that a patent or the mode in which it is exercised is mischievous to the State or generally prejudicial to the public, after hearing the patent shall be deemed to be revoked**

Patent Infringement

The Indian Patent Act does not specifically define activities that constitute infringement of patent rights

But there is an exclusive rights upon the patentee to exclude third parties from making, importing, using, offering for sale or selling the patented invention

Violation of aforementioned monopoly rights would constitute infringement of patent



Remedies



Administrative Remedy

When infringing goods are imported into Indian territory, the IP owner can approach the collector of customs and prevent the entry of these goods into the Indian market. The IP owner must provide the name of the exporter, consignee, port of entry, name of the ship, etc., to avail their remedy

Remedies



Civil Remedy

1. Interim Injunctions - During the pendency of the case before a full-fledged trial
2. Permanent Injunctions - Full-fledged trial

Penalties

The penalty that a court may grant in any suit for infringement includes an injunction and at the option of Plaintiff, either damages or an account of profits



Damages or accounts of profits shall not be granted against the defendant who proves that at the date of infringement they were not aware and had no reasonable grounds for believing that that the patent existed

Intellectual Property Appellate Board (15th September 2003)



Strengthened IPAB(Intellectual Property Appellate Board, Chennai) will directly contribute to the growth of a stronger IPR regime and indirectly in the growth of economic development



It hear appeals against the decisions of the Registrar of Trade Marks and Geographical Indications and Controller of Patents

Links for Reference

World Intellectual Property Organisation

<https://www.wipo.int/patents/en/>

Controller General of Patents, Designs and Trademarks

<http://www.ipindia.nic.in/patents.htm>

Cell for IPR promotion and Management (CIPAM)

<http://cipam.gov.in/know-your-ip-2/patents/>

To know more...

Visit : <http://www.bdu.ac.in/cells/ipr/>

E-Books on IPR :

<http://www.bdu.ac.in/cells/ipr/docs/ipr-tamil-ebook.pdf> (Tamil)

<http://www.bdu.ac.in/cells/ipr/docs/ipr-eng-ebook.pdf> (English)

E-mail: iprcell@bdu.ac.in

Thanks for your Participation



Value added course

Intellectual Property Rights

Chapter - 3

What we are going to discuss

Copyright -Introduction

Subject matter of Copyright

Registration Procedure

Ownership of Copyright

Assignment and licence of Copyright

Infringement, Remedies &Penalties

Related Rights

D/B Related rights and Copyrights



Copyright - Introduction

- ✓ **Copyright is granted to the creators of original works of authorship such as literary works (including computer programs, tables and compilations including computer databases which may be expressed in words, codes, schemes or in any other form, including a machine readable medium), dramatic, musical and artistic works, cinematographic films and sound recordings**
- ✓ **Copyright law protects expressions of ideas rather than the ideas themselves**
- ✓ **Copyright protection commences the moment a work is created, and its registration is optional. However, it is always advisable to obtain a registration for a better protection**
- ✓ **Copyright registration does not confer any rights and is merely a prima facie proof of an entry in respect of the work in the Copyright Register maintained by the Registrar of Copyrights**

The Copyright Act, 1957

- ✓ **The Copyright Act, 1957 came into effect from January 1958. This Act has been amended five times since then, i.e., in 1983, 1984, 1992, 1994, 1999 and 2012**
- ✓ **It protects the writer or creator of the original work from the unauthorized reproduction or exploitation of their materials**

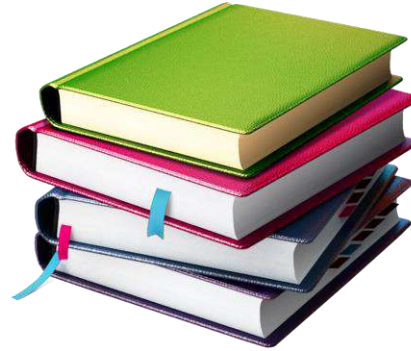

Subject matter of Copyright



Literary including Software – Books, Essay, Compilations, Computer Programs



Artistic – Drawing, Painting, Logo, Map, Chart, Photographs, Work of Architecture



Dramatic – Screenplay, Drama



Musical – Musical Notations

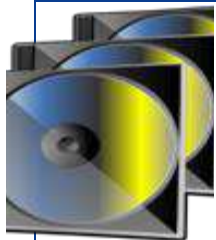

Sound Recording – Compact Disc

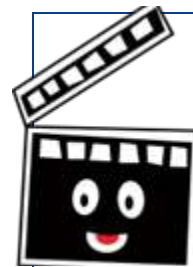

Cinematograph Films – Visual Recording which includes sound recording

Literary work

- ✓ **Copyright subsists in original literary works and relates to the expression of thought, but the expression need not be original or novel**
- ✓ **The work must not be copied from another work but must originate from the author**
- ✓ **The emphasis is more on the labour, skill judgement and capital expended in producing the work**
- ✓ **It includes tables, compilations and computer programs**

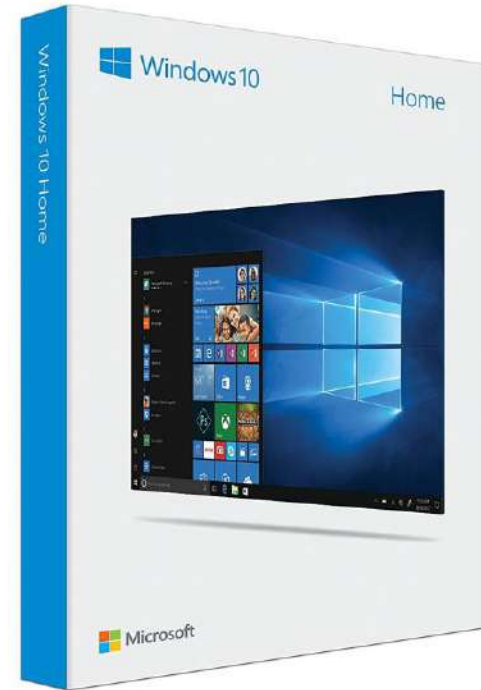
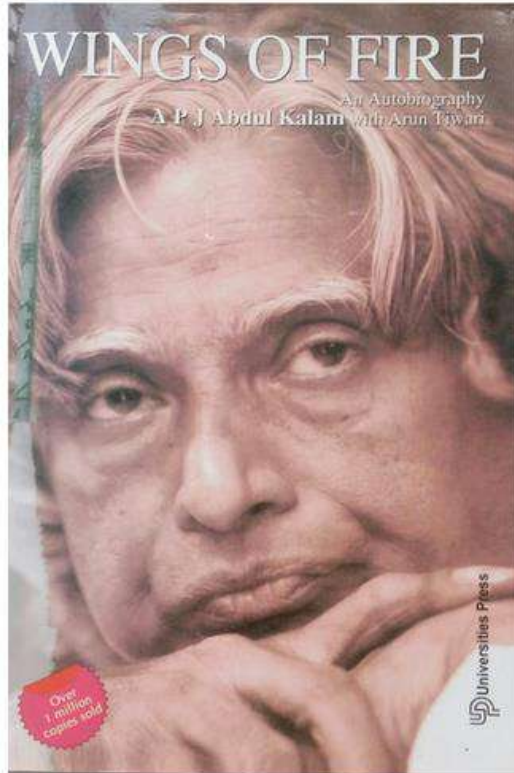

Examples (Literary work)

Dramatic work

- ✓ Copyright subsists in original dramatic work and its adaptation
- ✓ It includes any piece or recitation, choreographic work
- ✓ Entertainment in dumb show
- ✓ The scenic arrangement or acting form of which is fixed in writing otherwise
- ✓ But does not include a cinematograph film



Musical work

- ✓ **Copyright subsists in original musical work**
- ✓ **Includes any combination of melody and harmony, either of them reduced to writing or otherwise graphically produced or reproduced**
- ✓ **An original adaptation of a musical work is also entitled to copyright**
- ✓ **There is no copyright in a song. A song has its words written by one man and its music by another; its words have a literary copyright, and so has its music. These two copyrights are entirely different and cannot be merged**
- ✓ **In cases where the word and music are written by the same person, or where they are owned by the same person, he would own the copyright in the song**



Examples of Musical work

In case of literary, dramatic or musical work, A copyright gives the right to do and authorize the doing of any of the following acts, namely

- **to reproduce the work in any material form;**
- **to publish the work;**
- **to perform the work in public;**
- **to produce, reproduce, perform or publish any translation of the work;**
- **to make any cinematographic film or a record in respect of work;**
- **to communicate the work by broadcast or to communicate to the public by loud-speaker or any other similar instrument for the broadcast of the work;**
- **to make any adaptation of work**



Artistic work

- ✓ **A painting**
- ✓ **A Sculpture**
- ✓ **A drawing including a diagram, map, chart or plan**
- ✓ **An engraving or a photograph, whether or not any such work possesses artistic quality**
- ✓ **“Work of architecture” - any building or structure having an artistic character or design, or any model for such building or structure**
- ✓ **A poster used in advertisement is an artistic work. But advertisement slogans consisting of a few words only are not copyright matter**

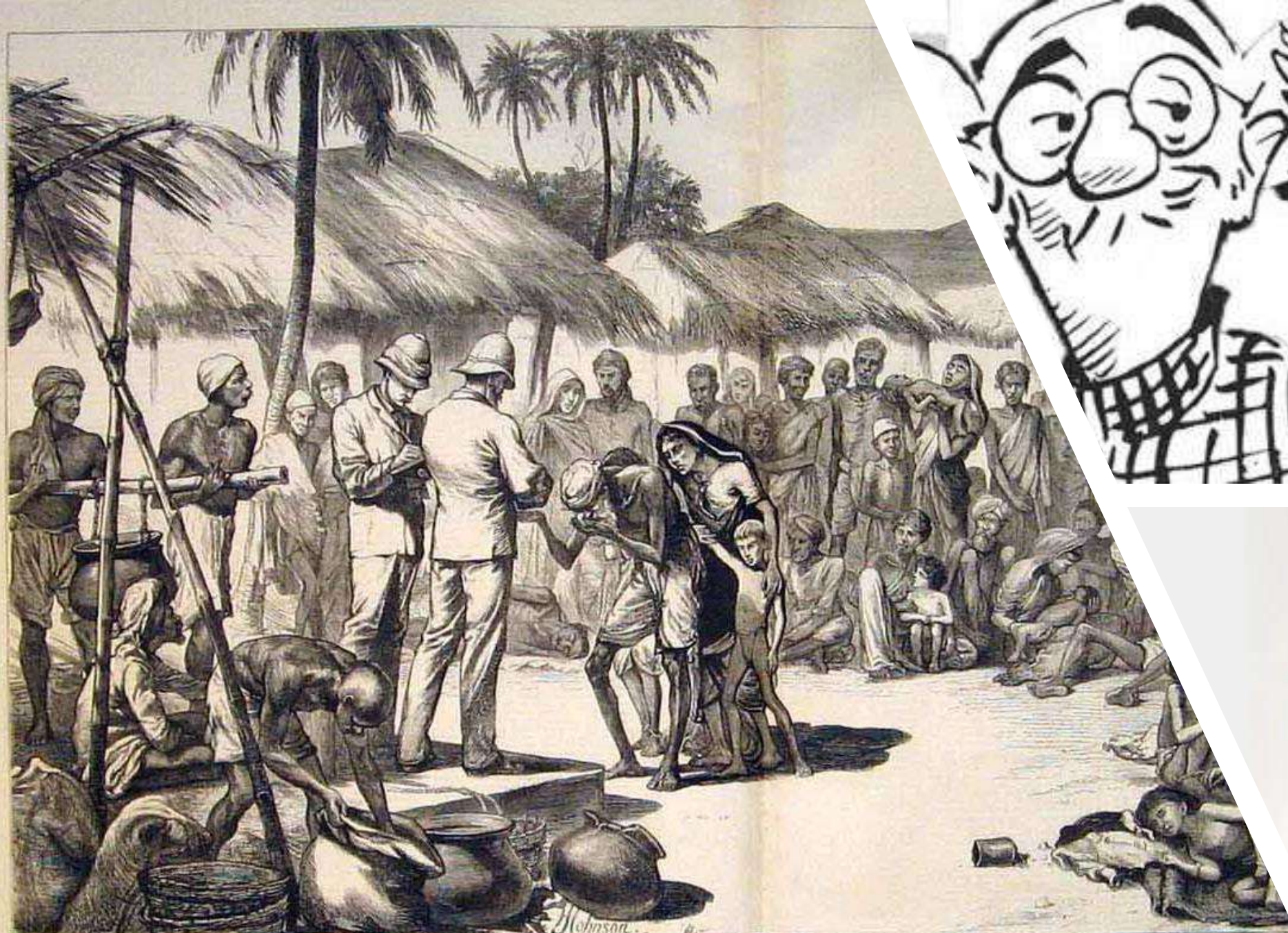

THE FAMINE IN INDIA - DISTRIBUTION BY THE OFFICIALS OF THE GOVERNMENT OF INDIA. COURTESY OF THE NATIONAL ARCHIVES, NEW DELHI. ILLUSTRATION BY JOHNSON.

Examples of Artistic work

In the case of the artistic work, a copyright gives the right to do or authorize the doing of any of the following acts, namely

- **to reproduce the work in any material form;**
- **to publish the work;**
- **to include the work in any cinematography film;**
- **to make any adaptation of work;**
- **to do in relation to an adaptation of the work**



Cinematographic work

- ✓ **Cinematograph film includes sound track, if any**
- ✓ **It includes any work produced by any process analogous to cinematography**
- ✓ **A video film is considered to be a work produced by a process analogous to cinematography**
- ✓ **A movie may be taken of a live performance like sport events, dramatic or musical performance**

Mandatory sharing act for sports of national importance



Examples (Cinematographic work)

In the case of cinematography film, copyright means the right to do or authorize the doing of any of the following acts, namely

- **to make copy of the film**
- **to cause the film, in so far as it consists of visual images, to be seen in public and, in so far as it consists of sounds, to be heard in public**
- **to make any record embodying the recording in the part of the sound track associated with the film by utilizing such sound track**
- **to communicate the film by broadcast**

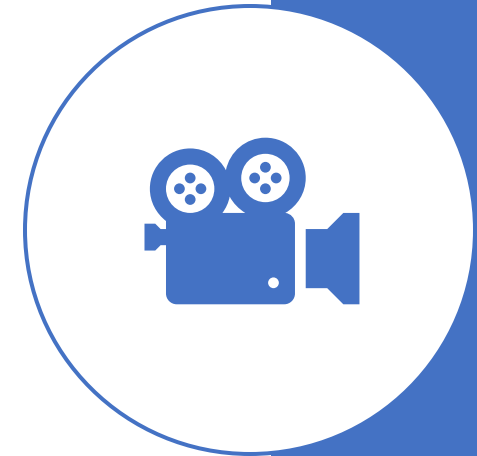

Records

- ✓ **Any disc, tape, perforated roll or other device in which sounds are embodied so as to be capable of being reproduced there from**
- ✓ **The sound track in a cinematography film is not a record unless it is separately recorded in a disc tape or other device**
- ✓ **Where the record is made directly from a live performance the owner of the disc or tape in which the recording is made will be the owner of the copyright**

Examples (Records)



In the case of a record, copyright gives the right to do or authorize the doing of any of the following acts by utilizing the record, namely-

- **to make any other record embodying the same recording;**
- **to cause the recording embodied in the record to be heard in the public;**
- **to communicate the recording embodied in the record by broadcast;**



Registration Procedure

- ✓ **Application for registration is to be made on Form XIV (Including Statement of Particulars and Statement of Further Particulars) as prescribed in the first schedule to the Rules**
- ✓ **Separate applications should be made for registration of each work**
- ✓ **Each application should be signed by the applicant and accompanied by the requisite fee is to be paid either in the form of Demand Draft or Indian Postal Order favouring "Registrar of Copyrights Payable at New Delhi" or through E payment**

Copyright Process

FLING OF
APPLICATION



01

02

ISSUE OF DIARY No.

30 days mandatory
Waiting for objections

03

04

Objection filed

Registrar decides to
accept/reject objections
Based on Hearing

05

06

Scrutinization by Examiner

Discrepancy letter
issued to applicant
(Reply within 45 days
of receipt of letter)

07

08

Hearing by Registrar

Registration approved

09



10

Sending Extracts from
Register to the Applicant

Term of Protection of Copyright



Literary, Dramatic, Musical or Artistic Works

Lifetime of the author and until 60 years from the death of the author



Anonymous & Pseudonymous Works

60 years from the year the work was first published



Works of Public Undertakings & Government Works

60 years from the year the work was first published



Works of International Organizations

60 years from the year the work was first published

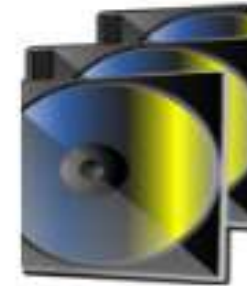

Sound Recording

60 years from the year in which the recording was published



Cinematograph Films

60 years from the year in which the film was published

Ownership of Copyright

- ✓ **The owner of copyright in a work is generally, at least in the first instance, the person who created the work, i.e. the author of the work**



- ✓ **But in some national laws , when a work is created by an author who is employed for the purpose of creating that work, and then the employer, not the author, is the owner of the copyright in the work**

Copyright protection

Economic rights

Allow right owners to derive financial reward from the use of their works by others

Copyright protection

Moral rights

Allow authors and creators to take certain actions to preserve and protect their link with their work

Assignment

- ✓ **Under an assignment, the rights owner transfers the right to authorize or prohibit certain acts covered by one, several, or all rights under copyright**
- ✓ **An assignment is a transfer of a property right. So, if all rights are assigned, the person to whom the rights were assigned becomes the new owner of copyright**



Licence

1

Licensing means that the owner of the copyright retains ownership but authorizes a third party to carry out certain acts covered by their economic rights, generally for a specific period of time and for a specific purpose.

2

For example, the author of a novel may grant a license to a publisher to make and distribute copies of his work. At the same time, he may grant a license to a film producer to make a film based on the novel.

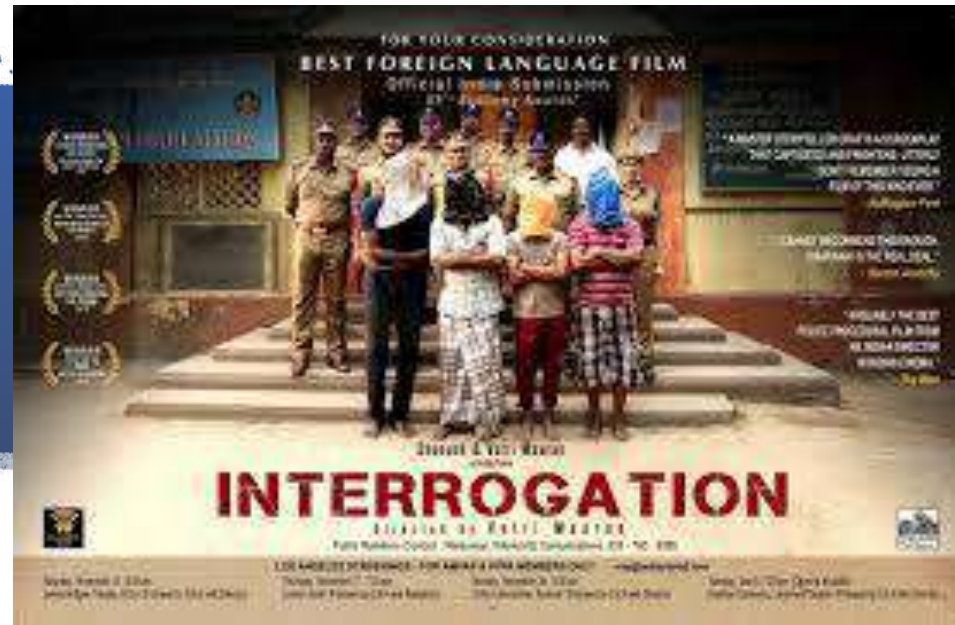
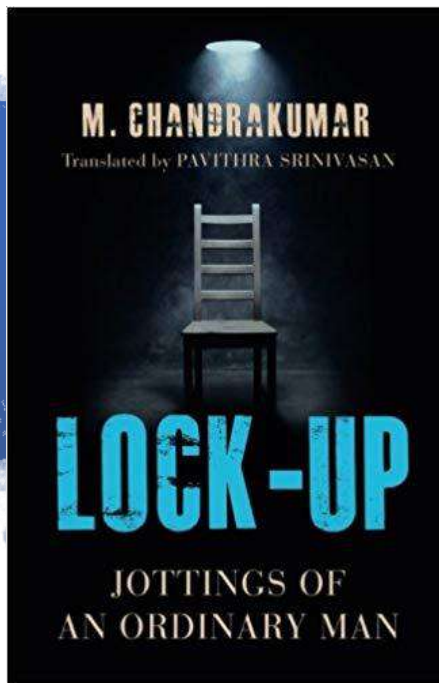

- ✓ Licenses may be exclusive, where the copyright owner agrees not to authorize any other party to carry out the licensed acts; or
- ✓ Non-exclusive, which means that the copyright owner may authorize others to carry out the same acts

Licensing may also take the form of Collective administration of rights

Under Collective administration, authors and other rights owners grant exclusive licenses to a single entity, which acts on their behalf to grant authorizations, to collect and distribute remuneration, to prevent and detect infringement of rights, and to seek remedies for infringement

An advantage for authors in collective administration lies in the fact that, with multiple possibilities for unauthorized use of works resulting from new technologies, a single body can ensure that mass uses take place on the basis of authorizations which are easily obtainable from a central source



A rights owner may also abandon the exercise of the rights, wholly or partially. The owner may, for example, post copyright protected material on the Internet and leave it free for anybody to use or may restrict the abandonment to noncommercial use.



Some very impressive cooperation projects have been organized on a model where contributors abandon certain rights as described in the licensing terms adopted for the project, such as the General Public License (GPL). They thereby leave their contributions free for others to use and to adapt, but with the condition that the subsequent users also adhere to the terms of the license.



Attribution

Others may distribute, remix, tweak, and build upon your work, even commercially, as long as they credit you for the original creation.



Attribution Share Alike

Others may remix, tweak, and build upon your work even for commercial reasons, as long as they credit you and license their new creations under the identical terms.



Attribution No Derivatives

Others may redistribute your work, commercially and non-commercially, as long as it is passed along unchanged, unedited, and attributed.



Attribution Non-Commercial

Others may remix, tweak, and build upon your work non-commercially, as long as they credit you.



Attribution Non-Commercial Share Alike

Others may remix, tweak, and build upon your work non-commercially, as long as they credit you and license their new creations under the identical terms. New work based on yours will carry the same license.



Attribution Non-Commercial No Derivatives

Others may share your work unedited and non-commercially as long as they credit you. (This is the most restrictive of the six licenses.)

EXAMPLE

Distributed under Creative Commons Attribution-ShareAlike - CC BY-SA.



Why Creative Commons?

Copyright Infringement



- ✓ **Copyright infringement occurs when someone other than the copyright holder copies the expression of a work**
- ✓ **When any person, without a license granted by the owner of the Copyright or the Registrar of Copyrights under the Act or in contravention of the conditions of a license so granted or of any condition imposed by a competent authority**
- ✓ **The reproduction of a literary, dramatic, musical or artistic work in the form of a cinematograph film shall be deemed to be an "infringing copy"**

Rights of the Copyright owner



The Right to Reproduce the Work: This is the right to reproduce, copy, duplicate or transcribe the work in any fixed form. Copyright infringement would occur if someone other than the copyright owner made a copy of the work and resold it.



The Right to Derivative Works: This is the right to modify the work to create a new work. A new work that is based upon an existing work is a "derivative work." Copyright infringement would occur here if someone releases or remixes of one of your songs without your consent.



The Right to Distribution: This is simply the right to distribute the work to the public by sale, rental, lease or lending. The music industry lawsuits targeting file-sharing web services claim that these services violate the right to distribution held by record labels.

Rights of the Copyright owner



The Public Display Right: This is the right to show a copy of the work directly to the public by hanging up a copy of the work in a public place, displaying it on a website, putting it on film or transmitting it to the public in any other way. Copyright infringement occurs here if the someone other than the copyright holder offers a work for public display



The Public Performance Right: This is the right to recite, play, dance, act or show the work at a public place or to transmit it to the public. Copyright infringement would occur here if someone decided to give performances of the musical without obtaining permission from the owner

Exceptions



For the purpose of research or private study



For criticism or review



For reporting current events



In connection with judicial proceeding



Performance by an amateur club or society if the performance is given to a non-paying audience



The making of sound recordings of literary, dramatic or musical works under certain conditions

Remedies



Civil

Injunction Damages or account of profit, delivery of infringing copy and damages for conversion.



Criminal

Imprisonment of the accused or imposition of fine or both



Administrative

Moving the Registrar of copyrights to ban the import of infringing copies into India

Cinematograph Amendment Bill, 2019



For Piracy

Imprisonment up to
3 years
+
Fine upto 10 lakhs

Related Rights

- ✓ **Related rights (also known as neighboring rights) are rights of performers, producers of sound recordings and broadcasting organizations.**
- ✓ **These related rights are secondary rights and cannot exist on their own, but they accrue from the copyrighted work.**
- ✓ **These are the rights given to the persons or legal entities who contribute to producing or making of the copyrighted work.**



Rights of performers

- Their creative intervention is necessary to give life to, for example, motion pictures or musical, dramatic and choreographic works

Rights of producers of sound recordings

- Their creative, financial and organizational resources are necessary to make sound recordings, often based on musical works, available to the public in commercial form



Rights of broadcasting organizations

- Their role in making works available to the public



D/B Copyrights and Related Rights



"Copyright" in its narrow sense usually refers to the rights of authors in their literary and artistic works



In the wider sense, copyright also includes "related rights"

D/B Copyrights and Related Rights



Protection of copyright is to encourage and reward creative work and it is the economic backbone of cultural industries



Protection of related rights is to protect the Performers for their creative work and it safeguards the investments of the producing organizations

Links for Reference

World Intellectual Property Organisation

<https://www.wipo.int/copyright/en/>

Copyright Office

<http://copyright.gov.in/>

Cell for IPR promotion and Management (CIPAM)

<http://cipam.gov.in/know-your-ip-2/copyrights/>

To know more...

Visit : <http://www.bdu.ac.in/cells/ipr/>

E-Books on IPR :

<http://www.bdu.ac.in/cells/ipr/docs/ipr-tamil-ebook.pdf> (Tamil)

<http://www.bdu.ac.in/cells/ipr/docs/ipr-eng-ebook.pdf> (English)

E-mail: iprcell@bdu.ac.in

Thanks for your Participation



Value added course **Intellectual Property Rights**

Chapter - 4

What we are going to discuss

Trademark - Introduction

Different kinds of marks

Non Registrable Trademarks

Registration of Trademarks

Rights of holder

Assignment and licensing of marks

Infringement, Remedies & Penalties

Trademarks registry and appellate board



Trademark - Introduction

- ✓ **A trademark is a mark which is unique, distinctive, made up of names, symbols, signs etc., and capable of distinguishing one product from another used by manufacturer or vendor in connection with a product or service**
- ✓ **Term of protection of a trademark is ten years, which may be renewed for a further period of ten years on payment of prescribed renewal fees**

Examples

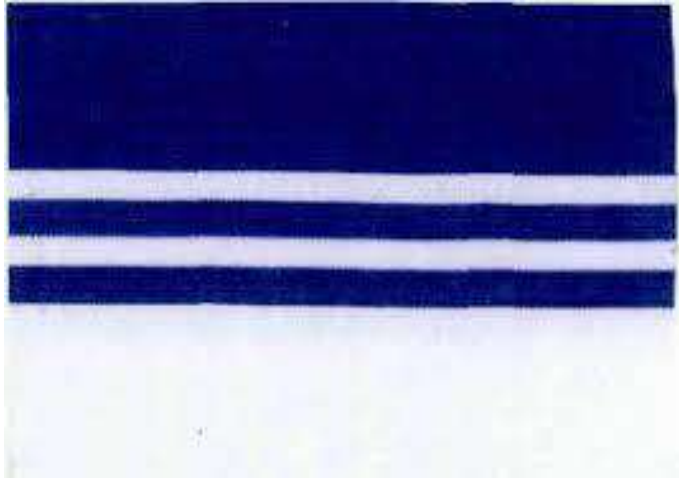

Development of Trademark law in India

India's statutory Trademarks Law



1860

1940

Indian Trademarks Act in corresponded
with the English Trademarks Act

Trademark and Merchandise Act

1958



1999

Trademark Act

Amendment : 2010

Different kinds of marks



SERVICE MARK



COLLECTIVE
MARK



CERTIFICATION
MARK

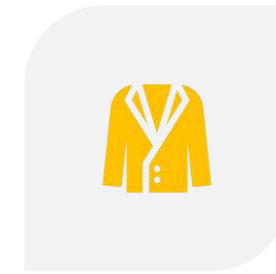

TRADE DRESS

Service Mark

A service Mark is any word, name, symbol, device, or any combination used or intended to be used in commerce to identify and distinguish the services of one provider by others and to indicate the source of services

Service Marks do not cover physical goods but only the provision of services

It plays a crucial role in referring to a particular quality or standard for which the service mark is used and for marketing, promoting and sales of a product or service

Examples for Service Mark

campuslogicSM

FedEx



 graniteSM
Trademark Services

UNITED AIRLINES 

Collective Mark

A collective Mark is one used by members of a cooperative association, union or other collective group or other group or organization to identify source of the goods or services.

1. Collective Membership Mark: These marks are not used to indicate source of goods or services, but they indicate that the seller is part of a defined group

2. Collective Trademarks and Collective Service marks: These are used to indicate the source. Such collective marks are used by a group to indicate that the goods or services offered by each individual member of the group are products or services of the collective

Examples for Collective Mark

RELIANCE
Anil Dhirubhai Ambani Group



CAMBRIDGE
UNIVERSITY PRESS

Certification Mark

A certification Mark is a mark which indicates that certain qualities of goods or services in connection with which the mark are used is certified.

An important requirement for registration of certification mark is that entity which applies for registration is competent to certify the products concerned

Thus, owner of certification mark must be representative of products to which certification mark applies

Examples for Certification Mark

CE



Handloom

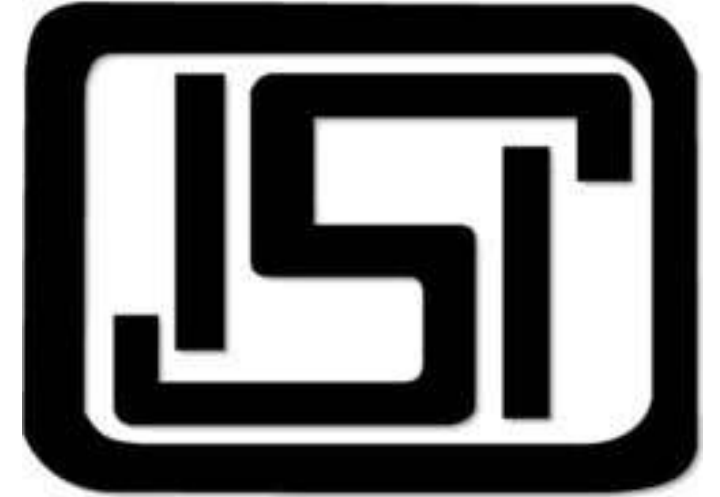

WOOLMARK



Trade Dress

Trade dress refers to combination of elements that make up the look, feel, or environment of a product or business; the term can refer to individual elements of a product or business image as well as to the image the combination of those elements creates as a whole

Trade Dress may include a few important features like Packaging, Size, Shape, Colour, Colour Combination, Texture, Graphics Design, Placement of words and decorations on a product and Particular Sale Technique

Examples for Trade dress



Non-registerable Trademarks



It is of such nature as to deceive the public or cause confusion



It contains or comprises of any matter likely to hurt the religious susceptibilities of any class of section of the citizens of India



It comprises or contains scandalous or obscene matter



Its use is prohibited under the Emblems and Names (Prevention of Improper Use) Act, 1950 (12 of 1950).

Non-registerable Trademarks



EXCLUSIVELY OF THE SHAPE OF GOODS
WHICH RESULTS FROM THE NATURE OF
THE GOODS THEMSELVES



THE SHAPE OF GOOD WHICH IS NECESSARY
TO OBTAIN A TECHNICAL RESULT



THE SHAPE WHICH GIVES SUBSTANTIAL
VALUE OF THE GOODS

Procedure for registration of Trademark

Any person claiming to be the proprietor of a trade mark used or proposed to be used, who is desirous of registering it, shall apply in writing to the Registrar in the prescribed manner for the registration of trade mark

A single application may be made for registration of a trade mark for different classes of goods and services and fee payable therefore shall be in respect of each such class of goods or services

Every application shall be filed in the office of the Trade Mark Registry within whose territorial limits the principal place of business in India

Trademark Registration Process

Registration of a trade mark could be completed within twelve months from the date of application

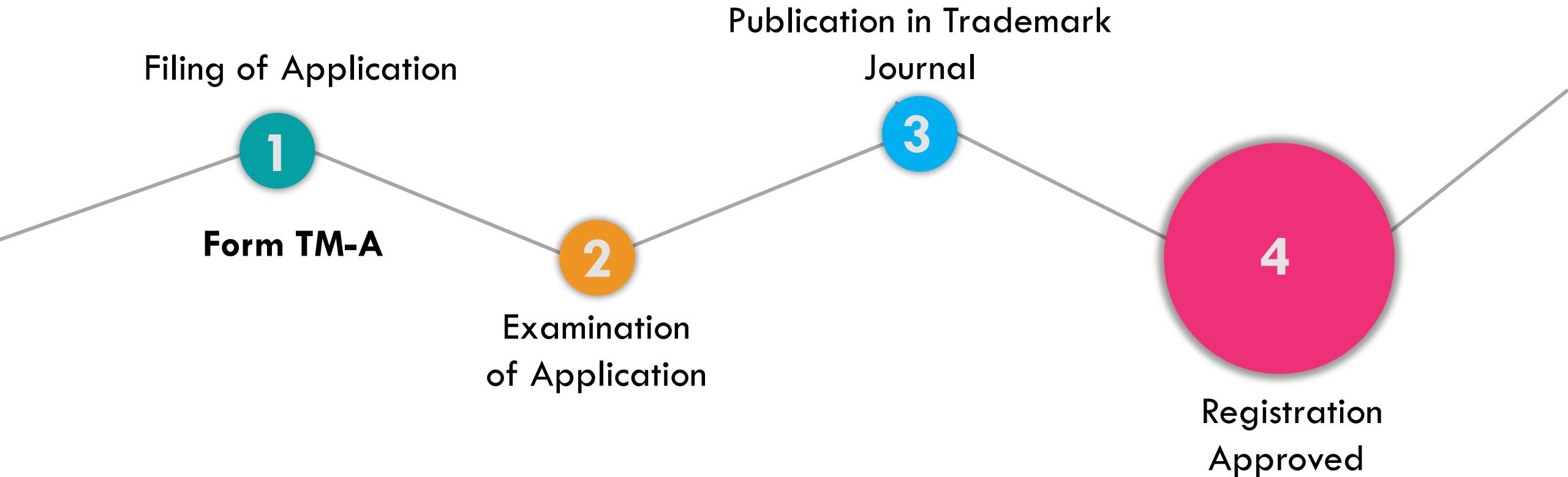



Madrid Protocol

The Protocol allows you to obtain and maintain protection for your brand around the world

Single Filing to seek protection in various Territories

Centralized Management of your Trade Marks

Registration of Trademarks - International

File International Application form (MM2) through online



- **National of India**
- **Natural person or legal entity domiciled in India**
- **“Basic mark” in India**

Check

- **The applicant details**
- **Mark in application is identical to basic mark**
- **Goods and services are covered by those basic mark**

Certification by India TM Registry

Transmission of International Application

Amount of fee in Swiss Francs pay directly to WIPO

Publish the international registration in the WIPO Gazette of International Marks

Notify it to the Offices of the designated Contracting Parties (DCPs)



International Trademark Registration

ISSUE OF INTERNATIONAL REGISTRATION CERTIFICATE

Assignment of Trademarks

Assignment is the transfer of ownership which simply means any act of parties by which interest or rights associated with property of any kind can be transferred from one party to another party

The assignee will become the subsequent proprietor of the trademark assigned whether in part or in full based on the conditions agreed between the parties

Trade mark can be assignable or transmissible by three Modes

- **By legal operation**
- **Inheritance**
- **Giving authority to other party**

Transfer of Trademark along with goodwill

All the rights vested in trademark with rights to use, sell, assign, transfer, modify, delete or stop such or any kind of products or services in respect of that trademark are completely transferred to assignee with no reservation



Transfer of Trademark without goodwill

Assignor has reserved their rights in respect of such trademark in particular goods or services & has not absolutely transferred the trademark in all goods or services. This means that assignor & assignee both can use the same trademark but in dissimilar goods or services



License of Trademarks

The licensee of a trademark will enjoy the same rights as that enjoyed by a registered trademark proprietor.

Thus, the benefit of use of the mark by an unregistered user also accrues to the registered proprietor



NOKIA

Franchise of Trademarks

Right to sell goods/services supplied by seller with the usage of trademark and also franchiser teaches entire business format



Trademark Infringement

A registered trade mark is infringed by a person who, not being a registered proprietor or a person using by way of permitted use, uses in the course of trade

- **which is identical with, or deceptively similar to, the trade mark in relation to goods or services in respect of which the trade mark is registered**
- **cause confusion on the part of the public**
- **use as their trade name or part of their trade name, or name is their business concern or part of the name, of their business concern dealing in goods or services**
- **used for labeling or packaging goods, as a business paper, or for advertising goods or services**

Examples



Mars' MALTESERS



Hershey's MALTESER

Remedies



1. Interim Injunctions - During the pendency of the case before a full-fledged trial
2. Permanent Injunctions - Full-fledged trial



Penalties

The penalty that a court may grant in any suit for infringement for applying false trademarks, trade descriptions includes an injunction and at the option of Plaintiff, either damages or an account of profits

Enhanced penalty on second or subsequent conviction

- Imprisonment for a term of one year may extend to 3 years**
- Fine of one lakh rupees may extend to two lakh rupees**



Trademark Registry contains Names, addresses and description of the proprietors, notifications of assignment and transmissions, the name, addresses and description of registered users, conditions, limitations and such other matters relating to registered trade mark



There shall be kept at each branch office of the Trade Marks Registry



The Register shall be kept under the control and management of the Registrar

Registrar of Trademark and Trademark Registry

Intellectual Property Appellate Board (15th September 2003)



The Appellate Board shall consist of a Chairman, Vice –Chairman and such number of other Members, as the Central Government may, deem fit and the jurisdiction, powers and authority of the Appellate Board may be exercised by Benches



A bench shall consist of one Judicial Member and one Technical Member and shall sit at such place as the Central Government may, by notification in the Official Gazette

Links for Reference

World Intellectual Property Organisation

<https://www.wipo.int/trademarks/en/>

Controller General of Patents, Designs and Trademarks

<http://www.ipindia.nic.in/trade-marks.htm>

Cell for IPR promotion and Management (CIPAM)

<http://cipam.gov.in/know-your-ip-2/trademark/>

To know more...

Visit : <http://www.bdu.ac.in/cells/ipr/>

E-Books on IPR :

<http://www.bdu.ac.in/cells/ipr/docs/ipr-tamil-ebook.pdf> (Tamil)

<http://www.bdu.ac.in/cells/ipr/docs/ipr-eng-ebook.pdf> (English)

E-mail: iprcell@bdu.ac.in

Thanks for your Participation





THE ENFORCEMENT OF INTELLECTUAL PROPERTY RIGHTS:

A CASE BOOK

LTC Harms

3rd Edition – 2012



TABLE OF CONTENTS

PREFACE		p. 5
ACKNOWLEDGEMENTS		p. 7
CHAPTER 1	INTRODUCTION	p. 9
CHAPTER 2	TRADEMARKS: GENERAL PRINCIPLES	p. 41
CHAPTER 3	TRADEMARKS: INFRINGEMENT	p. 79
CHAPTER 4	TRADEMARKS: CONFUSION	p. 107
CHAPTER 5	TRADEMARKS: WELL-KNOWN TRADEMARKS	p. 137
CHAPTER 6	TRADEMARKS: DEFENSES	p. 157
CHAPTER 7	COPYRIGHT: INTRODUCTION	p. 165
CHAPTER 8	COPYRIGHT: SUBSISTENCE OF COPYRIGHT	p. 191
CHAPTER 9	COPYRIGHT: INFRINGEMENT	p. 213
CHAPTER 10	COPYRIGHT: DEFENSES	p. 231
CHAPTER 11	PATENTS: GENERAL PRINCIPLES	p. 243
CHAPTER 12	PATENTS: INTERPRETATION	p. 267
CHAPTER 13	INDUSTRIAL DESIGNS	p. 309
CHAPTER 14	UNFAIR COMPETITION: INTRODUCTION	p. 327

CHAPTER 15	UNFAIR COMPETITION: PASSING OFF	p. 337
CHAPTER 16	UNFAIR COMPETITION: CONFIDENTIAL INFORMATION	p. 365
CHAPTER 17	EXHAUSTION OF IP RIGHTS	p. 373
CHAPTER 18	PROVISIONAL REMEDIES	p. 395
CHAPTER 19	INJUNCTIONS (INTERDICTS)	p. 423
CHAPTER 20	DAMAGES	p. 433
CHAPTER 21	CRIMINAL ENFORCEMENT OF IP RIGHTS	p. 463
CHAPTER 22	COUNTERFEITING OF TRADEMARK GOODS	p. 497
CHAPTER 23	PIRACY OF COPYRIGHT GOODS	p. 521
CHAPTER 24	SENTENCING	p. 533
CHAPTER 25	BORDER MEASURES, TRANSIT AND TRANSHIPMENT	p. 547
CHAPTER 26	DISPOSAL OR DESTRUCTION OF INFRINGEMENT AND COUNTERFEIT GOODS	p. 565

¹The views expressed in this work are those of the author in his personal capacity and do not necessarily represent the positions or opinions of the Member States or the Secretariat of the World Intellectual Property Organization".



Intellectual property (IP) violations remain a global concern. This is reflected, *inter alia*, in a constant high demand for IP enforcement-related technical assistance addressed to WIPO by its Member States. Within the mandate of the Advisory Committee on Enforcement (ACE), WIPO services include legislative advice, specialized training as well as educational and awareness programs, seeking to assist Member States in further developing effective and balanced IP enforcement systems, in the interest of socio-economic development and consumer protection.

In this context, Member States continuously emphasize the need for improved access to case law developments relating to IP enforcement. In response to this demand, the Honorable Justice Harms, former Deputy President of the Supreme Court of Appeal of South Africa and renowned international expert in the field, was asked to prepare the WIPO Case Book on the Enforcement of IP Rights; the first edition focusing on common law jurisdictions, and the second covering both common and civil-law jurisdictions.

The Case Book proved to be popular and an excellent training tool for the judiciary, law enforcement officials, attorneys and right holders. Building on this success, WIPO has requested Mr. Justice Harms to update and further develop this important publication.

The present work is the third edition thereof.

WIPO is grateful to Mr. Justice Harms for preparing this new edition. It is a compilation of IP enforcement-related case law from a great number of courts and tribunals, providing an in depth analysis of common and civil-law jurisprudence, underscoring similarities and, where appropriate, highlighting differences. It covers the most recent decisions on topical issues in common and civil-law jurisdictions (including the case-law of the Court of Justice of the European Union).

I am convinced that this third edition, like the first two editions, will constitute a relevant tool to further enhance the handling of IP cases in developing countries and to enhance confidence in the IP system.



Francis Gurry
Director General
World Intellectual Property Organization



“Ignorance has many virtues, amongst them the fact that it tends to produce a feeling of self-confidence which allows one to contemplate large projects with a sense of complete equanimity.”¹

These words are apposite to this third edition of a case book which, in its first edition, sought to give an overview of the enforcement aspects of intellectual property law in the common-law and mixed law systems; but the second and third editions seek to give the reader some insight into civil-law principles and jurisprudence – in spite of my limited expertise.

In preparing the case book I was again reminded of Sisyphus: he who was condemned by the gods to push a rock up a mountain, eternally. Whenever he reaches the top, the rock rolls down again. On each occasion when the end was supposed to be near another statute or judgment would surface, some new and some old. And I had and still have the uncomfortable realization that much of value must have been missed in the process of trawling with a net with a large gauge through books, law reports and the Internet. In Paul Theroux’s imagery, preparing a case book on IP enforcement is like a two-pound chicken trying to lay a three-pound egg. As is the case with any collection, the choice depends on whatever the selector knows of or can find with relative ease and is comfortable with, which explains (but not justifies) the fact that I have sometimes resorted to picking myself up by my own shoestrings by quoting my own judgments.

The *causa causans* of this work was the request from the World Intellectual Property Organization (WIPO) and especially the active support and encouragement of members of its Building Respect for IP Division, whose confidence in my abilities must have been sorely tested during the course of the project. I thank them.

The *conditio sine causa* is, however, my mentor, the late Dr JR Steyn, who introduced me to this field of the law in 1967, and tried to keep me on course for more than 20 years. His memory I wish to honor.

Contributory *causae* are especially my wife, Irene, who believed that the book could become a reality and my family, and colleagues and counsel with whom I have debated many of the issues that are reflected in the notes.

In the preface to the first edition I thanked Mr. Pravin Anand, who provided me with a summary of the ‘best IP cases’ and other material from India, and Mr. Robert L Baechtold, who gave me a number of useful US references. I also expressed my appreciation to those who had read and commented

1 Charles van Onselen *New Babylon New Nineveh* (preface to the first edition) 2001.

on the whole or part of the original manuscript in its different stages: Professor David Vaver, Advocate L Bowman SC, and the staff members of WIPO involved.

For this edition I have to add to the list two names who require special mention. The first is Ms. Anja Petersen of the firm Hoffmann Eitle, Munich, who provided me with a collection of German case law and assisted me in understanding some German legal concepts. The second is Mr. Tetsuo Niwa (the former director of the Asia-Pacific Industrial Property Center at the Japan Institute of Invention and Innovation). The Center has an exceptionally useful series of case books on Intellectual Property Rights, which were kindly provided for my use with the consent of the Japan Patent Office.

Errors and omissions, however, remain my responsibility, and the views expressed are not those of WIPO but my own.

A handwritten signature in black ink, appearing to read 'Louis Harms', with a stylized flourish at the end.

Louis Harms
Supreme Court of Appeal
South Africa

INTRODUCTION

CHAPTER I

- A. THE SCOPE OF THIS BOOK (1-6)
- B. WHAT IS INTELLECTUAL PROPERTY? (7-13)
- C. NATIONAL AND INTERNATIONAL LAW (14-16)
- D. THE TRIPS AGREEMENT (17-21)
- E. REGISTERED AND UNREGISTERED RIGHTS (22)
- F. CIVIL AND CRIMINAL LAW (23)
- G. IP RIGHTS AS BASIC HUMAN RIGHTS (24-26)
- H. THE JUSTIFICATION FOR THE RECOGNITION AND ENFORCEMENT OF IP RIGHTS (27-36)
- I. JURISDICTION (37-41)
- J. THE EDITORIAL POLICY (42-46)
- K. USEFUL WEBSITES (47)

A. THE SCOPE OF THIS BOOK

1. *Enforcement of IP rights:* This work was written at the request of the World Intellectual Property Organization (WIPO), more particularly the WIPO Building Respect for IP Division and its purposes. The Division's focus on enforcement has changed, as has its name. However, the main subject of this work remains the enforcement of intellectual property rights ("IP rights" or "IPRs"). It should be emphasized that the views expressed are those of the author and not of WIPO.

The work falls into three parts. The first section deals with the infringement of the most important IP rights; the second with civil remedies; and the final part, which is self-contained, deals with criminal enforcement, particularly counterfeiting and piracy and related procedural issues.

2. *Readership:* The work is intended for those who are involved in the enforcement of IP rights such as judicial officers in both civil and criminal courts, lawyers, prosecutors, as well as law enforcement officers and customs officials.

3. *Common law and civil-law:* The first edition of this work focused on legal systems with a common-law background, including those with a mixed civil and common-law system, and countries that use English as a court language.

The later editions attempt to expand the legal horizon and use judgments from civil-law jurisdictions as well as those from the European Court of Justice. However, the *droit romain* legal tradition is covered by another WIPO publication, namely that by Marie-Françoise Marais & Thibault Lachacinski *L'application des Droits de Propriété Intellectuelle* (2007) and this work does not purport to overlap with that work.

Since this is a "casebook" (or source book) and has to cover a large number of jurisdictions, the accessibility of judgments quoted is a major selection criterion. Consequently, most of the judgments and other material referred to are of fairly recent origin and can be found on the Internet. Extracts from older cases are generally those that are commonly quoted and can, therefore, be traced indirectly.

The differences between the substantive provisions of IP laws in common-law and civil-law countries are relatively small. The laws are all very similar in content and the result in any particular IP case, on the same evidence, ought to be the same whatever the legal system.

HARVARD COLLEGE v CANADA (COMMISSIONER OF PATENTS)

2002 SCC 76 [Canada]

Intellectual property has global mobility, and states have worked diligently to harmonize their patent, copyright and trademark regimes. Intellectual property was the subject matter of such influential agreements as the *International Convention for the Protection of Industrial Property (Paris Convention)* as early as 1883. International rules governing patents were strengthened by the *European Patent Convention* in 1973, and, more recently, the *World Trade Organization Agreement on Trade-Related Aspects of Intellectual Property Rights (TRIPS)* in 1994. Copyright was the subject of the *Berne Convention for the Protection of Literary and Artistic Works* in 1886, revised by the *Berlin Convention* of 1908 and the *Rome Convention* of 1928. The *Universal Copyright Convention* was concluded in 1952. Legislation varies of course, from state to state, but broadly speaking Canada has sought to harmonize its concepts of intellectual property with other like-minded jurisdictions.

The mobility of capital and technology makes it desirable that comparable jurisdictions with comparable intellectual property legislation arrive (to the extent permitted by the specifics of their own laws) at similar legal results.

The differences between the two systems are, in the present context, firstly procedural. The common-law judge plays a less active role in the proceedings than the civil-law judge because in the case of the former the parties drive the litigation. Judges in common-law countries at first instance (and on appeal) are seldom specialists in the particular field of litigation and as a general rule do not sit with experts or use court experts.

The eminent social philosopher, Max Weber, stated the difference in these terms: he classified the civil approach as logically rational, based on generic rules (a jurisprudence of concepts) while the common-law method of thought is based on reasoning by example. This means that civil-law courts tend to concentrate on identifying principles (German: *das Prinzip*) while common law courts tend to be more pragmatic. There is also the emphasis in the civil systems of the *droit moral* (IP law has a moral aspect); the civil definition of a tort or delict is open-ended; and, depending on the court's understanding of the commercial morals of society, outcomes may differ from case to case.

The common law lays greater emphasis on the value and binding force of precedents than does the civil-law and, consequently, judgments in common-law countries tend to be more wide-ranging than in civil-law countries. As

Sir Stephen Sedley (a judge from England) wrote,¹ “the prose form of common-law judgments remains that of the oral judgment, and the oral judgment at base represents the process of thinking aloud. Civil-law judgments are more closely reasoned and somewhat formalistic in the sense that they are not self-explanatory and are therefore not as elaborate and loquacious as common-law judgments, which tend to restate the law in terms broader than required by the specific case. Appellate judgments in the civil tradition usually answer legal questions put to that court (a “cour de cassation”) and refer the case back for finalization to the lower court while such judgments in the common-law tradition may raise new legal issues and may involve a reconsideration of the factual underlay and usually lead to the final disposal of the case without a reference back. Dissenting or concurring judgments are also not widespread in the civil tradition.”

Dieter Stauder explained:

“The German style of judgment is, at least according to textbooks and arguably is in practice also, an expression of the authority of judges. It represents the outcome from the judge’s point of view: not in a discursive, but rather an authoritative way. Quite apart from anything else, there is the strangeness of German law that the names of the judges, of the parties and of other persons involved are left out of published judgments.

On the other hand, the English judgment is exemplary in style. The judge writes personally, he sets out the matter in concrete and detailed manner, he explains what he thinks, opines, has reservations and doubts, is irritated. The English judgment is discursive, in some ways narrative, but nonetheless human.”²

These remarks, which are applicable not only to German and English judgments, explain in part the limited use of civil-law precedents in this work.

4. Generalizations: This comparative exercise contains by its very nature many generalizations because it is basic and the degree of exposure to IP law by those who may have occasion to use it may vary considerably.

The work is also incomplete especially because information about the enforcement of IP laws in developing countries, to the extent it exists, is not freely available. Although IP litigation is more prevalent in developed countries, language barriers are a limiting factor and prevent the use of a broader selection of jurisprudence.

1 “Second Time Around” *London Review of Books* September 6, 2007.

2 Dieter Stauder (with David Llewelyn) “Oskar Hartweg’s thoughts on the English legal system” in David Vaver and Lionel Bently *Intellectual Property in the New Millennium - Essays in Honour of William R. Cornish* (2004) p. 56.

5. *Differences*: Within each legal tradition laws differ from jurisdiction to jurisdiction; and every individual system of law has its own history and development, which accords with its own legal culture, statutes and judge-made law. It would consequently be wrong to assume that there is a unified or single common-law or civil-law IP law system. It is also dangerous to assume that IP law and practice of different jurisdictions always (or necessarily) correspond. Although the laws of the different countries may bear substantial similarity, the differences between any two legal systems may result in different outcomes in any particular case on the same facts.

BEECHAM GROUP PLC v TRIOMED (PTY) LTD

[2002] ZASCA 109 [South Africa]

The learned judge [in the trial court] relied heavily upon the [UK] judgment of Aldous LJ in *Philips Electronics NV v Remington Consumer Products Ltd* [and the judgment of] the European Court of Justice in *Koninklijke Philips Electronics NV v Remington Consumer Products Ltd*. These judgments all have persuasive force because s 10 of the [South African Trade Marks] Act is based upon the First Council Directive 89/1988 of the Council of the European Communities “(t)o approximate the laws of the Member States relating to trade marks”. The British Trade Marks Act had to conform to the Directive and its interpretation by the ECJ binds the English Courts. This does not mean that we are bound to follow these authorities. The Act remains a South African statute, which must be interpreted and applied in the light of our law and circumstances. Local policy considerations may differ from those applicable in Europe. The application of rules remains, even in Europe, a matter for local courts and they differ occasionally amongst themselves.

HUMAN GENOME SCIENCES INC v ELI LILLY AND COMPANY

[2011] UKSC 51 (2 November 2011)

In a number of recent decisions of the House of Lords, attention has been drawn to “the importance of UK patent law aligning itself, so far as possible, with the jurisprudence of the EPO (and especially decisions of its Enlarged Boards of Appeal)”. It is encouraging that the same approach is being adopted in Germany by the Bundesgerichtshof.

However, as Lord Walker went on to explain in *Generics* [2009] RPC 13, par 35, “National courts may reach different conclusions as to the evaluation of the evidence in the light of the relevant principles” even though “the principles themselves should be the

same, stemming as they do from the EPC". Thus, the EPO (or another national court) and a national court may come to different conclusions because they have different evidence or arguments, or because they assess the same competing arguments and factual or expert evidence differently, or, particularly in a borderline case, because they form different judgments on the same view of the expert and factual evidence.

6. *UK and US law:* The modern jurisprudence in the United Kingdom which, until recently, has been a major source of information and inspiration for the judiciaries of the common-law world, is now becoming of a different value because UK law is "subject" to European Union law, and directives of the European Union are drawing the UK more and more into the civil-law camp. Conversely, the civil-law is being influenced by common-law principles.³

Another warning for those interested in comparative exercises concerns the law of the United States of America. It is heavily influenced by the fact that much of its IP law is derived from its Constitution and its federal nature (although not all trademark, unfair competition or all copyright issues are federal) and it differs in many respects from the laws of other common-law jurisdictions that had or have closer or more recent ties with the UK, such as Australia and Canada whose federal constitutions did not create a similar diversity.

B. WHAT IS INTELLECTUAL PROPERTY?

7. *Intangible property right:* Much has been written about the nature and meaning of IP rights but they can best be described as intangible property rights or rights in ideas. As a WIPO publication explained:⁴

"The history of the human race is a history of the application of imagination, or innovation and creativity, to an existing base of knowledge in order to solve problems. Imagination feeds progress in the arts as well as science. Intellectual property (IP) is the term that describes the ideas, inventions, technologies, artworks, music and literature, that are intangible when first created, but become valuable in tangible form as products. Suffice it to say that IP is the commercial application of imaginative thought to solving

³ See, for instance, Directive 2004/48/EC of the European Parliament and of the Council of 29 April 2004 on the enforcement of intellectual property rights, *OJ*, 2004, L195/16. There is little, if anything, in the Directive that does not accord with the procedural law of common-law countries.

⁴ *Intellectual Property: A Power Tool for Economic Growth*, (WIPO Publication No 888) p10-11.

technical or artistic challenge. It is not the product itself, but the special idea behind it, the way the idea is expressed, and the distinctive way it is named and described.

The word “property” is used to describe this value, because the term applies only to inventions, works and names for which a person or group of persons claim ownership. Ownership is important because experience has shown that potential economic gain provides a powerful incentive to innovate.”

COLBEAM PALMER LTD v STOCK AFFILIATES PTY LTD

(1968) 122 CLR 25 (HCA) [Australia]

Although the proposition may involve one’s conception of the nature of property, it can hardly be said that a registered trademark is not a species of property of the person whom the statute describes as its registered proprietor, and which it permits him to assign. Griffith CJ spoke of a trademark as

“the visible symbol of a particular kind of incorporeal or industrial property consisting in the right of a person engaged in trade to distinguish by a special mark goods in which he deals, or with which he has dealt, from the goods of other persons”.

8. *IP covers many unrelated areas:* The Stockholm Convention, which established the World Intellectual Property Organization, states that intellectual property includes the rights relating to:

- literary, artistic and scientific works,
- performances of performing artists, phonograms, and broadcasts,
- inventions in all fields of human endeavor, scientific discoveries,
- industrial designs,
- trademarks, service marks, and commercial names and designations,
- protection against unfair competition, and
- all other rights resulting from intellectual activity in the industrial, scientific, literary or artistic fields.

9. *Intellectual and industrial property:* The general use of the term “Intellectual Property Law” is, in English law at least, of fairly recent origin and has become acceptable in spite of some theoretical objections to it. Since it forms part of the name of WIPO it is here to stay.

The French equivalent *propriété intellectuelle* and also the Spanish *propiedad intelectual*, the German *geistiges Eigentum* and the Dutch *geestelijk (immateriële) eigendom* have the same meaning, implying intangible or immaterial (rather than physical) property that is the product of the intellect or of a mental process. These terms, however, are usually reserved for literary and artistic works, in other words, copyright and related rights.

The term “copyright” is somewhat of a misnomer even though it is commonly used in the common-law tradition. The correct term, which is used within the civil-law tradition, is author’s right. *The Berne Convention for the Protection of Literary and Artistic Works (1886)*, which deals with the subject, speaks of literary and artistic works and uses neither copyright nor author’s right. Instead it defines these works in general terms to include every production in the literary, scientific and artistic domain, whatever may be the mode or form of its expression” and then lists examples.

The term “industrial property”, derived from French law, covers (as indicated in *the Paris Convention for the Protection of Industrial Property (1883)*)⁵

“patents, utility models, industrial designs, trademarks, service marks, trade names, indications of source or appellations of origin, and the repression of unfair competition.”

Consequently, the term excludes copyright and related rights (i.e. rights relating to performances of performing artists, phonograms, and broadcasts). Underlying the distinction is the theory that copyright concerns artistic creations and is not dependent on formalities (such as registration) for its subsistence, whereas industrial property concerns creations that are essentially for industrial purposes, and the rights are dependent on compliance with prescribed formalities. Furthermore, the owner of copyright has a moral right in the creation whereas the owner of industrial property has no such right. The problem is that the supposition that copyright is concerned with artistic creations only is no longer true; on the contrary, copyright has taken on a life of its own and has become an important industrial asset because it covers, for example, computer programs, architectural drawings, engineering drawings and collections of data.⁶

10. “*Intellectual property*” is a catch-all phrase: That is not the end of the list. Conventions also deal with the protection of rights related to copyright (mentioned earlier); the rights of breeders of new varieties of plants;⁷ and

5 For a general discussion of the subject: Brad Sherman and Lionel Bently *The Making of Modern Intellectual Property Law - The British Experience, 1760-1911* (1999).

6 Computer programs and collections of data are covered by the WIPO Copyright Treaty, 1996.

7 International Convention for the Protection of New Varieties of Plants: www.upov.int.

rights in relation to semiconductor chip designs. It is thus understandable that some believe that the phrase “intellectual property” is a phrase best avoided if precision is required⁸because

“the term is a catch-all that lumps together several disparate legal systems, including copyright, patents, trademarks, and others, which have very little in common. These systems of law originated separately, cover different activities, operate in different ways, and raise different public policy issues.”⁹

Prof. David Vaver answered the question: “So what is intellectual property?” as follows:¹⁰

“The first thing to note is that, even today, there is no single legal entity going under that name. The phrase is really a handy shorthand for a whole slew of disparate rights – in the [Canadian] Commonwealth: some statutory, some common law, some equitable – which share the feature that they protect some products of the human mind, for varying periods of time, against use by others of those products in various ways. The general purpose of protection is to encourage those who may wish to create, finance or exploit such products to translate intent into act, particularly where they might otherwise not act at all, or act less often or less well, without the carrot of protection.”

This explains why some argue that IP law has only a utilitarian basis. According to Prof James Boyle, IP law lacks a coherent theoretical basis:¹¹

“Like most property regimes, our intellectual property regime will be contentious. It will have effects on market power, economic concentration and social structure. Yet, right now, we have no politics of intellectual property – in the way that we have a politics of the environment or of tax reform. We lack a conceptual map of issues, a rough working model of costs and benefits and a functioning coalition-politics of groups unified by common interest perceived in apparently diverse situations.”

11. *Folklore, traditional knowledge and genetic resources:* There is a move afoot to protect folklore, traditional knowledge and genetic resources as intellectual property. Some commentators have reservations about the move

8 *JWH Group Pty Ltd v Kimpura Pty Ltd* [2004] WASC 39 [Australia].

9 *Free Software, Free Society: The Selected Essays of Richard M Stallman* (ed J Gay).

10 *Intellectual Property: The State of the Art* [2001] VUWLReview2.

11 *A Politics of Intellectual Property: Environmentalism for the Net?* [1997] *Duke Law Review* 87.

– not because these are not worthy of protection but because of the difficulty of accommodating them under traditional IP concepts. Others do not.¹²

The main reason why it is thought that IP should accommodate these rights is because of a few misguided but dramatic attempts to monopolize aspects of ITK through patents (for turmeric), copyright in yoga moves (in the USA) and trademarks (in New Zealand of religious symbols). Although these instances support the argument, the answer is that these appropriations were more apparent than real. The inventions were not new, the works not original, and the trademarks *contra bonos mores*. Attempts at over-reaching (covetous claiming) are common in all IP fields.

The problem, on the other hand, is that these new order rights will create immutable and perpetual monopolies. Furthermore, the balances that IP systems have developed will not apply to them such as: the idea that what is in the public domain is open to all and may not be appropriated by anyone; that IP rights have a limited lifespan; that they may not be exploited against the public good; and that they must provide a *quid pro quo*.

Since these issues are still the subject of debate and negotiation at WIPO and nothing conclusive has eventuated, they are not dealt with in this work.¹³

12. *Subjects covered by this book:* The main areas of enforcement are in the field of trademarks, copyright, patents, designs and unfair competition, and these are dealt with in the subsequent chapters. The other areas mentioned do not give rise to much litigation and can be discounted for present purposes.

13. *Negative rights:* Intellectual property rights are generally referred to as negative rights.¹⁴

PANDUIT CORP v STAHLIN BROS

575 F.2d 1152 [USA]

Patents must by [US statute law] be given “the attributes of personal property”. The right to exclude others is the essence of the human right called “property”. The right to exclude others from free use of an invention protected by a valid patent does not differ from the

12 For example John T. Cross Property Rights and Traditional Knowledge *Potchefstroom Electronic Law Journal*, Vol. 13, No. 4, 2010: <http://ssrn.com/abstract=1772527>; GTZ publication *Triggering the Synergies between Intellectual Property Rights and Biodiversity* (2011): www.gtz.de/en/dokumente/gtz2010-en-iprs-and-biodiversity-reader.pdf.

13 Compare Adam Andrzejewski Traditional Knowledge and Patent Protection: Conflicting Views on International Patent Standards *Potchefstroom Electronic Law Journal* Vol. 13, No. 4, 2010: <http://ssrn.com/abstract=1772524>.

14 This issue is raised again under different headings in later chapters.

right to exclude others from free use of one's automobile, crops, or other items of personal property. Every human right, including that in an invention, is subject to challenge under appropriate circumstances. That one human property right may be challenged by trespass, another by theft, and another by infringement, does not affect the fundamental *indicium* of all "property", i.e., the right to exclude others.

Not everyone will agree with the assumption of Judge Markey that property rights are human rights but his statement is otherwise acceptable within the common-law tradition. But there is also another perspective, namely that these rights are in part positive and in part negative:¹⁵

"This monopoly is dual in nature: offensive, in that it entitles the rights to exploit the object on which it bears, either directly or through third party licenses; and also defensive since these same rights holders have legal tools at their disposal (particularly action for infringement) allowing them to oppose any unauthorized use of the object."

C. NATIONAL AND INTERNATIONAL LAW

14. Territoriality:¹⁶ Intellectual property law has a national and an international aspect. IP law is statute based (also in common-law countries) and IP laws are, accordingly, first and foremost territorial, and apply only within the particular jurisdiction.

"To begin with, one has to distinguish different aspects of 'the' territorial principle in IP. Its fundamental objective dimension means that an IP right is limited to the territory of the state granting it. The exclusive right can only cover activities occurring within the respective territory. No intangible subject matter is protected by one uniform right covering the whole world. Instead, technical inventions, works of literature and arts, signs, etc. are subject to a bundle of possibly more than 150 territorial rights of national or regional provenance. These rights are independent from each other so that an invention, work, etc. may be protected in one country, but in the public domain in another. A comparative study reveals that this objective territoriality has long been accepted in the EU, its Member States like Germany or the Netherlands, other European countries like Switzerland, common-law countries around the globe, Japan, and not least the U.S."¹⁷

15 Marie-Françoise Marais & Thibault Lachacinski *L'application des Droits de Propriété Intellectuelle* (WIPO publication 624(F)).

16 *Lucasfilm Ltd v Ainsworth* [2009] EWCA Civ 1328, [2011] UKSC 11; *Gallo Africa v Sting Music* [2010] ZASCA 96.

17 Alexander Peukert *Territoriality and Extraterritoriality in Intellectual Property Law*: <http://ssrn.com>.

This has given rise to jurisdictional problems especially in European Union markets, and as a result of modern technology, such as Internet trading. Other areas of dispute relate to contractual disputes related to IP rights, parallel importation and transit or transshipment of goods. There is also a tendency for some courts to claim jurisdiction over extra-jurisdictional infringements and although the US Supreme Court has recently put a brake to this,¹⁸ the Supreme Court of the UK thinks otherwise, at least as far as copyright is concerned.¹⁹

15. Conventions and treaties: Much of IP statute law is derived from international conventions and treaties. This has led to a large measure of conformity between laws, even between the civil and common law systems.

A major object of these conventions and treaties is to ensure that citizens and residents of one country receive recognition for and protection of their IP rights, more particularly, that a foreigner will be entitled to the same rights as those accorded to nationals. This is referred to as national treatment.

These international instruments also seek to harmonize IP laws and to provide for minimum levels of protection in all jurisdictions.

There is also the principle of the most-favored-nation treatment. The effect of this is that any advantage, favor, privilege or immunity granted by a member country (which is party to the TRIPS Agreement – see below) to the nationals of any other country is accorded unconditionally to the nationals of all other member countries. The TRIPS Agreement was the first agreement to adopt the most-favored-nation treatment as a principle in relation to the protection of IPRs.

16. Important conventions and treaties: Of importance for present purposes are the already mentioned Paris Convention of March 20, 1883, the Berne Convention, which dates back to September 9, 1886, and the more recent WIPO Copyright Treaty (WCT, 1996), the WIPO Performances and Phonograms Treaty (WPPT, 1996) and the TRIPS Agreement.²⁰ Other treaties administered by WIPO, such as the Patent Cooperation Treaty, the Trademark Law Treaty and the Treaty on the Law of Trademarks (Singapore, 2006) will not be discussed in any detail.²¹

D. THE TRIPS AGREEMENT

18 *Microsoft Corp v AT&T Corp* 550 US (2007) [USA].

19 *Lucasfilm Ltd v Ainsworth* [2011] UKSC 11; *Gallo Africa v Sting Music* [2010] ZASCA 96(27 July 2011).

20 Available at www.wipo.int and at www.wto.org for the TRIPS agreement

21 The treaties concerning rights related to copyright are mentioned later.

17. TRIPS obligations: Countries that are members of the World Trade Organization (WTO) are parties to the Agreement on Trade-Related Aspects of Intellectual Property Rights, also known as TRIPS. TRIPS requires of Members of the WTO to have laws in place that provide for different kinds of IP protection. The full range is not covered but the following are:

- copyright and related rights (section 1),
- trademarks (section 2),
- geographical indications (section 3),
- industrial designs (section 4),
- patents (section 5),
- layout-designs of integrated circuits (section 6), and
- the protection of undisclosed information (section 7).

Local laws have to comply with the minimum standards for IP protection laid down by TRIPS. In addition to the substantive provisions, and importantly, TRIPS places an obligation on Member countries to provide certain procedural remedies (most of which are fairly common in both the civil- and common-law traditions) that are to be at the disposal of rights holders.

18. The TRIPS Agreement sets minimum standards and Member countries are free to impose greater standards: Article 1.1 provides:

“Members shall give effect to the provisions of this Agreement. Members may, but shall not be obliged to, implement in their law more extensive protection than is required by this Agreement, provided that such protection does not contravene the provisions of this Agreement. Members shall be free to determine the appropriate method of implementing the provisions of this Agreement within their own legal system and practice.”

19. TRIPS compliance by Member States: For present purposes it will be assumed that all members of the WTO do comply with the minimum requirements laid down by TRIPS. This assumption is not necessarily correct for many reasons²².

Because local legislation has to comply with the TRIPS Agreement, TRIPS provides a benchmark for legislation and useful background material in interpreting IP statutes. Since these laws are in consequence based on the same treaty text, foreign judicial precedents are extremely valuable.

²² Attention is drawn, for instance, to the fact that, in accordance with Article 66 TRIPS, least-developed countries who are Members of the WTO have until 2013 to comply with the TRIPS provisions (and until 2016 for the provisions on pharmaceuticals), without prejudice to a further extension if so decided by the Council for TRIPS.

20. TRIPS Plus obligations: The TRIPS Agreement had some offspring. Some multilateral and bilateral agreements between states impose for commercial reasons additional IP enforcement obligations on those states. These are called TRIPS Plus Agreements because the obligations are more onerous than those envisaged by TRIPS.

The Directive 2004/48/EC of the European Parliament and of the Council of 29 April 2004 on the enforcement of IP rights sought to introduce a measure of standardization in relation to IP enforcement within the European Union:²³

- Member States must provide for the measures, procedures and remedies necessary to ensure the enforcement of the IP rights covered by the Directive.
- These must be fair and equitable and may not be unnecessarily complicated or costly, or entail unreasonable time-limits or unwarranted delays.
- They must also be effective, proportionate and dissuasive and must be applied in such a manner as to avoid the creation of barriers to legitimate trade, and to provide for safeguards against their abuse.

21. Anti-Counterfeiting Trade Agreement (ACTA): The latest development in this field is the Anti-Counterfeiting Trade Agreement, also known as ACTA. The object of the Agreement is to put in place international standards for enforcing intellectual property rights in order to combat counterfeiting and piracy more efficiently by improving international cooperation, establishing best practices for enforcement, and providing a more effective legal framework. The countries involved are mainly developed countries such as Australia, Canada, the European Union and its Member countries, Japan, Korea, Mexico, Morocco, New Zealand, Singapore, Switzerland, and the United States. ACTA has fierce critics. Because it will not be a multilateral agreement, but an agreement negotiated by a limited number of countries (mostly developed ones), it does not justify a discussion in this work.

E. REGISTERED AND UNREGISTERED RIGHTS

22. Formalities: Some IP rights depend for their recognition on the compliance of certain formalities while others are not dependent on any formalities. Patents, industrial designs and trademarks are registered rights and these rights are only enforceable once they have been granted

²³ The European Commission announced, in a communication of May 24, 2011, a wide-ranging strategy on IPR, including a review of the IPR Enforcement Directive in 2012 (see: http://ec.europa.eu/internal_market/copyright/docs/ipr_strategy/COM_2011_287_en.pdf).

(although in the case of trademark registrations the rights may have some retroactive effect). The subsistence of copyright, on the other hand, does not depend on any formalities such as registration. The difference is important because a copyright owner, although assisted by presumptions, must prove in each instance the subsistence of copyright and his claim to it while, in the case of registered rights, these may be proved simply by producing the certificate of grant. The onus rests on the person who wishes to attack the validity of a registration of a patent or trademark to prove the invalidity. (Some countries - like the USA and certain South American countries - have a copyright registration system for purposes of enforcement and for creating presumptions concerning the subsistence of copyright but not as a requirement for subsistence.)

F. CIVIL AND CRIMINAL LAW²⁴

23. Importance of criminal sanctions: Although IP rights are private rights and are enforceable by means of civil litigation, the prevalence of counterfeiting (which relates to trademark infringement) and piracy (that concerns copyright infringement) and the economic damage they cause has led to an increased importance of criminal sanctions. The infringement of other IP rights is generally not criminalized.

In this regard Justice Cao Jianming, at the time Vice President of the Supreme People's Court of the People's Republic of China, said extra-judicially:²⁵

“Protecting IP rights is necessary not only for China's honoring of its international promises, creating favorable trade and investment environment, and further opening up to the outside world, but also for promoting technical innovation, regulating the order of the market economy, improving the overall quality of the national economy, and enhancing the competitiveness. The people's courts at all levels should pay more attention to the criminal punishments on crimes of infringing on IP rights with clear-cut focuses. Cases seriously disrupting the market order and the economic development and cases with huge amounts involved and extremely serious circumstances and causing heavy losses to the State and the people, should be handled as major cases and the criminals involved should be convicted and sentenced according to law and in a prompt

24 Cf. Vichai Aryanuntaka *Enforcement of IP rights under Trips: A case study of Thailand*; Gregor Urbas *Public enforcement of IP rights* (2000) Australian Institute of Criminology No 177, both available on the internet.

25 *To Implement the Judicial Interpretation on the Protection of Intellectual Property Rights from the Perspective of Criminal Law, and Strengthening the Judicial Protection on IPR*, Dec 21, 2004; www.chinaipr.com/english/forum/forum63.htm.

manner. Various penal means should be used and a special emphasis on property punishments should be stressed. We should not only sentence such offenders in a determined manner but also make it economically impossible for the criminals convicted and sentenced to commit the crime again.”

G. IP RIGHTS AS BASIC HUMAN RIGHTS²⁶

24. No special status: Few legal systems accord any special treatment to IP rights.²⁷ Those with constitutions or other laws that protect basic human rights usually provide that no one may be deprived of property except in terms of a law of general application, and that no law may permit arbitrary deprivation of property. This means that, although no one has a basic human right or entitlement to IP rights, when they exist they are entitled to full legal protection.

25. Constitutional empowerment: Constitutions sometimes prescribe and delimit the power of the legislature in making IP laws. For instance, the US Constitution empowers Congress to adopt laws to “promote the progress of science and useful arts, by securing for limited times to authors and inventors the exclusive right to their respective writings and discoveries”²⁸ and IP laws can be tested against this prescript.²⁹

26. Impact of bills of rights: Bills of rights have a potential impact on the enforcement of IP rights, as have international human rights instruments such as the European Convention of Human Rights. IP laws are not immune to constitutional challenge. The basic rights usually in issue are the freedom of expression,³⁰ the right to privacy and the right to property.³¹ In countries that guarantee social rights, the impact may be greater and possible arguments about the scope and enforceability of pharmaceutical patents may arise in relation to the right to health care services or children’s rights; and copyright claims may have to be tested against the right to education and the right to access of information.

26 Cf. *Intellectual Property and Human Rights* (WIPO publication no 762 (E)) 1999.

27 Cf. Canada’s Constitution Act 1867 s 91(22) and (22).

28 Art. I, par. 8, cl. 8.

29 The issue is fairly complex: Thomas B Nachbar *Intellectual property and constitutional norms* [104] 2004 *Columbia LR* 272. For an Australian example: *Grain Pool of WA v The Commonwealth* [2000] 170 ALR 111 (HCA).

30 *Ashdown v Telegraph Group Ltd* [2001] EWCA Civ 1142 [England]; *Laugh It Off Promotions CC v SAB International (Finance) BV* [2004] ZASCA 76 and [2005] ZASCA 7 [South Africa]. Cf. *Lange v ABC* (1997) ALR 96 [Australia] discussed by Megan Richardson *Freedom of political discussion and intellectual property law in Australia* [1997] *EIPR* 631. Robert Burrell and Dev Saif Gangjee *Trade Marks and Freedom of Expression: A Call for Caution*: University of Queensland TC Beirne School of Law Research Paper No. 10-05: ssrn.com/abstract=1604886.

31 Pinto *The influence of the European Convention on Human Rights on intellectual property rights* [2002] *EIPR* 209.

H. THE JUSTIFICATION FOR THE RECOGNITION AND ENFORCEMENT OF IP RIGHTS

27. *The case for IP rights:* It does not fall within the scope of this work to set out the case either for or against the recognition of IP rights.³²The end of the debate is not near. As explained by Carlos M Correa:³³

“Empirical evidence on the role of intellectual property protection in promoting innovation and growth remains inconclusive. Diverging views also persist on the impacts of intellectual property rights on development prospects. Some point out that, in a modern economy, the minimum standards laid down in TRIPS will bring benefits to developing countries by creating the incentive structure necessary for knowledge generation and diffusion, technology transfer and private investment flows. Others stress that IP, especially some of its elements, such as the patenting regime, will adversely affect the pursuit of sustainable development strategies by: raising the prices of essential drugs to levels that are too high for the poor to afford; limiting the availability of educational materials for developing country school and university students; legitimizing the piracy of traditional knowledge; and undermining the self-reliance of resource-poor farmers.”

There is, however, a direct correlation between IP activity (for instance, the number of patent applications) in any given country and its economic development.

In the Gowers Report (December 2006), commissioned by the British Government, the case for IP rights is set out in these terms:

“Ideas are expensive to produce but cheap to copy. The fixed costs of producing knowledge are high. Hollywood blockbusters can cost hundreds of millions of dollars to make and research and development for drugs can cost billions of pounds. At the same time, the marginal costs of production, both for drugs and for digital files, are very low. Without protection, others will free ride on the creator’s initial investment and sell the invention or creation at a much lower cost. If the innovator knows that someone else can do this easily, there will be no financial incentive to innovate in the first instance.”

32 See especially *Intellectual Property: A Power Tool for Economic Growth* WIPO Publication No 888.

33 “Intellectual Property and Competition Law” ICTSD paper 21: iprsonline.org.

And as Stefan Scheytt said:³⁴

Eine Marke eintragen zu lassen ist kinderleicht, sie zu verteidigen eine Sisyphosaufgabe. (It is child play to register a trademark but to defend one is a Sisyphian task.)

GianCarlo Moschini made a similar point:³⁵

“The plight of the gifted and rich (and sometimes famous) usually fails to elicit much sympathy. But perhaps what is easily overlooked is that success is hard to win, and often harder to retain. This is very much the case for the products of human inventiveness and creativity – intangible assets that can be quite costly to obtain, that may be extremely valuable to society at large, but that can be copied and/or imitated very easily.”

Legal texts do not usually quote statements of politicians but this speech of the President of the Peoples’ Republic of China makes a clear case for the recognition and protection of IP rights where he stressed -

“strengthening the establishment of China’s intellectual property rights system and vigorously improving its ability to create, manage, protect, and apply intellectual property rights is an urgent need for augmenting China’s creativity and building a creative country; is an urgent need for perfecting the socialist market economic system, standardizing the market order, building a trustworthy society, strengthening our enterprises’ market competitiveness, and enhancing the country’s core competitiveness; and is also an urgent need for widening the opening up scope and achieving reciprocal win-win results. There is a need to fully display the important role of intellectual property rights in improving the country’s economic, scientific, and technological strength and international competitiveness and in safeguarding national interests and economic security, so as to provide powerful support for China in joining the ranks of creative countries. ”³⁶

Of especial importance is the protection given to pharmaceutical patents in developing countries. The issue forms part of the Doha Declaration (and uncompleted) negotiations.³⁷ The Doha Declaration recognized that under TRIPS each Member State has the right to grant compulsory patent licenses;

34 www.brandeins.de/home/.

35 Intellectual Property Rights and the World Trade Organization: Retrospect and Prospects – Working Paper 03-WP 334 May 2003.

36 May 27, 2006: 31st collective study of the CCP Central Committee’s Political Bureau.

37 For particulars see www.wto.int.

has the freedom to determine the grounds upon which such licenses are granted; and has the right to determine what constitutes a national emergency or other circumstances of extreme urgency for this purpose. It was also understood that public health crises, including those relating to HIV/AIDS, tuberculosis, malaria and other epidemics, can represent a national emergency or circumstance of extreme urgency (An amendment to TRIPS relating to compulsory licenses for pharmaceutical products has been agreed to by the Council of WTO during December 2005 but still has to be accepted by its members.).

The debates at the World Health Organization (WHO) are proof of a growing disagreement between countries about the justification of the protection of at least some IP rights. They also show that within individual governments there are conflicting views. Those responsible for economic growth are in favor of the protection of IP rights while those concerned with health issues are opposed thereto. Although the WHO had created a global coalition of stakeholders called IMPACT (International Medical Products Anti-Counterfeiting Taskforce) to combat counterfeit medicines there was a growing antipathy from some quarters against IMPACT. In January 2012, the WHO Executive Board agreed to propose to the WHO General Assembly the establishment of a new mechanism for international collaboration on counterfeit and substandard medical products, though excluding trade and intellectual property issues.³⁸

28. *IP rights and monopolies:* This quotation deals with patents but the same point is later made in relation to trademarks.

PANDUIT CORP v STAHLIN BROS

575 F.2d 1152

It is not uncommon for an infringer to wrap itself in the mantle of public defender against “monopoly”, in reliance on an unthinking monopoly-phobia it mistakenly hopes to find in the courts. The loose application of the pejorative term “monopoly”, to the property right of exclusion represented by a patent, can be misleading. Unchecked it can also destroy the constitutional and statutory scheme reflected in the patent system.

If the patent be valid, it takes nothing from the public, as does the “monopoly” against which our anti-trust laws are directed. On the contrary, it gives to the public, by definition, that which the public never before had. That a patent, like stocks, bonds and other property,

³⁸ See: http://apps.who.int/gb/ebwha/pdf_files/EB130/B130_R13-en.pdf. The WHO General Assembly will meet to discuss this new mechanism, in May 2012.

may be misused in a plan [in violation] of an anti-trust law does not render the property right in the patent a monopoly in the anti-social, anti-competitive sense, any more than it does the property right in stocks and bonds. Absent the incentive to disclose provided by the patent system, the public might never learn of many inventions, all of which reside first in the inventor's mind and over which he could maintain a permanent "monopoly" by simply telling no one, or, if the invention permits, by keeping it a trade secret forever.

The impression is often created that IP enforcement is about a conflict between the strong and the weak, the rich and the poor. It is seldom the case:

This [particular case] is not a moral tussle between the good and the bad, the small and the large. It is a fight over profits by competitors.³⁹

29. *Balancing of rights and obligations:* The objectives of TRIPS are such as to require a balancing of rights and obligations (Art. 7):

"The protection and enforcement of intellectual property rights should contribute to the promotion of technological innovation and to the transfer and dissemination of technology, to the mutual advantage of producers and users of technological knowledge and in a manner conducive to social and economic welfare, and to a balance of rights and obligations."

BRISTOL-MYERS SQUIBB CO v CANADA (ATTORNEY GENERAL)

2005 SCC 26 [Canada]

Our court has often spoken of the balance struck under the Patent Act in which the public gives an inventor the right to prevent anybody else from using his or her invention for a period of 20 years in exchange for disclosure of what has been invented. As a general rule, if the patent holder obtains a monopoly for something which does not fulfill the statutory requirements of novelty, ingenuity and utility, then the public is short-changed.

In the present appeal, the court is required to consider this "balance" in the much-litigated field of patented medicines, where Parliament is concerned not only with the balance between inventors and potential users, but between the protection of intellectual property on the one hand and, on the other hand, the desire to reduce health

39 *BoehringerIngelheim KG v Swingward Ltd* [2000] FSR 529 par 9.

care costs while being fair to those whose ingenuity brought the drugs into existence in the first place.

METRO-GOLDWYN-MAYER STUDIOS INC v GROKSTER LTD

380 F.3d 1154

The more artistic protection is favored, the more technological innovation may be discouraged; the administration of copyright law is an exercise in managing the trade-off.

SUPREME COURT, THE FIRST PETTY BENCH, JAPAN

Case: 2001(Ju)No.952

MinshuVol 56 No 4 808:

The protection of the rights of the copyright holder by the Copyright Law needs to be realized in harmony with public and social interests.

30. Abuse of rights: Legislatures are entitled to promote certain public interests and prevent the abuse of rights. Article 8 of the TRIPS Agreement provides in this regard:

- Members may, in formulating or amending their laws and regulations, adopt measures necessary to protect public health and nutrition, and to promote the public interest in sectors of vital importance to their socio-economic and technological development, provided that such measures are consistent with the provisions of this Agreement.
- Appropriate measures, provided that they are consistent with the provisions of this Agreement, may be needed to prevent the abuse of intellectual property rights by right holders or the resort to practices which unreasonably restrain trade or adversely affect the international transfer of technology.

31. IP rights and competition law:⁴⁰ It has been said that the fact that you own a hammer does not entitle you to hit someone else over the head with it. The same applies to IP rights. An IP right, like any other right, may not be used in such a manner that it breaches competition laws.⁴¹ This is confirmed by Article 8.2 of the TRIPS Agreement, which states that “appropriate measures, provided that they are consistent with the provisions of this Agreement, may be needed to prevent the abuse of intellectual property rights by right holders or the resort to practices which unreasonably restrain

40 In general Pierre Régibeau & Katharine Rockett *The Relationship between Intellectual Property Law and Competition Law: An Economic Approach*: essex.ac.uk/economics/discussion-papers/.

41 *Orange Book Standard Case KZR 39/06* May 6, 2009 [BGH].

trade or adversely affect the international transfer of technology.” Article 40, in addition, provides for the possibility of regulating restrictive practices in licensing agreements.

It may be argued, says Prof. Correa,⁴²

“that the very purpose of IPRs is to restrict third parties’ use of technologies and other protected assets and that, therefore, such exclusionary right should be preserved unfettered and exempted from competition law challenges. However, ‘[T]he fact that intellectual property laws grant exclusive rights of exploitation does not imply that intellectual property rights are immune from competition law intervention.’ Intellectual property rights are, in effect, not absolute but subject to higher public interests. Moreover, IPRs are granted to serve public interests *through inventors and creators and not just to benefit them. Thus, in an important case, the US Supreme Court stated that “[T]he basic quid pro quo contemplated by the Constitution and the Congress for granting a patent monopoly is the benefit derived by the public from an invention with substantial utility.*”⁴³

32. Justifying enforcement: Rights have no value unless they can be enforced effectively, and since IP rights are internationally and statutorily recognized rights they must be respected, irrespective of their exclusivity. Judges and others with an anti-monopolistic mindset should beware that their mindset does not contaminate their attitude towards rights holders. IP litigation –

“presents a significant direct link between judicial system performance and economic development. That is to say, the validity of intellectual property protection depends heavily on judicial system performance. For intellectual property rights to serve their purpose, effective judicial support is needed. A right without a remedy turns out to be an expensive fantasy. When judicial support for these specialized rights is feeble, mobilization of that natural resource falters, with considerable losses to the country.”⁴⁴

“Just as a donkey will not chase after a carrot on a stick unless he is allowed to catch it once in a while, innovators will not invest in inventing, development, implementing and marketing new technology unless they believe the patent promise to be real. If innovators find that patents are

42 *Op. cit.*

43 *Brenner v Manson 383 US 519, 534-35 (1966).*

44 Robert M Sherwood *The economic importance of judges*, paper read at International Judges’ Conference on IP Law, Washington DC, Oct 1999. There are a number of studies on this aspect published by the World Bank and the International Finance Corporation. Not all agree.

only licenses to spend money in pursuing court actions, patents will fail to fulfill their promise to stimulate innovation.”⁴⁵

In addition, as will appear from the chapters dealing with counterfeiting and piracy, the infringement of IP rights is often the result of criminal activities that impinge on other public interests such as the prevention of organized crime, public health concerns and the protection of the public purse.

33. *IP rights are not absolute:* IP rights are not supreme and “we must stop thinking of intellectual property as an absolute and start thinking of it as a function”.⁴⁶

Excessive control by holders of copyright and other forms of intellectual property may unduly limit the ability of the public domain to incorporate and embellish creative innovation in the long-term interests of society as a whole, or create practical obstacles to proper utilization.⁴⁷

Among the precedents quoted the reader will from time to time find useful instances where courts have embarked on this balancing act.

34. *The right to imitate:* Aristotle in *Περὶ ποιητικῆς* (*Ars Poetica* in Latin), written in about 335 BCE, already recognized that we all learn by imitation.

LORIMAR PRODUCTIONS INC v STERLING CLOTHING MANUFACTURERS (PTY) LTD

1981 (3) SA 1129 (T) [South Africa]

Not all imitation is unlawful. On the contrary, imitation may be said to be the essence of life. From the cradle to the grave man imitates his fellow-men in speech and song, habits, fashions and fads. Imitation is also, therefore, legitimate in business, up to a point.

35. *The overlap of rights:* The same commercial object may incorporate or reflect different IP rights and the same intellectual endeavor may be protected by more than one IP right. For instance, a label may be entitled to trademark and copyright protection and a container may be entitled to both trademark and design protection. This, however, does not justify the blurring of the differences between the different IP rights; each must be kept within its strict statutory limits.⁴⁸

45 Norman L Balmer, paper read at the same International Judges' Conference on IP Law.

46 Per McLachlin CJC quoted by David Vaver *Canada's intellectual property framework: a comparative overview* [17] *Intellectual Property Journal* 125 187.

47 *Theberge v Galeries d'Art du Petit Champlain 2002 SCC 34 [Canada]* discussed by David Vaver “Need intellectual property be everywhere? Against ubiquity and uniformity” [25] *2002 Dalhousie Law Journal* 1.

48 *Roland Corp. v. Lorenzo & Sons Pty Ltd* (1991) 105 ALR 623, affirmed (1992) 23 IPR 376 [Australia].

KIRKBI AG v RITVIK HOLDINGS INC

2005 SCC 65 [Canada]

The vast and expanding domain of the law of intellectual property is going through a period of major and rapid changes. The pressures of globalization and technological change challenge its institutions, its classifications and sometimes settled doctrines. Jurisprudence attempts to address – sometimes with difficulty – the consequences of these broad social and economic trends. The state of patent law is evidence enough of the stresses on the process of jurisprudential development in a world where statute law itself struggles to catch up with the life of laboratories and markets. The economic value of intellectual property rights arouses the imagination and litigiousness of rights holders in their search for continuing protection of what they view as their rightful property. Such a search carries with it the risk of discarding basic and necessary distinctions between different forms of intellectual property and their legal and economic functions. The present appeal is a case in point. It involves the distinction between patents and trademarks.

RUCKER CO v GAVEL'S VULCANIZING LTD

(1985) 7 CPR 3d 294 [Canada]

I strongly believe that it was not the intention of Parliament, nor from a practical view is it desirable, that the Patent Act, the Copyright Act, and the Industrial Design Act should be interpreted so as to give overlapping protection. Something suitable for industrial design cannot be registered for copyright, as that statute states, and something for which a patent is granted should not also be given double protection for an extended period of time by registering for copyright drawings from which the patented object was made.

36. *The problem of weak rights:* Teresa Scassa pointed to the danger of weak rights:

“A second main area for consideration is the expansion of intellectual property protection by means of the deliberate exercise of weak, uncertain or unfounded intellectual property claims. This activity can occur in a broad range of contexts, and has become a matter of increasing concern. In such cases, the extension of intellectual property rights arises through deliberate action of parties, yet there are also deficiencies in the legal regimes that contribute to the ability of parties to extend their rights in this manner. Some of these deficiencies include

uncertainty as to the scope of protection or the scope of legal defenses, and systemic shortcomings in the granting of rights.”⁴⁹

I. JURISDICTION

37. *Jurisdiction and territoriality:* The point has already been made that IP rights are territorial. That does not mean that there cannot be jurisdictional issues because it is necessary to distinguish between judicial competence and legislative competence.

“One of the basic tenets of private international law is the distinction between personal jurisdiction (judicial competence) of the court and the applicable law (legislative competence). In intellectual property, such a distinction was often ignored, mainly because of the principle of territoriality, under which the forum was most often the place of the injury and the applicable law was generally assumed to be the law of the forum State. But with the increasing advent of infringements that have a simultaneous impact on multiple territories, assertion of judicial competence over a multi-territorial infringement is increasingly likely to be sought, and courts will have to consider what law or laws apply to the full territorial extent of the claim.”⁵⁰

38. *The rise of transnational IP infringement:*

“First, digital media may produce ubiquitous infringements of intellectual property rights, and thereby create transnational cases that require courts to interpret foreign law or to adjudicate the effect of foreign activities. Second, the rights at issue may encompass the range of intellectual property regimes. While transnational copyright and trademark claims are by now well known, this example shows that patent infringements are no longer as territorially discrete as was once assumed. Third, the potential impact of the alleged infringements in every State in the world may make effective enforcement (or defense) elusive. There may be no single court with full adjudicatory authority over worldwide copyright, patent, and trademark claims. Even if there were, the choice-of-law issues may prove excessively complex (or, paradoxically, misleadingly simple, if a court entertaining all or part of a worldwide dispute yielded to the temptation to apply its own law to

49 Teresa Scassa *Extension of intellectual property rights* prepared for the Competition Bureau of Canada and Industry Canada, April, 2007 (unpublished).

50 The American Law Institute *Intellectual Property: Principles Governing Jurisdiction, Choice of Law, and Judgments in Transnational Disputes Proposed Final Draft (March 30, 2007)*.

the entire case). In contrast, State-by-State adjudication may make the choice-of-court and choice-of-law issues appear easier to resolve, but multiple adjudication could produce uncertainty, inconsistency, delay, and expense. Moreover, multiple suits involving the same claims and incidents strain judicial dockets.”⁵¹

39. Laws and conventions concerning jurisdiction: Jurisdiction is usually dependent on the particular laws of a given country and in the USA, for instance, it may depend on the federal structure of the country.⁵²

Within the European Union (and some other countries) the matter is determined or influenced by the Brussels Convention on Jurisdiction and the Enforcement of Judgments in Civil and Commercial Matters 1968 and the Lugano Convention on Jurisdiction and the Enforcement of Judgments in Civil and Commercial Matters. These have to some extent been superseded by the Brussels Regulations.⁵³

Relevant for present purposes is the fact that, irrespective of domicile, in proceedings concerned with the registration or validity of patents, trademarks, designs or other similar rights required to be deposited or registered, the courts of the Member State in which the deposit or registration has been applied for, has taken place or is under the terms of a European Union instrument or an international convention deemed to have taken place, have exclusive jurisdiction. These conventions and rules do not deal with unregistered rights such as copyright and related rights. The relevant provisions are:

- Article 2: Subject to the provisions of the Convention, persons domiciled in a Contracting State must, whatever their nationality, be sued in the courts of that State.⁵⁴
- Article 16(4): In proceedings concerned with the registration or validity of patents, trade-marks, designs, or other similar rights required to be deposited or registered, the courts of the Contracting State in which the deposit or registration has been applied for, has taken place or is under the terms of an international convention deemed to have taken place, have exclusive jurisdiction, regardless of domicile.⁵⁵

51 The American Law Institute *op cit*.

52 Cf. *T B Harms Company v Eliscu* 339 F.2d 823. On Internet trading across state borders: *Zippo Manufacturing Company v Zippo Dot Com Inc* 952 F Suppl 1119 [USA].

53 See Council Regulation (EC) No 44/2001 of 22 December 2000 on Jurisdiction and the Recognition and Enforcement of Judgments in Civil and Commercial Matters (Brussels 1 Regulation): <http://eur-lex.europa.eu/LexUriServ/LexUriServ.do?uri=CONSLEG:2001R0044:20100514:EN:PDF>.

54 Corresponding to Article 2(1) of the Brussels 1 Regulation.

55 Corresponding to Article 22(4) of the Brussels 1 Regulation.

The proposed Hague Convention on Choice of Court Agreements provides for a choice of forum on a consensual basis. It, in turn, excludes matters of “validity of intellectual property rights other than copyright and related rights” from the scope of its application, which means that the excluded matters may not be dealt with by a court as a result of consent to jurisdiction.⁵⁶

40. Basic jurisdictional principles: The first rule of jurisdiction is that the court of residence or domicile of the defendant is the primary court with jurisdiction. This means that a court must have jurisdiction over the person of the defendant.

In addition a court must have subject-matter jurisdiction. The law applicable to determine the existence, validity, duration, attributes, and infringement of intellectual property rights and the remedies for their infringement is:

- for registered rights, the law of each state of registration.
- for other intellectual property rights, the law of each state in and for which protection is sought.

Although it appears to be generally accepted that a court does not have jurisdiction to try foreign patent or trademark cases even if the defendant is resident within its jurisdiction, the views about whether a court has subject-matter jurisdiction to hear a foreign copyright infringement even if it has jurisdiction over the person of the defendant differ.⁵⁷ The law applicable to a non-contractual obligation arising out of an act of unfair competition is the law of each state in which direct and substantial damage results or is likely to result, irrespective of the state or states in which the act giving rise to the damage occurred.⁵⁸

Contractual disputes concerning IP rights may be decided by the court that has jurisdiction over the parties to the contract.

41. Case law on the Brussels and Locarno Conventions: The European Court of Justice had to deal with the issue of jurisdiction in two important decisions. In the first⁵⁹ it held that a German court was not entitled to determine the consequences of an alleged patent infringement activity in France when the case required a determination of the validity of a French patent and in the

56 Stefan Luginbuehl & Heike Wollgast *The Hague Convention on Choice of Court Agreements: Perspectives for IP Litigation Festschrift für Jochen Pagenberg* (2006) 321-350.

57 *Lucasfilm Ltd v Ainsworth* [2009] EWCA Civ 1328 overruled by *Lucasfilm Ltd v Ainsworth* [2011] UKSC Civ 11. See also *Gallo Africa v Sting Music* [2010] ZASCA 96.

58 The American Law Institute *Intellectual Property: Principles Governing Jurisdiction, Choice of Law, and Judgments in Transnational Disputes* Proposed Final Draft (March 30, 2007).

59 ECJ, 13 July 2006, *Gesellschaft für Antriebstechnik mbH & Co KG / Lamellen und Kupplungsbau Beteiligungs KG*, C-4/03, ECR 2006, I-6509.

second it held that a Dutch court was not entitled to join foreign defendants to a patent infringement suit involving a resident defendant.⁶⁰

On the other hand, *Duijnstee v Goderbauer*⁶¹ concerned a dispute between an inventor and the liquidator of a company about the ownership of patents. The liquidator's claim was that under Dutch law the inventions had been made on terms that the patents ought to belong to the company. He demanded that the inventor should be ordered to transfer not only the Dutch patent, but also the corresponding patents in 22 other countries, including five which had adhered to *the Brussels Convention Relating to the Distribution of Programme-Carrying Signals Transmitted by Satellite (1974)*. The ECJ held that to make the order would not violate Article 16(4) of the Convention. The validity of the patents was not being challenged. Nor, for that matter, was the conduct of the various national authorities whose business it was to keep the patent registers challenged. Nor was the liquidator seeking an order directing those authorities to rectify their registers in the light of Dutch law. Instead, the liquidator was asking for an order which would have required the inventor himself to apply to rectify the registers: an order *in personam*.⁶²

VODAV CORDISCORP

476 F.3d 887 (Fed. Cir. 2007)

The Paris Convention thus clearly expresses the independence of each country's sovereign patent systems and their systems for adjudicating those patents. Nothing in the Paris Convention contemplates nor allows one jurisdiction to adjudicate the patents of another, and as such, our courts should not determine the validity and infringement of foreign patents. Accordingly, while the Paris Convention contains no express jurisdictional-stripping statute, we relied on it in *Stein* to hold that "[o]nly a British court, applying British law, can determine validity and infringement of British patents."

Regardless of the strength of the harmonization trend, however, we as the U.S. judiciary should not unilaterally decide either for our government or for other foreign sovereigns that our courts will become the adjudicating body for any foreign patent with a U.S. equivalent "so related" to form "the same case or controversy." Permitting our district courts to exercise jurisdiction over infringement claims based on foreign patents in this case would require us to define the legal boundaries of a property right granted by another sovereign and then determine whether there has been a trespass to that right.

60 ECJ, 13 July 2006, *Roche Nederland and others / Primus and Milton Goldenberg.*, C-539/03, ECR 2006, I-6535.

61 ECJ, 15 November 1983, *Duijnstee*, 288/82, ECR 1983, 3663.

62 Taken from *R Griggs Group Ltd v Evans (No 2) [2004] EWHC 1088 (Ch)*.

In this case, these considerations of comity do not support the district court's exercise of supplemental jurisdiction over Voda's foreign patent infringement claims.

PEARCE v OVE ARUP PARTNERSHIP LTD

[1999] EWCA Civ 625 [UK]

It is different in respect of copyright under the Brussels Convention

The English court has jurisdiction to hear an action against a defendant who is domiciled in England in respect of the infringement in Holland of a Dutch copyright. That must follow from the provisions in Articles 2 and 16(4) of the Brussels Convention.

That this exclusive jurisdiction is based on considerations of sovereignty is made clear by the commentary in the Jenard Report:

"Since the grant of a national patent is an exercise of national sovereignty, Article 16(4) of the Judgments Convention provides for exclusive jurisdiction in proceedings concerned with the validity of patents. Where proceedings are concerned with the registration or validity of patents, trademarks, designs or other similar rights required to be deposited or registered the local court has exclusive jurisdiction.

But where the action is not concerned with registration or validity, the Convention gives jurisdiction to the courts of the defendant's domicile; or to the courts of other Contracting States in accordance with Articles 5 and 6. The question 'can the English court inquire into the validity of a patent granted by a Contracting State' is answered by Article 16(4). The question 'does the English court have jurisdiction to entertain proceedings in respect of the alleged infringement of an intellectual property right conferred by the law of a Contracting State where the proceedings fall outside Article 16(4),' is answered by Articles 2, 5 or 6."

J. THE EDITORIAL POLICY

42. *Selection of precedents:* Precedents that state general propositions and not merely parochial ones were, as far as possible, chosen. The reader will notice that the precedents used are from a limited number of jurisdictions. The reason for the selection of any particular judgment is often fortuitous but the degree of judicial activity in the field of IP because of economic factors, and the availability of judgments, especially on the Internet were usually determinative.

It is part of the common-law tradition to name the judge who wrote the judgment; while in the civil-law countries there is no indication of who was responsible for composing the judgment (sometimes the names of the judges who heard the case are not even given). In some jurisdictions the same names crop up regularly. This is because in those courts the IP judgments are usually allocated to the same judges to write. The civil-law tradition will be followed.

43. *Selection of statutes:* Statutes from different jurisdictions have been chosen in order to illustrate different points. The basis of selection was to find a statute that would be representative of the law or to illustrate a novel or different approach. Accessibility was also a factor and those quoted can be found on the Internet.

44. *Insertions and omissions:* Except for a few instances, the extracts from judgments are relatively short and do not deal with the facts of the case. Facts are given if necessary for understanding the extract. In a chapter such as on patents, very few facts are stated because the facts are difficult to restate and add little to an understanding of the underlying principle. Square brackets [] indicate the few insertions.

In order to improve readability omissions are not shown. Words, phrases and paragraphs have been omitted in order to create (what the author wishes to believe) a userfriendly text. So, too, long paragraphs have been broken up into shorter ones and if a judgment dealt with more than one issue, the judgment may have been subjected to the same treatment. And bullets have been used instead of numbering where appropriate.

Page references have been omitted because of the predominant use of electronic text.

45. *Spelling and style:* The author's text is in US English because that is the house style of WIPO. This means, for instance, that the noun "licence" is given as "license" and "favour" as "favor". In the quotations the original spelling has, as far as practicable, been retained although a few changes to spelling and style were made for the sake of uniformity. Likewise, the citations within quotations were, if not omitted, standardized.

46. *Repetition:* Acting on the assumption that this book will be used as a reference work only and will not be read like a novel, there is some repetition of material in order to improve the coherence of a particular subject.

K. USEFUL WEBSITES

47. *The following internet sources are useful:* They all provide free access to laws, law reports and related material. But if all else fails a search on a general search engine may produce something useful.

An important academic site is the Social Sciences Research Network:

www.ssrn.com

These sites are especially important for treaties and conventions and judgments of the Court of Justice of the European Union and judgments on domain name decisions:

World Intellectual Property Organization (WIPO): www.wipo.int

World Trade Organization (WTO): www.wto.int

Internet Domain Name Arbitration Decisions (2000-):

www.arbiter.wipo.int/domains/

Court of Justice of the European Union (ECJ)⁶³:

http://curia.europa.eu/jcms/jcms/lj_6/

WIPO has a non-exhaustive compilation list that provides links to publicly and freely accessible online databases: www.wipo.int/enforcement/en/case_law.html

The Free Access to Law movement provides what it promises in relation to mainly English-speaking law reports. The general access site with links to the different Legal Information Institutes is: www.worldlii.org.

Particular countries:

Asia: www.asianlii.org/

Australia: www.austlii.edu.au

Belgium: <http://www.juridat.be/>

Brazil: www.stf.gov.br/jurisprudencia/consulta/juris.asp

Canada: www.canlii.org/

France: <http://www.legifrance.gouv.fr/initRechJuriJudi.do>

⁶³ It contains the case-law of both the Court of Justice and the General Court (the new denomination of the Court of First Instance since December 1, 2009). These two courts are competent to render judgments in IP matters. For more information on the respective role of these courts, see: http://curia.europa.eu/jcms/jcms/Jo2_6999/

INTRODUCTION

Germany: www.ipwiki.de; www.bundesgerichtshof.de

Hong Kong: www.hklii.org/

India: judis.nic.in/supremecourt/chejudis.asp

Ireland: www.ucc.ie/law/irlii/index.php

Japan: <http://database.iip.or.jp/cases/>

Netherlands: <http://zoeken.rechtspraak.nl>

New Zealand: www.nzlii.org/

Pacific Islands: www.paclii.org/

Portugal: www.dgsi.pt/

Singapore: www.commonlii.org/sg/cases/

Southern Africa countries: www.saflii.org

Spain: www.poderjudicial.es/jurisprudencial

United Kingdom and Ireland: www.bailii.org

United States of America: www.law.cornell.edu/; www.findlaw.com.

Counterfeiting and piracy: A number of sites provide useful information on matters related to counterfeiting and piracy. These are some of them:

www.wipo.int/enforcement/en/

http://ec.europa.eu/internal_market/iprenforcement/observatory/index_en.htm

www.oecd.org/

www.ccapcongress.net

www.iccwbo.org/bascap

www.cybercrime.gov.

www.usdoj.gov/criminal/cybercrime/ipmanual/

TRADEMARKS: GENERAL PRINCIPLES

CHAPTER II

- A. TREATIES AND LEGISLATIVE TEXTS (1-7)
- B. THE NATURE OF TRADEMARKS (8-15)
- C. THE FUNCTION OF TRADEMARKS (16-22)
- D. THE ESSENTIALS OF TRADEMARKS (23-27)
- E. WHAT IS NOT A TRADEMARK? (28-31)
- F. THE DOCTRINE OF FUNCTIONALITY (32-33)
- G. OWNERSHIP AND REGISTRATION (34-38)

A. TREATIES AND LEGISLATIVE TEXTS

1. *TRIPS requirements*: It is a requirement of the TRIPS Agreement that Members of the WTO must have legislation in place that provides for trademark protection.⁶⁴ TRIPS also provides for certain minimum requirements to which trademark laws must comply. The discussion that follows takes these minimum requirements as its starting point. The provisions of TRIPS relevant to trademarks will be quoted during the course of the discussion.

2. *Paris Convention*: Another important aspect of TRIPS (Art. 2.1) is that it requires of Member States to comply with certain provisions of the 1967 text of the Paris Convention.⁶⁵ This obligation exists irrespective of whether or not the particular state is a member of the Paris Convention. A similar obligation flows from the provisions of the Trademark Law Treaty (1994) and the Singapore Treaty on the Law of Trademarks.

3. *National treatment*: TRIPS (Art. 3.1), like the Paris Convention, requires that each Member State must, in relation to the protection of trademark rights, treat nationals of other Member States no less favorably than it treats its own nationals. This is referred to as “national treatment”.

4. *EU directive*: The European Union has a directive on trademark law; and the laws of all Members of the EU have to be in conformity with the Directive.⁶⁶ The Directive, which complies with TRIPS, but provides for some broader trademark protection, forms the basis of the trademark jurisprudence of the European Court of Justice (ECJ) and the modern laws and jurisprudence of the Members of the EU (including two common-law countries, the United Kingdom and Ireland).⁶⁷

Reference could also be had to the Council Regulation (EC) no 207/2009 on the Community trade mark, which deals in clear terms with many of the applicable trademark concepts.⁶⁸

5. *ECJ judgments*: Reference will, from time to time, be made to the terms of the Directive, and ECJ judgments will be cited. These are easily accessible on the Internet.⁶⁹ It should, however, be borne in mind that the ECJ⁷⁰ is

64 For the sake of consistency the term “trademark” is used, both as an adjective and a noun, and all uses of “trade mark” have been changed accordingly.

65 *The Paris Convention for the Protection of Industrial Property* of March 20, 1883 as revised available at www.wipo.int.

66 www.oami.eu.int/.

67 Directive 2008/95/EC of the European Parliament and of the Council of 22 October 2008 to approximate the laws of the Member States relating to trade marks, replacing the First Council Directive 89/104/EEC of 21 December 1988: <http://eur-lex.europa.eu/LexUriServ/LexUriServ.do?uri=OJ:L:2008:299:0025:0033:EN:PDF>.

68 <http://eur-lex.europa.eu/LexUriServ/LexUriServ.do?uri=OJ:L:2009:078:0001:0042:EN:PDF>.

69 http://curia.europa.eu/jcms/jcms/lj_6/.

70 The Court of Justice must be distinguished from the General Court. For more information on this distinction, see: http://curia.europa.eu/jcms/jcms/Jo2_6999/

essentially a *cour de cassation* because one of its functions is to answer legal questions put to it by the national courts of its Member States in relation to the scope of Union laws and regulations. The judgments are, consequently, of importance as legal expositions concerning matters of principle but (unless they are concerned with an internal appeal) give limited practical guidance to the final outcome of any particular case.

6. *Basis of the UK Trademarks Act:* The UK Trademarks Act 1994 is an instance of a statute which complies with both the TRIPS Agreement and the EU Directive, and the substantive provisions of this Act will be used as a point of departure. By its very nature it represents an amalgam of civil and common law principles but it is in all material respects identical to the laws of the other EU countries.

7. *The hybrid origin of the UK Act:*

LOTTO (UK) LTD v CAMELOT GROUP PLC

[2003] EWCA Civ 1132 [UK]

As that summary makes clear, the 1994 Act is a hybrid. There are two main European sources: the Directive, aimed at harmonization of the national trademarks laws, and the Regulation, introducing the new Community trademark. However, many of the basic concepts are derived, in some cases solely, from previous domestic law. Old authorities may be of assistance, but “it should not be forgotten at any point that the system is fundamentally different and frequently demands a fresh look.”⁷¹

B. THE NATURE OF TRADEMARKS

8. *Trademarks are intangible property and have a commercial value:* This principle is expressly stated in some laws⁷² but is also the result of a historical development described by Christopher Wadlow:⁷³

“In a series of cases Lord Westbury L.C. ‘surprised the profession’ by holding that there was a right of property in trademarks which was transmissible and enforceable even against innocent infringement. Perhaps Lord Westbury would also have recognized property in trade names, and if so the whole of the law of passing-off as it

71 Quoting *Kerly’s Law of Trademarks and Trade Names* 13 ed. para 1.11.

72 In the UK in s 2(1): “A registered trademark is a property right obtained by the registration of the trademark under this Act” and s 22: “A registered trademark is personal property (in Scotland, incorporeal moveable property).”

73 Quoted in *Inter Lotto (UK) Ltd v Camelot Group Plc* [2003] EWHC 1256 (Ch).

was then understood could have been re-interpreted in terms of infringement of property rights as opposed to misrepresentation. That, however, was not to happen. The law of trademarks was put on a statutory basis, the law of passing-off continued in terms of misrepresentation.”

The European Court of Human Rights had to consider whether an application for the registration of a trademark created proprietary rights. It held that it did. This reasoning applies *a fortiori* to registered trademarks.

ANHEUSER-BUSCH v PORTUGAL

European Court of Human Rights Grand Chamber

June 28, 2006

The Court takes due note of the bundle of financial rights and interests that arise upon an application for the registration of a trademark. It agrees that such applications may give rise to a variety of legal transactions, such as a sale or license agreement for consideration, and possess – or are capable of possessing – a substantial financial value. With regard to the submission that dealings in respect of applications for the registration of a mark are of negligible or symbolic value only, it is noted that in a market economy, value depends on a number of factors and it is impossible to assert at the outset that the assignment of an application for the registration of a trademark will have no financial value.

These elements taken as a whole suggest that the applicant company’s legal position as an applicant for the registration of a trademark gave rise to interests of a proprietary nature. It is true that the registration of the mark – and the greater protection it afforded – would only become final if the mark did not infringe legitimate third-party rights, so that, in that sense, the rights attached to an application for registration were conditional. Nevertheless, when it filed its application for registration, the applicant company was entitled to expect that it would be examined under the applicable legislation if it satisfied the other relevant substantive and procedural conditions. The applicant company therefore owned a set of proprietary rights – linked to its application for the registration of a trademark – that were recognized under Portuguese law,⁷⁴ even though they could be revoked under certain conditions.

74 The case concerned Portuguese law.

THE COURT OF LAW OF THE ANDINE COMMUNITY

Case No. 194-IP-2006

The Andine Community Rule protects the interest of the owner of the trademark, granting upon the owner the right of exclusive use of the distinctive sign while protecting the right of consumers to not be misled or confused in matters related to brand origin, quality, conditions, etc. of the products or services.

The trademark is defined as an immaterial good which allows for the identification or the distinction between differing products and services on the market.

9. *“Trademarks are something of an anomaly in intellectual property law”:*

MATTEL INC v 3894207 CANADA INC

2006 SCC 22 [Canada]

Unlike the patent owner or the copyright owner, the owner of a trademark is not required to provide the public with some novel benefit in exchange for the monopoly. The trademark owner, by contrast, may simply have used a common name as its “mark” to differentiate its wares from those of its competitors. Its claim to monopoly rests not on conferring a benefit on the public in the sense of patents or copyrights but on serving an important public interest in assuring consumers that they are buying from the source from whom they think they are buying and receiving the quality which they associate with that particular trade-mark. Trademarks thus operate as a kind of shortcut to get consumers to where they want to go, and in that way perform a key function in a market economy. Trademark law rests on principles of fair dealing. It is sometimes said to hold the balance between free competition and fair competition.

10. *Trademarks do not create monopolies nor does a trademark create a type of copyright:* Although the registration of trademarks gives rise to exclusive rights, they have no value or meaning *in vacuo*. Trademarks must be able to distinguish the goods or services of the trademark owner and this gives rise to the doctrine of functionality: trademarks may not be used to prevent the competitive use of utilitarian features of products, but only to perform a source-distinguishing function.

GLAXO GROUP LTD v DOWELHURST LTD

[2000] EWHC Ch 134 [UK]

Not infrequently courts, lawyers and clients refer to trademarks as creating monopolies or discuss them in terms which suggest that that is so. But trademark rights do not create monopolies in the true sense. Although trademarks give rise to exclusive rights as an indication of the source and quality of goods, it is only when relating to goods that they have life or value. A trademark is not a type of copyright. A proprietor does not obtain a monopoly in the mark as such.

Mere copying of a mark, for example by writing it down on a piece of paper, even in the course of business, does not *per se* infringe any trademark rights. The result is that the same or similar marks can be owned by different proprietors in respect of dissimilar goods or businesses. This is an everyday experience. The name LLOYDS is used as a mark by, amongst others, a pharmacy chain, a bank and an insurance market and the mark GRANADA has been used by unrelated companies in respect of motor cars and a television rental business.

A mark is always associated with particular goods [or services]. It is for this reason that there is an international classification of goods [and services] for trademark application purposes. It is also the reason why our Trademarks Act and the Community Trademark Regulation require trademark applications to be made in respect of specific goods and why the relationship between a registered mark and specific goods is inherent in the Council Directive which seeks to approximate trademark laws within the Community.

DRISTAN Trademark

[1986] RPC 161(SC) [India]

A trademark is meant to distinguish the goods made by one person from those made by another. A trademark therefore cannot exist *in vacuo*. It can only exist in connection with the goods in relation to which it is used or intended to be used. Its object is to indicate a connection in the course of trade between the goods and some person having the right to use the mark either with or without any indication of the identity of that person.

KIRKBI AG v RITVIK HOLDINGS INC

2005 SCC 65 [Canada]

The doctrine of functionality appears to be a logical principle of trademarks law. It reflects the purpose of a trademark, which is the protection of the distinctiveness of the product, not of a monopoly on the product. The Trademarks Act clearly recognizes that it does not protect the utilitarian features of a distinguishing guise. In this manner, it acknowledges the existence and relevance of a doctrine of long standing in the law of trademarks. This doctrine recognizes that trademarks law is not intended to prevent the competitive use of utilitarian features of products, but that it fulfills a source-distinguishing function. This doctrine of functionality goes to the essence of what is a trademark. In Canada, as in several other countries or regions of the world, this doctrine is a well-settled part of the law of trademarks. In the law of intellectual property, it prevents abuses of monopoly positions in respect of products and processes. Once, for example, patents have expired, it discourages attempts to bring them back in another guise.

MATTEL INC v 3894207 CANADA INC

2006 SCC 22 [Canada]

Fairness, of course, requires consideration of the interest of the public and other merchants and the benefits of open competition as well as the interest of the trademark owner in protecting its investment in the mark. Care must be taken not to create a zone of exclusivity and protection that overshoots the purpose of trademark law. The purpose of trademarks is to create and symbolize linkages.

11. *Abuse of trademark registrations:* The abuse of trademarks registers is not unknown; on the contrary, it is a common occurrence. Many trademark registrations are of doubtful value or validity and have proceeded to grant due to the lack of opposition because, at the time, no one had an interest in the particular trademark and because of the limited expertise of some trademark registries.

LUBBE NO v MILLENNIUM STYLE

[2007] ZASCA 10 [South Africa]

There are cyber-squatters and there are those who squat on the trademark register. Judged by the papers in this case the [plaintiff] is an entity that used the register to stifle competition and not for its statutory purpose. The fact that there is no opposition to an

application for registration or that there is not already something similar on the register does not mean that the application should proceed to grant. This practice gives intellectual property law a bad name. It also throws serious doubt on whether this part of the law covers anything intellectual.

12. *The right to use and exclude:* The registration of a trademark, if valid, gives to the registered proprietor of the trademark the exclusive right to the use of the trademark in relation to the goods or services in respect of which the trademark is registered. Some statutes, such as the Indian Act, state this explicitly; others do so by implication.

KIRKBI AG v RITVIK HOLDINGS INC

2005 SCC 65 [Canada]

Registration of a trademark gives the registrant the exclusive right to the use throughout Canada of the trademark and a right of action to remedy any infringement of that right. In addition, in order to exercise those rights, the existence of the mark itself does not have to be established. Registration is evidence enough. Nonetheless, marks remain marks, whether registered or unregistered, because their legal characteristics are the same.

DRISTAN Trademark

[1986] RPC 161(SC) [India]

The registration of a trademark confers very valuable rights upon the registered proprietor of that mark. Under s 27(1) of the 1958 Act, no person can institute any proceeding to prevent or to recover damages for, the infringement of an unregistered trademark. However, his right of action against any person for passing off goods as the goods of another person or the remedies in respect thereof is not affected by reason of the fact that his trademark is an unregistered one. Under s 28(1), the registration of a trademark, if valid, gives to the registered proprietor of the mark the exclusive right to the use of the mark in relation to the goods in respect of which it is registered and to obtain relief in respect of infringement of the mark in the manner provided by the Act.

At the same time a trademark right enables the owner to prevent others from using the mark as a trademark. It is often described as a negative right because (so the argument goes) the existence of the right does not necessarily mean that the owner has a right to use it at all times and under all conditions.

CAMPOMAR SOCIEDAD, LIMITADA v NIKE INTERNATIONAL LTD

[2000] HCA 12 [Australia]:

The nature of the “monopoly” conferred by provisions such as s 58(1) relevantly accords with that under the 1905 Act. The explanation given by Harvey CJ in *Leach v Wyatt* with respect to the 1905 Act is good for the 1955 Act. In that case, the Chief Judge in Equity rejected the proposition that the right given to the registered owner of a trademark affirmatively carried with it the right to use the mark anywhere in Australia at all times and under all conditions. His Honour went on to adopt the law stated with respect to earlier UK legislation by Buckley LJ in *Lyle and Kinahan Ltd*. Buckley LJ had pointed out that the only right conferred by registration was a right to prevent others from using the trademark as a mark for their goods.

13. *A trademark is to be used:* A trademark that is not used, or intended to be used, in respect of specified goods or services, may not be registered; if registered, and it is not used, it may lose its protection.⁷⁵ Art. 19 of the TRIPS Agreement provides in this regard as follows:

- If use is required [by national legislation] to maintain a registration, the registration may be cancelled only after an uninterrupted period of at least three years of non-use, unless valid reasons based on the existence of obstacles to such use are shown by the trademark owner. Circumstances arising independently of the will of the owner of the trademark which constitute an obstacle to the use of the trademark, such as import restrictions on or other government requirements for goods or services protected by the trademark, shall be recognized as valid reasons for non-use.
- When subject to the control of its owner, use of a trademark by another person [i.e. a licensee] shall be recognized as use of the trademark for the purpose of maintaining the registration.

MATTEL INC v 3894207 CANADA INC

2006 SCC 22 [Canada]

Unlike other forms of intellectual property, the gravamen of trademark entitlement is actual use. By contrast, a Canadian inventor is entitled to his or her patent even if no commercial use of it is made. A playwright retains copyright even if the play remains unperformed. But in trademarks the watchword is “use it or lose it”. In the absence of use, a registered mark can be expunged.

75 Use must be genuine use: *Silberquelle GmbH v Maselli-Strickmode GmbH* Case C-495/07 (ECJ).

DRISTAN Trademark

[1986] RPC 161(SC) [India]

As the definition of “trademark” shows, a trademark is a mark used or proposed to be used in relation to goods for the purpose of indicating or so as to indicate a connection in the course of trade between the goods and some person having the right to use the mark. It is, therefore, not necessary for the purpose of registering a trademark that those goods should be in existence at the date of the application for registration.

As the registration of a trademark confers such valuable rights upon its registered proprietor, a person cannot be permitted to register a trademark when he has not used it in relation to the goods in respect of which it is sought to be registered or does not intend to use it in relation to such goods.

HÖLTERHOFF v FREIESLEBEN

Case C-2/00 [ECJ]

The Advocate General reported:

“A trader registers or acquires a trademark primarily not in order to prevent others from using it but in order to use it himself (although exclusivity of use is of course a necessary corollary). Use by the proprietor is indeed a central and essential element of ownership [since] rights may lapse or be unenforceable in the event of non-use.”

14. Defensive trademarks: The requirement of use does not apply to defensive trademarks, which some legal systems recognize. Defensive trademarks are registered, not for the purpose of using them but in order to protect the reputation of a well-known trademark, which is registered in another class. They have lost their importance because, in terms of the TRIPS Agreement, trademarks with a reputation (well-known trademarks) are entitled to wider protection than simply against use in relation to the specified goods or services for which they are registered.

15. Territoriality: A trademark right is territorial. It is only effective within the territory where it is registered or, if not registered, well known. Community trademarks are also only effective within the territory of the European Union.

PERSON'S CO LTD v CHRISTMAN

900 F2d 1565 (Fed Cir 1990) [USA]

The concept of territoriality is basic to trademark law; trademark rights exist in each country solely according to that country's statutory scheme.

VICTORIA'S SECRETS INC v EDGARS STORES LTD1994 (3) SA 739 (A) [South Africa]⁷⁶

The *Moorgate* judgment stated that

"a trademark is purely a territorial concept; it is legally operative or effective only within the territory in which it is used and for which it is to be registered. Hence, the proprietorship, actual use, or proposed use of a trademark mentioned in [the Trademarks Act], are all premised by the subsection to be within the [Republic of South Africa]."

It follows that the fact that a trademark is registered and has been used, even extensively used, by one person in a foreign country does not in itself constitute a bar to its adoption and registration by some other person in South Africa. In the case of a foreign trademark, there is no legal bar to its adoption in South Africa unless it is attended by something more:

"The basis of the challenge on this ground is that the objector was to the knowledge of the applicant the proprietor of such a trademark in [the foreign country] and that the applicant improperly appropriated the mark. In the present state of the law a trademark is a purely territorial concept and there is, generally speaking, nothing to prevent a person from asserting a proprietary right in a trademark in relation to which no one else has in the same territory asserted a similar right."

BARCELONA.COM INC v EXCELENTISIMO AYUNTAMIENTO DE BARCELONA

189 F Supp 2d 367 (ED Va 2002) [USA]

By requiring application of United States trademark law to this action brought in a United States court by a United States corporation involving a domain name administered by a United States registrar, [the Act] is consistent with the fundamental doctrine of territoriality

76 Quoted in *AM Moolla Group Ltd v Gap Inc* [2005] ZASCA 72 [South Africa].

upon which our trademark law is presently based. Both the United States and Spain have long adhered to the Paris Convention for the Protection of Industrial Property. Section 44 of the Lanham Act incorporates the Paris Convention into United States law, but only “to provide foreign nationals with rights under United States law which are coextensive with the substantive provisions of the treaty involved.”

The relevant substantive provision in this case is Art. 6(3) of the Paris Convention, which implements the doctrine of territoriality by providing that “[a] mark duly registered in a country of the [Paris] Union shall be regarded as independent of marks registered in the other countries of the Union, including the country of origin.” As one distinguished commentary explains,

“the Paris Convention creates nothing that even remotely resembles a “world mark” or an “international registration”. Rather, it recognizes the principle of the territoriality of trademarks [in the sense that] a mark exists only under the laws of each sovereign nation.”⁷⁷

It follows from incorporation of the doctrine of territoriality into United States law that United States courts do not entertain actions seeking to enforce trademark rights that exist only under foreign law.

The principle of territoriality applies also to Internet trade as appears from the following dictum. The reference to a “third State” is a reference to a country that is not a Member of the EU. In another context the reference would have been to a foreign country.

L'ORÉAL SA v eBAY INTERNATIONAL AG

ECJ, 12 July 2011, Case C-324/09

Where goods located in a third State, which bear a trade mark registered in a Member State of the EU or a Community trade mark and have not previously been put on the market in the EEA or, in the case of a Community trade mark, in the EU, (i) are sold by an economic operator through an online marketplace without the consent of the trade mark proprietor to a consumer located in the territory covered by the trade mark or (ii) are offered for sale or advertised on such a marketplace targeted at consumers located in that territory, the trade mark proprietor may prevent that sale, offer for sale or advertising by virtue of the rules set out in Article 5 of Directive.

⁷⁷ Quoting J. Thomas McCarthy *McCarthy on Trademarks and Unfair Competition* §29:25 (4 ed 2002).

It is the task of the national courts to assess on a case-by-case basis whether relevant factors exist, on the basis of which it may be concluded that an offer for sale or an advertisement displayed on an online marketplace accessible from the territory covered by the trade mark is targeted at consumers in that territory.

C. THE FUNCTION OF TRADEMARKS

16. *A trademark is a badge of origin and must be distinctive:* The primary function of a trademark is that of a badge of origin. In assessing infringement, regard must be had to this function, namely, to distinguish the goods or services of the trademark owner from those of others. The main question then is whether the use of the infringing mark impacts on this “badge of origin” function of the senior mark.

WING JOO LOONG GINSENG HONG (SINGAPORE) CO PTE LTD v QINGHAI XINYUAN FOREIGN TRADE CO LTD

[2009] SGCA 9 [Singapore]

The cornerstone of a mark or sign which has been registered as a trade mark is its capacity to distinguish, i.e., its ability to distinguish the goods or services of a particular supplier so as to serve as a badge of trade origin to the average consumer who encounters the mark. As stated in *Executrices of the Estate of Diana, Princess of Wales’ Application* [2001] ETMR 25,

“it is clear that the ability to distinguish the goods or services of one undertaking from those of other undertakings remains the essential function of a trade mark”).

It is for this reason that a mark or sign has to have a certain level of distinctiveness before it can be registered as a trade mark. According to the learned author of Ng-Loy’s *Intellectual Property*, there are three thresholds of distinctiveness *vis-à-vis* trademarks, as follows:

“The interplay between the three thresholds of distinctiveness is as follows. The **first threshold** is found in the statutory definition of ‘trade mark’ itself: a sign must be *capable* of distinguishing goods or services dealt with or provided in the course of trade by a person from goods or services so dealt with by any other person. A sign which fails to cross this capacity-to-distinguish threshold is not a trade mark for the purposes of the Trade Marks Act, and s 7(1)(a) prohibits its registration.

The **second threshold** is found in ss 7(1)(b)–(d) which prohibit the registration of trademarks which are devoid of distinctive character, for example, trademarks which are descriptive of the goods or services for which registration is sought. Such trademarks are the ones which lack inherent distinctiveness, and as indicated above, they are *prima facie* not allowed registration.

If the applicant of an inherently non-distinctive trade mark shows that it has crossed the **third threshold** of distinctiveness set out in s 7(2), that is, the mark has acquired sufficient *de facto* distinctiveness as a result of the applicant's use ... of the mark before the date of the application, the mark will be accepted for registration."

YALE ELECTRIC CORPORATION v ROBERTSON

26 F 2d 972 (1928) [USA]

The law of unfair trade comes down very nearly to this - as judges have repeated again and again - that one merchant shall not divert customers from another by representing what he sells as emanating from the second. This has been, and perhaps even more now is, the whole Law and the Prophets on the subject, though it assumes many guises.

His mark is his authentic seal; by it he vouches for the goods which bear it; it carries his name for good or ill. If another uses it, he borrows the owner's reputation, whose quality no longer lies within his own control. This is an injury, even though the borrower does not tarnish it, or divert any sales by its use; for a reputation, like a face, is the symbol of its possessor and creator, and another can use it only as a mask. And so it has come to be recognized that, unless the borrower's use is so foreign to the owner's as to insure against any identification of the two, it is unlawful.

CANON KABUSHIKI KAISHA v METRO-GOLDWYN-MAYER INC

ECJ, 29 September 1998, C-39/97, ECR 1998, I-5507

The essential function of the trademark is to guarantee the identity of the origin of the marked product to the consumer or end user by enabling him, without any possibility of confusion, to distinguish the product or service from others which have another origin. For the trademark to be able to fulfill its essential role in the system of undistorted competition, it must offer a guarantee that all the goods or services bearing it have originated under the control of a single undertaking which is responsible for their quality.

GLAXO GROUP LTD v DOWELHURST LTD

[2000] EWHC Ch 134 [UK]

A trademark is a badge, in the widest sense, used on or in relation to goods so as to indicate source. That is to say it is meant to indicate that goods are goods of the proprietor. In some cases this will mean that they are the goods of a particular manufacturer, as would be the case with RENAULT for cars, CADBURY for chocolates and AGFA for photographic equipment. Sometimes it will mean that they are goods selected by or distributed through a particular intermediary as would be the case with MARKS & SPENCER for own-brand food, flowers etc, LITTLEWOODS for mail order clothes etc and AMAZON for books bought over the internet.

Furthermore, where goods have passed through a number of hands, the marks of more than one proprietor may be found on, or be used in relation to, the goods. Someone who buys a book over the internet will probably receive it in a box and with a delivery note, each of which bears the mark of the retailer while the book itself will bear the mark of the publisher. Similarly someone who purchases a product in a large department store will receive it in a bag bearing the store's trademark. In some stores goods are priced with sticky labels bearing the name of the store, so that goods bear both the manufacturer's and the retailer's marks. Sometimes marks are anonymous. For example the marks BEEFEATER for gin and JIF, DAZ and OMO for cleaning materials are not the names of the companies which make those products.

In some cases the customer will realize from surrounding circumstances that a mark identifies the source as a manufacturer or as a retailer. RENAULT falls into the former category while MARKS & SPENCER falls into the latter. Sometimes it will not be clear in what capacity a mark identifies source. For example the well-known department store, Harrods, has many products which bear its trademark HARRODS. However it also has its own bakery. The mark HARRODS when used on or in relation to many of its breads and cakes is the mark of the manufacturer as well as the retailer. This reflects not only legal theory but the real world. A customer who is supplied with defective goods may complain to the retailer/distributor or the manufacturer, if different, or both. It may well be immaterial to him whether the mark is that of the distributor or the manufacturer, all that matters is that it is from a particular source. This variety of ways in which marks are used by proprietors and understood by customers does not undermine or detract from their value or function.

BREAKFAST -DRINK II

Federal Supreme Court (BGH), ruling of December 20, 2001 - I ZR 135/99 [Germany]:

According to European Court of Justice (ECJ) case law, the key to answering the question is whether the designation under discussion distinguishes the goods or services as originating from a particular company – that is, whether it is used as a mark – or whether the use is for other purposes.

Thus, the Court has not considered every commercial use of an indication to constitute a mark; it has placed the emphasis on the distinguishing function of the mark.

Use as a mark in the aforementioned sense of an act of infringement thus requires that the use serves also to distinguish the products/services of one company from those of others, at least in the area of product/service sales.

However, in this case, the use of the designation “breakfast drink” (which is the only contested designation) does not constitute use as a mark. In its contrary judgment the *Land* Court neglected to note, despite the respondent’s express reference to this point, that the designation was not a distinctive combination of words that would be understood in everyday speech to indicate the origin of the product it described, but rather a descriptive indication in the sense of a definition, which would be understood in common parlance – that is, by an average consumer with average awareness, attention and understanding for it is such a person’s understanding that is the key – as meaning only a drink consumed at breakfast rather than as an indication of origin: everyday experience shows the extreme unlikelihood that the average consumer would infer an indication of origin from a descriptive term such as the contested designation, and the *Land* Court failed to establish any grounds to indicate otherwise.

THE COURT OF LAW OF THE ANDINE COMMUNITY

File 15-IP-2003. Court interpretation of 12 March 2003:

The true and only essential function of the trademark is to distinguish one product or service from others. Although knowing the identity of the manufacturer of the product is essential to many people when they make a choice for a certain product, this piece of information can be found outside the distinguishing trademark. The trademark allows for a distinction to be made between products or services from the same field. If a certain sign is not able to distinguish a

product or service from the others, then it cannot be a trademark as we understand the term.

The trademark also has the function to indicate the origin of goods and to act as a guarantee; based on the former, the trademark gives the consumer the possibility to grant an origin to the product, while the latter guarantees to the consumer that all the products bearing the same brand are of the same quality, which means that by buying the same product or requesting the same service, the consumer wishes to encounter the same quality or even better quality than that of the previously acquired product or service.

Finally, the trademark has a publicity function, through which the owner of the trademark promotes the product identified through it.

17. Importance of the badge of origin concept:

MISHAWAKA RUBBER & WOOLEN MANUFACTURING CO v SS KRESGE Co

316 US 203 (1942) [USA]

The protection of trademarks is the law's recognition of the psychological function of symbols. A trademark is a merchandising short-cut which induces a purchaser to select what he wants, or what he has been led to believe he wants. The owner of a mark exploits this human propensity by making every effort to impregnate the atmosphere of the market with the drawing power of a congenial symbol. Whatever the means employed, the aim is the same – to convey through the mark, in the minds of potential customers, the desirability of the commodity upon which it appears. Once this is attained, the trademark owner has something of value.

18. Trademarks protect enterprises big and small:

LAUGH IT OFF PROMOTIONS CC v SAB INTERNATIONAL (FINANCE) BV

[2005] ZACC 7 [South Africa]

[After quoting the preceding reference said:] From the producer's side, trademarks promote invention, protect investment and enhance market-share by securely identifying a product or service. From the consumer's point of view, they facilitate choice by identifying the product and guaranteeing its provenance and presumed quality. Furthermore, although this case has been presented as a David and Goliath contest, it is not only the Goliaths of this world who need trademark protection. Small entrepreneurs

fighting to increase their share of the market against the Goliaths strive energetically to identify their uniqueness and that of their products and services. Confusion, dilution or tarnishing of their trademarks can be as harmful to them as to any of the major companies, indeed more so, because their capacity to mitigate any detriment will be attenuated.

19. Quality and advertising: Trademarks, in addition to the badge of origin function, also serve an advertising function, and provide a certain guarantee of quality. The dilution of registered trademarks with a reputation by blurring or tarnishing is therefore considered in some systems to amount to trademark infringement.

A trademark must offer a guarantee that all the goods bearing it have originated under the control of a single undertaking which is responsible for their quality. It does not, however, provide a legal guarantee of quality but trademark owners know that consumers rely on the fact that they have an economic interest in maintaining the value of their marks. Trademarks, accordingly, provide a commercial guarantee of quality.

SCANDECOR DEVELOPMENTS AB v SCANDECOR MARKETING AB

2001 UKHL 21 [UK]

Although the use of trademarks is founded on customers' concern about the quality of goods on offer, a trademark does not itself amount to a representation of quality. Rather it indicates that the goods are of the standard which the proprietor is content to distribute "under his banner". The concept of the owner of a mark holding himself out as responsible for the quality of the goods sold under his mark was noted by Lord Wright:

"The word *origin* is no doubt used in a special and almost technical sense in this connection, but it denotes at least that the goods are issued as vendible goods under the aegis of the proprietor of the trademark, who thus assumes responsibility for them, even though the responsibility is limited to selection, like that of the salesman of carrots on. By putting them on the market under his trademark he vouched his responsibility."

Thus, in relying on a trademark, consumers rely, not on any legal guarantee of quality, but on the proprietor of a trademark having an economic interest in maintaining the value of his mark. It is normally contrary to a proprietor's self-interest to allow the quality of the goods sold under his banner to decline.

20. *The relationship between badge of origin and distinctiveness:*

SCANDECOR DEVELOPMENTS AB v SCANDECOR MARKETING AB

2001 UKHL 21 [UK]

A trademark is a badge of origin or source. The function of a trademark is to distinguish goods having one business source from goods having a different business source. It must be “distinctive”. That is to say, it must be recognizable by a buyer of goods to which it has been affixed as indicating that they are of the same origin as other goods which bear the mark and whose quality has engendered goodwill.

This fundamental proposition still remains true. The ECJ described the essential function of a trademark as giving to the consumer or ultimate user “a guarantee of the identity of the origin of the marked product by enabling him to distinguish, without any possible confusion, that product from others of a different provenance.” For a trademark to perform this function, it must offer a guarantee that all the goods bearing it have originated under the control of a single undertaking which is responsible for their quality.

The need to distinguish the business source of goods is as old as trading itself. A maker of goods seeks to acquire and maintain a reputation for the quality of his goods, thereby encouraging customers to prefer his goods to those of his competitors. So he places a recognizable mark on his goods to distinguish them from the goods of others. It is in the public interest that he should be able to do so, and that he should be able to prevent others from using his chosen mark. The ability to apply a mark to goods encourages makers of goods to set and maintain quality standards. It enables customers to make an informed choice between different goods available in the market.

21. *Application of the badge of origin concept:* The German Federal Court held that the use of a Ferrari car as a prize in an advertisement for liquor did not infringe the Ferrari trademark.

FERRARI v JÄGERMEISTER AG

BGH, ruling of November 3, 2005 - I ZR 29/03 [Germany]

There is no justification for the trademark owner to oppose the awarding of branded goods bearing the competition sponsor's sign as prizes if the placing of the sign next to the trademark is clearly only an indication of the sponsorship and does not create the impression of there being a commercial relationship between sponsor and trademark owner.

The advertising effect of making the company look generous by promising a luxury product as a prize is a natural consequence of this particular competition. The fact that the prize on offer is a well-known make of luxury car does not push this transfer effect onto the wrong side of the legal line. [Translated.]

A South African court reached the same conclusion where a company, which marketed a car polish, used as part of its advertising campaign a photo showing the use of the polish on a BMW car. The photo showed the BMW logo prominently. BMW alleged, unsuccessfully, that this amounted to trademark infringement considering that BMW had trademarks for the logo in respect of both cars and car polish.

VERIMARK (PTY) LTD v BMW AG

[2007] ZASCA 53 [South Africa]

It is trite that a trademark serves as a badge of origin and that trademark law does not give copyright-like protection. Section 34(1)(a), which deals with primary infringement and gives in a sense absolute protection, can, therefore, not be interpreted to give greater protection than that which is necessary for attaining the purpose of a trademark registration, namely protecting the mark as a badge of origin. In *Anheuser-Busch*⁷⁸ the ECJ was asked to determine the conditions under which the proprietor of a trademark has an exclusive right to prevent a third party from using his trademark without his consent under a primary infringement provision. The ECJ affirmed that

“the exclusive right conferred by a trademark was intended to enable the trademark proprietor to protect his specific interests as proprietor, that is, to ensure that the trademark can fulfill its functions and that, therefore, the exercise of that right must be

78 ECJ, 16 November 2004, *Anheuser-Busch / Budjovický Budvar*, C-245/02, ECR 2004, I-10989.

reserved to cases in which a third party's use of the sign affects or is liable to affect the functions of the trademark, in particular its essential function of guaranteeing to consumers the origin of the goods."

That is the case, the ECJ said, where the use of the mark is such that it creates the impression that there is a "*material link* in trade between the third party's goods and the undertaking from which those goods originate". There can only be primary trademark infringement if it is established that consumers are likely to interpret the mark, *as it is used by the third party*, as designating or tending to designate the undertaking from which the third party's goods originate.

22. *A trademark is also a creative silent salesman because it guarantees quality:* Provisions which provide special protection to well-known trademarks are not concerned with the protection of origin or against confusion. They protect the economic value of a trademark, more particularly its reputation and its advertising value or selling power. As summed up by Tony Martino:⁷⁹

"A trademark is a 'creative silent salesman' stimulating sales by creating goodwill and assuring buyers that all goods bearing the same mark have the same quality. 'The mark actually sells the goods; the more distinctive the mark, the greater its selling power'."

L'ORÉAL SA v BELLURE NV

ECJ, 18 June 2009, C-487/07, ECR 2009, I-5185

The exclusive right under Article 5(1)(a) of Directive 89/104 was conferred in order to enable the trade mark proprietor to protect his specific interests as proprietor, that is, to ensure that the trade mark can fulfil its functions and that, therefore, the exercise of that right must be reserved to cases in which a third party's use of the sign affects or is liable to affect the functions of the trade mark. These functions include not only the essential function of the trade mark, which is to guarantee to consumers the origin of the goods or services, but also its other functions, in particular that of guaranteeing the quality of the goods or services in question and those of communication, investment or advertising.

D. THE ESSENTIALS OF TRADEMARKS

23. *The subject-matter of trademarks:* The TRIPS Agreement (Art. 15.1) defines the protectable subject matter of trademarks in these terms:

Any sign, or any combination of signs, capable of distinguishing the goods or services of one undertaking from those of other undertakings, shall be capable of constituting a trademark.

Such signs, in particular words including personal names, letters, numerals, figurative elements and combinations of colours as well as any combination of such signs, shall be eligible for registration as trademarks.

Where signs are not inherently capable of distinguishing the relevant goods or services, Members may make registrability depend on distinctiveness acquired through use. Members may require, as a condition of registration, that signs be visually perceptible.

24. *Essentials of trademarks:* It follows from this that a trademark:

- Must consist of a “sign” or combination of “signs” (usually something that can be represented graphically), and
- Must be capable of distinguishing in the sense described. The capability to distinguish can either be
 - inherent in the mark, or
 - acquired through use.

This is illustrated by the Indian definition of a trademark: it is a mark capable of being represented graphically and which is capable of distinguishing the goods or services of one person from those of others and it may include the shape of goods, their packaging and combination of colors. A mark, in turn, includes a device, brand, heading, label, ticket, name, signature, word, letter, numeral, shape of goods, packaging or combination of colors or any combination thereof.

DYSON LTD v REGISTRAR OF TRADEMARKS

ECJ, 25 January 2007, C-321/03, ECR 2007, I-687

It follows that, to be capable of constituting a trademark, the subject-matter of any application must satisfy three conditions. First, it must be a sign. Secondly, that sign must be capable of being represented graphically. Thirdly, the sign must be capable of distinguishing the goods or services of one undertaking from those of other undertakings.

25. *Perceptibility*: A trademark must be perceptible by one of the senses.

THE COURT OF LAW OF THE ANDINE COMMUNITY

Case No 194-IP-2006

A trademark is an immaterial good and, in order to be understood or perceived by one of the senses, it must be externalized or given material form through the use of each type of element which transforms immaterial or abstract concepts in something which is perceivable or identifiable through one of the senses.

Only a perceptible sign is apt to constitute a trademark, by leaving to an observer an image or impression which causes the distinction or identification of a certain product.

A sign, in order to be allowed to be registered as a trademark, must be capable of being represented by words, charts, signs, colors, figures, etc. so that its components can be appreciated by external observers. This is an important feature for the publication of registration requests in the official publications.

26. *Types of trademarks*: There are different types of trademarks. What is or is not registrable as a trademark depends on the definition of the term in the relevant national statute. Typical are devices or logos, names (such as FORD), words (like APPLE), letters (e.g. BMW), numerals (4711), slogans and shapes, configurations, patterns, ornamentations, colors or containers for goods (the Coca-Cola bottle). Some jurisdictions allow the registration of anything that can serve to distinguish, even musical tunes (for instance, mobile phone ring tunes) or fragrances for perfumes.

American theory on trademark law divides trademarks into four categories: fanciful marks, arbitrary marks, suggestive marks and descriptive marks.⁸⁰

WAL-MART STORES INC v SAMARA BROTHERS INC

529 US 205 (2000) [USA]

In evaluating the distinctiveness of a mark courts have held that a mark can be distinctive in one of two ways. First, a mark is inherently distinctive if “[its] intrinsic nature serves to identify a particular source.” In the context of word marks, courts have applied the now-classic test originally formulated by Judge Friendly, in which word marks that are “arbitrary” (“Camel” cigarettes), “fanciful”

80 Huang Hui *Effects of Distinctiveness of Trademarks on their Registration and Protection*: www.cpahk ltd.com/Publications/Article/Ehh992.html. On descriptive marks see ECJ, 25 February 2010, *Lancôme / OHIM*, C-408/08 P, ECR 2010, I-1347.

(“Kodak” film), or “suggestive” (“Tide” laundry detergent) are held to be inherently distinctive. Second, a mark has acquired distinctiveness, even if it is not inherently distinctive, if it has developed secondary meaning, which occurs when, “in the minds of the public, the primary significance of a [mark] is to identify the source of the product rather than the product itself.”

PLAYBOY ENTERPRISES INC v BHARAT MALIK

2001 PTC 328 [India]

Trademarks are mainly of four varieties. The name of the trademark may be “generic”, which means that it may refer to the genus of which the particular product may be a species. It may be “descriptive”, which means that it may describe the nature or type of goods to which they are applied. It may be “suggestive”, which involves imagination, thought and perception to reach a conclusion to the nature of the goods. It may be “arbitrary” or fanciful, which does not have any connection to the nature or type of the goods.

THE COURT OF LAW OF THE CARTAGENA AGREEMENT

Quito, 3 December 1987

Trial No 1-IP-87

A trademark, according to the nature or structure of the sign used therein, can be denominative, graphical or mixed. The denominative trademark – important for this case – is made up of several letters making up a pronounceable whole, with or without actual meaning. There are also graphical trademarks (visual signs), mixed trademarks (graphical and denominative) and so-called “tri-dimensional” trademarks, such as the package trademark.

27. *Factual issue:* The question whether a mark constitutes a trademark as defined is a factual matter and should be approached without any *a priori* disqualification or classification. Older statutes often listed the kind of marks that were not capable of being registered, such as names of persons or localities, or laudatory words. The tendency is to move away from this approach which is in any event incompatible with the TRIPS Agreement.

DAVID WEST v FULLER SMITH & TURNER PLC

[2003] EWCA Civ 48 [UK]

To a much greater degree, this case illustrates the break with our domestic past brought about by the 1994 Act. The words, for which the first two initials stand, are merely laudatory words, the

mark consists purely of initials and the words connoted by the initials are mere descriptors. This concatenation of features would have made it difficult for this mark to survive the present attack under our pre-1994 Act domestic law. If King Canute had been a trademark agent, the waters of Community law, which Lord Denning depicted as rushing up our native shores, would surely have overwhelmed him by now.⁸¹ As the respondent submits, one has to start by forgetting the preconceptions of pre-1994 Act trademark law. The territory that can be occupied by registered trademarks has been significantly enlarged by the 1994 Act, and traders who use such marks without consent must increasingly rely on the limits as to the effect of a registered trademark, set out in s 11 of the 1994 Act.

The recognition of the ability of unconventional trademarks to perform a trademark function, i.e., to act as a badge of origin, is of fairly recent date. As late as 1986, the UK House of Lords⁸² regarded the idea that the shape of a bottle – in that case the classic Coca-Cola bottle – could be a trademark as startling in spite of the fact that some countries had already accepted that they could be. Once recognized, these trademarks do not differ from any other kind of trademark from a legal perspective:⁸³

The criteria for assessing the distinctive character of three-dimensional shape-of-products marks are no different from those applicable to other categories of trademark.

E. WHAT IS NOT A TRADEMARK?

28. *A mark is something distinct from the goods or services themselves.*

KONINKLIJKE PHILIPS ELECTRONICS NV v REMINGTON PRODUCTS PTY LTD

[2000] FCA 876 [Australia]

The facts: Philips held a registered trademark in the three-headed rotary shaver. Remington made a similar shaver and the question was whether this amounted to an infringement of the Philips mark. The Court held that it did not. According to other courts the trademark registration would have been invalid.⁸⁴

81 According to legend, King Canute rebuked his flattering courtiers by showing that the sea would not retreat at his command.

82 *Coca-Cola Trademarks* [1986] RPC 421 (HL).

83 ECJ, 29 April 2004, *Henkel / OHIM*, joined cases C-456/01 P and C-457/01 P, ECR 2004. I-5089.

84 ECJ, 18 June 2002, *Philips / Remington*, C-299/99, ECR 2002, I-5475.

In my opinion, merely to produce and deal in goods having the shape, being a functional shape, of something depicted by a trademark (here the marks do depict, one more completely than the other, a working part of a triple rotary shaver) is not to engage in a “use” of the mark “upon, or in physical or other relation to, the goods” within s 7(4), or to “use” it “in relation to the goods” within s 20(1) [of the Australian Act]. “Use” [the noun] and “use” [the verb], in those contexts, convey the idea of employing the mark, (first) as something that can be “upon” or serve in a “relation” to the goods, (and secondly) so as to fulfill a purpose, being the purpose of conveying information about their commercial origin. The mark is added, as something distinct from the goods. It may be closely bound up with the goods, as when it is written upon them, or stamped into them, or moulded onto them, or, in the case of a liquid, it may be sold in a container so formed as to constitute at once both container and mark. But in none of these cases is the mark devoid of a separate identity from that of the goods. The alternative ways of using a trademark in relation to goods do not include simply using the goods themselves as the trademark. The reason is plain: it is to be assumed that goods in the market are useful, and if they are useful, other traders may legitimately wish to produce similar goods (unless, of course, there are, for the time being, subsisting patent, design or other rights to prevent them from doing so), and it follows that a mark consisting of nothing more than the goods themselves could not distinguish their commercial origin, which is the function of a mark. As Jacob J said of a “picture mark”:

“A picture of an article is equivalent to a description of it – both convey information. If the picture is simply of an artifact which traders might legitimately wish to manufacture then to my mind it is just like the common word for it and, like the word for it, incapable of distinguishing.”

Even if such a mark achieves registration, that does not make the manufacture and sale of similar artifacts into a use of the mark as a trademark.

29. Prohibited trademarks: Trademark laws usually contain a list of signs that may not be registered as trademarks.⁸⁵ The UK Act has the following list, which is fairly comprehensive, of prohibited marks:

85 A number of these grounds were discussed in detail in *Wing Joo Loong Ginseng Hong (Singapore) Co Pte Ltd v Qinghai Xinyuan Foreign Trade Co Ltd* [2009] SGCA 9.

- Signs which do not satisfy the requirements of a “trademark”, i.e., signs incapable of being represented graphically and not capable of distinguishing goods or services of one undertaking from those of other undertakings,
- Trademarks that are devoid of any distinctive character,
- Trademarks that consist exclusively of signs or indications which may serve, in trade, to designate the kind, quality, quantity, intended purpose, value, geographical origin, the time of production of goods or of rendering of services, or other characteristics of goods or services,
- Trademarks that consist exclusively of signs or indications which have become customary in the current language or in the *bona fide* and established practices of the trade.

In addition, a sign may not be registered as a trademark if it consists exclusively of the shape:

- which results from the nature of the goods themselves,
- of goods which is necessary to obtain a technical result, or
- which gives substantial value to the goods.

This prohibition, which incorporates the doctrine of functionality, is discussed later. Furthermore, a trademark may not be registered if:

- it is contrary to public policy or to accepted principles of morality,⁸⁶
- it is of such a nature as to deceive the public (for instance as to the nature, quality or geographical origin of the goods or service),
- its use is prohibited by any enactment or rule of law,
- or to the extent that the application is made in bad faith.

30. Descriptive usage: Much of this is simply an application of the general rule that something that describes the goods or services concerned cannot distinguish them for trademark purposes. One could, accordingly, not have the trademark “Apple” for apples but it is a perfect trademark for computers.⁸⁷

CANADIAN SHREDDED WHEAT CO LTD v KELLOGG CO OF CANADA LTD

(1938) 55 RPC 125 (PC)

A word or words to be really distinctive of a person’s goods [or services] must generally speaking be incapable of application to the goods [or services] of anyone else.

⁸⁶ General Court, 5 October 2011, *PAKI Logistics / OHIM (PAKI)*, T-526/09.

⁸⁷ The representation of a green apple was held to be distinctive for goods and services of a dentist: Case 30 W [pat] 106/09 – Grüner Apfel – 9 Sept 2010 (German Federal Patent Court).

The more a trademark is descriptive of the goods or services, the less likely it will be capable of distinguishing them in this sense. If a trademark is primarily descriptive, it requires “sufficient capricious alteration” to be able to perform a trademark function.

The fact that a trademark, by use, has become such as to denote goods or services of a particular origin, does not necessarily mean that it is capable of distinguishing those goods or services in the trademark sense. In particular, the shape of a product, which gives substantial value to that product, cannot constitute a trademark even where, prior to the application for registration, it acquired attractiveness as a result of its recognition as a distinctive sign following advertising campaigns presenting the specific characteristics of the product in question.⁸⁸

31. An example – geographical indications: In order to illustrate the application of these limitations, use will be made of a judgment dealing with the prohibition of trademarks that consist exclusively of signs or indications which may serve, in trade, to designate the geographical origin of goods or of rendering of services. The question was whether the name of a property development consisting of residential and business sites could be a trademark since it had become a geographical indication.

CENTURY CITY APARTMENTS v CENTURY CITY PROPERTY OWNERS

[2009] ZASCA 157 [South Africa]

It follows from this historical analysis that reliance on English or Australian cases dealing with the validity of a trade mark consisting of a word which is according to its ordinary signification a geographical name are of little if any value in interpreting our statutes. As I have stated before in the context of laudatory marks,

“Intellectual property laws and principles are not locked in a time capsule or a straitjacket and judicial expositions should be read in context.”

A major shift in the approach to trademarks followed the adoption of the European Union’s Directive on trademarks during 1988. The United Kingdom was obliged to bring its laws into conformity with the Directive and did so by the passing of the Trademarks Act of 1994. Our law is now in many respects the same as that of the UK and of the European Community.

88 ECJ, 20 September 2007, *Benetton Group / G-Star International*, C-371/06, ECR 2007, I-7709.

Against this background I proceed to consider the question as to when a mark consists exclusively of a sign or an indication which may serve, in trade, to designate the geographical origin of the services. It should be noted that this provision does not deal with what are called geographical indications such as Champagne which connotes a sparkling wine with a particular geographical origin.

[The Act] prohibits the registration of geographical names as trademarks “solely where they designate specified geographical locations which are already famous, or are known for the category of goods or services concerned, and which are therefore associated with those goods in the mind of the relevant class of persons”. It also prohibits registration of geographical names that are likely to be used by undertakings. They ought to remain available as indications of the geographical origin of the category of relevant goods or services (*Peek & Cloppenburg KG’s Application* [2006] ETMR 33 para 34).

[The section] must be read in context. It also deals on the same basis with marks that may designate the kind, quality, quantity, intended purpose, value, or other characteristics of the goods or services. It is not concerned with distinctiveness or its loss. That is dealt with in [another provision]. The prohibition is not directed at protecting trademark use only but goes wider: it is sufficient if the name may “designate” the geographical origin of the goods or services.

It has been said that the provision serves a public interest permitting all to use such descriptive signs freely by preventing them from being reserved to one undertaking alone because they have been registered as trade marks (*Peek & Cloppenburg* para 32). In addition

“it is in the public interest that they [the geographical names] remain available, not least because they may be an indication of the quality and other characteristics of the categories of goods concerned, and may also, in various ways, influence consumer tastes by, for instance, associating the goods with a place that may give rise to a favourable response.”

Counsel debated the meaning of “exclusively” in the context of the provision but there can be little doubt that it means that the prohibition is directed at a mark that consists of a geographical name without more. A device that includes a geographical name would not be hit nor would a name mark consisting of a geographical name with something more be covered. What this means is that

Gordon's London Gin would be a permissible trade mark but not "London" in respect of gin.

This leads to another aspect and that concerns the nature of the goods or services. London has at least since the 18th Century had an association with gin. But Bloemfontein does not have one and there appears to be no reason why the name Bloemfontein *per se* cannot be used as a trade mark for gin in the same way as Windhoek, a well-known trade mark and the capital of Namibia, is used as a trade mark for beer. The explanation is to be found in *Bellagio LLC's Application* [2006] ETMR 79. The applicant sought to register the trade mark "Bellagio" in four different classes namely class 25 for clothing; class 35 for retail services; class 41 for entertainment services; and class 42 for hotels and the like. The application was granted in respect of the first two classes but refused in relation to the last two. The reasons, in summary, were these: Bellagio is a village on Lake Como in Northern Italy; it is a noted lakeside resort; the travelling public would associate the name of the village with entertainment and hotels; and therefore the mark could not be registered in connection with these services. However, the public would not necessarily associate the village with clothing or retail services and in connection with those services the prohibition did not apply.

In *Peek & Cloppenburg* the applicant sought to register the name Cloppenburg in respect of retail services. Cloppenburg is a small town in Germany and the application for registration was refused in the first instance on the ground that the applicant's services would have been supplied from that town, and to that end users would have perceived the town name as an indication of geographical origin. The court upheld the appeal, holding that a sign's descriptiveness cannot be assessed other than by reference to the goods or services concerned, on the one hand, and by reference to the understanding which the relevant persons have of it, on the other. It said:

"In making that assessment the [Trademark] Office is bound to establish that the geographical name is known to the relevant class of persons as the designation of a place. What is more, the name in question must suggest a current association, in the mind of the relevant class of persons, with the category of goods or services in question, or else it must be reasonable to assume that such a name may, in the view of those persons, designate the geographical origin of that category of goods or services."

F. THE DOCTRINE OF FUNCTIONALITY

32. *A trademark must be a source identifier.*⁸⁹ According to public perception containers and shapes⁹⁰ generally do not, in US parlance, serve as source identifiers.⁹¹ Containers are usually perceived to be functional and, if not run of the mill, to be decorative and not badges of origin. This means that although a three-dimensional object can perform a trademark function, the law frowns on granting trademark rights in relation to products themselves. For instance, the shape of a Lego block tends to identify the origin of the block but should it be entitled to trademark protection?⁹² Or the shape of a pharmaceutical tablet?⁹³ Or the shape of a razor head? Or a wine bottle?⁹⁴ Or the shape of a shoe sole?⁹⁵ The general answer is in the negative.

“Both the common law of passing off and the [Canadian] Trade-Marks Act contemplate that a product’s distinctive shape, appearance or packaging can take on the role of a trademark. Yet it is also understood that the protection afforded under trademark law should be for trademarks and not for functional features of products. The doctrine of functionality has long served the role of excluding from trademark protection the functional features of articles. The doctrine of functionality thus assists in preventing the extension of expired patents. It also prevents the use of the Trademarks Act to obtain patent-type monopolies over functional features of unpatented articles. At root, the doctrine of functionality serves as a means to distinguish between the trade-mark as signifier and the underlying product or packaging.”⁹⁶

QUALITEX CO v JACOBSON PRODUCTS CO

514 U.S. 159 (1995) [USA]

The functionality doctrine prevents trademark law, which seeks to promote competition by protecting a firm’s reputation, from instead

89 See also the absolute prohibition of the registrations of signs consisting exclusively of— (a) the shape which results from the nature of the goods themselves, (b) the shape of goods which is necessary to obtain a technical result, or (c) the shape which gives substantial value to the goods. (UK Act s 3(2)).

90 BGH Case I ZR 17/05 – Pralinenform II (22 April 2010 [Germany]).

91 *In re Pacer Technology* 338 F.3d 1348, 67 USPQ2d 1629 (Fed. Cir. 2003) referring to *Wal-Mart Stores Inc v Samara Bros Inc* 529 US 205, 210 (2000); *Two Pesos Inc v Taco Cabana Inc* 505 US 763, 768 (1992); *Tone Bros Inc v Sysco Corp* 28 F.3d 1192, 1206 (Fed Cir 1994); and *Seabrook Foods Inc . Bar-Well Foods Ltd* 568 F.2d 1342, 1344 (CCPA 1977).

92 The answer is in the negative: *Lego Juris A/S v OHIM – Mega Brands Inc (LEGO)* Case C48-09P [ECJ].

93 *Beecham Group Plc v Triomed (Pty) Ltd* [2002] ZASCA 109 [South Africa].

94 *Bergkelder Beperk v Vredendal Ko-op Wynmakery* (105/05) [2006] ZASCA 5 [South Africa].

95 *Lubbe NO v Millennium Style* [2007] ZASCA 10 [South Africa].

96 Teresa Scassa *The Doctrine of Functionality in Trade-mark Law Post Kirkbi* (2007) 21 *IPJ* 87.

inhibiting legitimate competition by allowing a producer to control a useful product feature. It is the province of patent law, not trademark law, to encourage invention by granting inventors a monopoly over new product designs or functions for a limited time after which competitors are free to use the innovation. If a product's functional features could be used as trademarks, however, a monopoly over such features could be obtained without regard to whether they qualify as patents and could be extended forever (because trademarks may be renewed in perpetuity).

Functionality doctrine therefore would require, to take an imaginary example, that even if customers have come to identify the special illumination enhancing shape of a new patented light bulb with a particular manufacturer, the manufacturer may not use that shape as a trademark, for doing so, after the patent had expired, would impede competition - not by protecting the reputation of the original bulb maker, but by frustrating competitors' legitimate efforts to produce an equivalent illumination enhancing bulb. This Court consequently has explained that, "[i]n general terms, a product feature is functional," and cannot serve as a trademark, "if it is essential to the use or purpose of the article or if it affects the cost or quality of the article," that is, if exclusive use of the feature would put competitors at a significant non reputation related disadvantage.

BOGRAIN SA's TRADEMARK APPLICATION

[2005] RPC 14 (CA) [UK]

As a matter of principle I do not accept that just because a shape is unusual for the kind of goods concerned, the public will *automatically* take it as denoting trade origin, as being the badge of the maker. At the heart of trademark law is the function of a trademark as an indication of origin. The perception of the public – of the average consumer – is what matters. [Counsel] helpfully pointed out that the kinds of sign which may be registered fall into a kind of spectrum as regards public perception. This starts with the most distinctive forms such as invented words and fancy devices. In the middle are things such as semi-descriptive words and devices. Towards the end are shapes of containers. The end would be the very shape of the goods. Signs at the beginning of the spectrum are of their very nature likely to be taken as put on the goods to tell you who made them. Even containers, such as the fancy Henkel container, may be perceived as chosen especially by the maker of the contents (e.g. shampoo) to say "look – here is

the product of me, the maker of the contents". But, at the very end of the spectrum, the shape of goods as such is unlikely to convey such a message. The public is not used to mere shapes conveying trademark significance. The same point was made about slogans in *Das Prinzip der Bequemlichkeit* [ECJ, 21 October 2004, *OHIM / Erpo Möbelwerk* C-64/02 P, ECR 2004 I-10031, par 35]:

"the [trademark registering] authorities may take account of the fact that average consumers are not in the habit of making assumptions about the origin of products on the basis of such slogans."⁹⁷

Bang & Olufsen v OHIM

General Court, 6 October 2011, T-508/08

Signs, which consist exclusively of the shape which gives substantial value to the goods, are not to be registered. The Court finds that in the present case the shape for which registration was sought has a very specific design. In the Court's view, that design is an essential element of Bang & Olufsen's branding and increases the value of the product concerned. Furthermore, it is apparent from extracts from distributors' websites and online auction or second-hand websites that the aesthetic characteristics of that shape are emphasised first and that the shape is perceived as a kind of pure, slender, timeless sculpture for music reproduction, which makes it an important selling point. Accordingly, the Court holds that OHIM did not make any error in finding that, independently of the other characteristics of the product at issue, the shape for which registration was sought gives substantial value to that product.

PHILIPS RAZOR

Bundesgerichtshof [Germany]

BGH, decision of November 17, 2005 – I ZB 12/04

The item forming the contested mark was an attachment for a razor, consisting of three razor heads arranged on a disk in the form of an equilateral triangle.

The real obstacle to the protection of the contested mark was that it consisted solely of a shape that the item had to take in any case to fulfill its technical function. According to ECJ case law, the shape of a product was not eligible for protection as a trademark if it was proved that the essentially functional characteristics of that shape

97 But the ECJ held that the Audi slogan *Vorsprung durch Technik* is a valid trademark: *Audi AG v OHIM* Case C-398/08P of 21 January 2010.

could be ascribed to its technical effect, regardless of whether alternative shapes with the same technical effect could be imagined.

33. Color marks: A distinctive color may have the necessary ability to distinguish in the trademark law sense but it is seldom that color *per se* can act as a source identifier.

WAL-MART STORES INC v SAMARA BROTHERS INC

529 US 205 (2000) [USA]

It seems to us that design, like color, is not inherently distinctive. The attribution of inherent distinctiveness to certain categories of word marks and product packaging derives from the fact that the very purpose of attaching a particular word to a product, or encasing it in a distinctive packaging, is most often to identify the source of the product. Consumers are therefore predisposed to regard those symbols as indication of the producer.

In the case of product design, as in the case of color, we think consumer predisposition to equate the feature with the source does not exist. Consumers are aware of the reality that, almost invariably, even the most unusual of product designs – such as a cocktail shaker shaped like a penguin – is intended not to identify the source, but to render the product itself more useful or more appealing.

The fact that product design almost invariably serves purposes other than source identification not only renders inherent distinctiveness problematic; it also renders application of an inherent-distinctiveness principle more harmful to other consumer interests. Consumers should not be deprived of the benefits of competition with regard to the utilitarian and esthetic purposes that product design ordinarily serves by a rule of law that facilitates plausible threats of suit against new entrants based upon alleged inherent distinctiveness.

KRAFT FOODS (MILKA MARK)

BGH, ruling of October 7, 2004 - I ZR 91/02 [Germany]

The right in an abstract color mark can be infringed only where the protected color is used as an indication of origin. This is because the main function of a mark is to guarantee the origin of the products or services identified by the mark to the consumer or end-user by enabling him/her to distinguish these products or services from products or services of other origins without risk of confusion.

The protections granted to the mark owner are there to ensure that the mark can fulfill this function, and are therefore limited to cases in which the use of the indication by a third party may interfere with the function of the mark – in particular, with its primary function of guaranteeing the origin of the goods to the consumer.

However, only in exceptional cases may color used on the packaging of a product be deemed an indication of origin. This is because consumers are not accustomed to drawing conclusions regarding the origin of products solely from their coloring or that of their packaging without also considering graphical or textual elements, as it is in principle not current practice to use colors *per se* as means of identification. For such an exception to apply, the color must itself stand out amid all the other elements in such a way that it is understood as a means of identification. This may, for instance, be the case when, on the one hand, the protected color has gained greater brand distinctiveness through use and the public has consequently become accustomed to inferring an identification of origin from products of the color protected in the manner in question. On the other hand, it may also occur when, in the contested use, too, the color is an essential medium of design that has retained its currency thanks to conventional indications of origin.⁹⁸

G. OWNERSHIP AND REGISTRATION

34. *Registration required:* In order to be able enforce statutory trademark rights, the trademark must be registered.

- The trademark owner must prove the registration.
- A certificate of registration or one authenticated by the registry is usually regarded as *prima facie* evidence of registration.

KIRKBI AG v RITVIK HOLDINGS INC

2005 SCC 65 [Canada]

Registration of a trademark gives the registrant the exclusive right to the use throughout Canada of the trademark and a right of action to remedy any infringement of that right. In addition, in order to exercise those rights, the existence of the mark itself does not have to be established. Registration is evidence enough. Nonetheless,

98 See also the BGH Decision of 19 February 2009 – Case I ZR 195/06 –UHU.

marks remain marks, whether registered or unregistered, because their legal characteristics are the same.

35. *The registered owner:* The right to enforce the statutory rights is usually reserved for the registered owner of the trademark.⁹⁹ This depends on the terms of the statute.

FUJIAN LIGHT INDUSTRIAL PRODUCTS v FUZHOU WAN DA PENCIL [ZHI ZHONG ZI NO.8 (1999)]

The Supreme People's Court of the People's Republic of China:

The trademark registrant enjoys the exclusive rights conferred by registered trademark protected by Trademark Law. The licensee of an exclusive trademark license agreement, with the authorization of trademark's owner, has the right to use exclusively the trademark and prevent others from using the trademark. Therefore, this kind of licensee has right to bring infringement suit alone or jointly with the trademark registrant. The licensee of non-exclusive agreement just has the right to use the trademark. His right has neither monopolistic character nor effect to prevent others from using the trademark. Hence, this kind of right cannot be the base for bringing trademark infringement action.

36. *Reputation or damages not required:* Trademark rights can be enforced even if the relevant mark has no reputation; and an injunction can be obtained without proof of loss or damages. In some jurisdictions compensation may also be recoverable without proof of actual loss.

37. *Use of a registered mark by the owner is not infringement:*¹⁰⁰ Use of a trademark in relation to goods or services for which it is registered cannot amount to infringement of another (even earlier) registered trademark. The owner of the senior mark, who is aggrieved by a later registration, must apply for its cancellation before being able to rely on infringement of the senior mark by the use of the junior mark.

38. *Common-law and other rights are not affected:* The existing common-law (in common-law jurisdictions) or other statutory rights relating to unregistered marks are not affected by the registration of a trademark.

99 In the UK s. 14: "(1) An infringement of a registered trademark is actionable by the proprietor of the trademark. (2) In an action for infringement all such relief by way of damages, injunctions, accounts or otherwise is available to him as is available in respect of the infringement of any other property right."

100 Cf. UK s 11(1): "A registered trademark is not infringed by the use of another registered trademark in relation to goods or services for which the latter is registered."

- A party with an unregistered mark may rely on unfair competition or passing off as a separate cause of action.
- A registered right cannot affect the use of an existing prior right, albeit unregistered, which was obtained through use.
- The Paris Convention contains special provisions regarding unfair competition that have been complemented by TRIPS.¹⁰¹

101 This is dealt with later.

TRADEMARKS: INFRINGEMENT

CHAPTER III

- A. INTRODUCTION (1-5)
- B. THE USE OF IDENTICAL MARKS (6-8)
- C. THE USE OF MARKS ON SIMILAR GOODS OR SERVICES (9-12)
- D. GOODS OR SERVICES IN RESPECT OF WHICH THE MARK IS REGISTERED (13-15)
- E. USE IN THE COURSE OF TRADE AND TRADEMARK USE (16-20)
- F. THE USE OF ADDITIONAL MATTER (21-22)
- G. NOTIONAL USE (23-24)

A. INTRODUCTION

1. *Scope of chapter:* This chapter deals with the different types of trademark infringement and some basic concepts. It must be read with the subsequent chapters that deal with specific aspects of infringement. In the discussion that follows the emphasis is on infringement where there is a probability or likelihood of confusion (or confusion or deception, as some laws will have it) between the registered mark and the allegedly infringing mark (in US parlance, the senior and junior mark respectively). Judgments dealing with the registration of marks will also be cited because the test for registering a later (junior) mark is that it may not be identical or confusingly similar to a registered (senior) mark.

2. *The subjective nature of determining infringement:* Infringement judgments have a subjective element because they depend to an extent on a value judgment of the relevant forum.

FUTURE ENTERPRISES PTE LTD v MCDONALD'S CORP

[2007] SGCA 18 [Singapore]

The smorgasbord of trademark cases which has reached the appellate courts demonstrates the innumerable (and subjectively perceived) similarities and differences that can be conjured up and persuasively articulated by an imaginative and inventive legal mind. Expert and experienced judges, such as Laddie J, have described trademark infringement as “more a matter of feel than science” (in *Wagamama Ltd v City Centre Restaurants plc* [1995] FSR 713 at 732), and Chao Hick Tin JA similarly alluded to it as a matter of “perception” (in *The Polo/Lauren Co, LP v Shop-In Department Store Pte Ltd* [2006] 2 SLR 690). In the light of the highly subjective nature of assessing similarity and the likelihood of confusion, we agree with the approach that an appellate court should not disturb the findings of fact of a trademark tribunal unless there is a material error of principle.

This case dealt with “MacCoffee” and “McCafé”, the latter a trademark of McDonald’s, and the Court found that the former was too close for comfort. The next case, heavily edited for present purposes, provides a feel of the problem. It also deals with registration matters but the underlying problems are the same.

MCDONALD'S CORP v FUTURE ENTERPRISES PTE LTD

[2005] 1 SLR 177 [Singapore]

This appeal related to McDonald's, opposition to the application for registration of three trademarks under class 30 by FE. McDonald's failed [below and we] heard the appeal and dismissed it.

McDonald's, has, *inter alia*, the following marks registered here: (a) BIG MAC – in class 29 and class 30; (b) MAC FRIES – in class 29; (c) SUPERMAC – in class 29; (d) EGG McMuffin – in classes 29 and 30; (e) McChicken – in class 30; (f) McNuggets – in classes 29 and 30; [and] the main mark 'McDonald's'.

FE applied to register the three application marks, "MacTea", "MacChocolate" and "MacNoodles" in class 30 and, in each case, with the eagle device.

The trial judge did not think that the subject marks were confusingly similar, either visually or orally, with McDonald's marks. Moreover, the goods covered by the application marks were different from those to which McDonald's family of marks applied.

The crux of McDonald's case was that, in all their marks, the common distinctive syllable was the prefix "Mc" which was the essential feature which links all their marks. Because of that, the adoption by FE of the prefix "Mac" in the application marks could give the impression that FE's products came from the same source as that of McDonald's.

It is quite apparent that over the years, McDonald's has taken proceedings in various jurisdictions to oppose third parties' applications to register marks involving the prefix "Mc" or "Mac". In some it succeeded and in others it failed. Invariably, in each case the trademark officer or the court would go into a careful examination of the facts and circumstances surrounding the proposed use of the applicant's mark and how the various McDonald's marks were being used and the likelihood of the new proposed mark being mistaken as that of McDonald's.

For example in those cases involving the marks "McBagel", "McPretzel" and "McSalad", McDonald's succeeded in [the USA and in respect of] the mark "McIndians" in respect of "restaurant, cafe and cafeteria services; preparing food and drink for consumption" in [the UK]. [McIndians not only sold Indian food, but also Southern fried chicken, cheeseburgers, French fries and shakes.]

In the meantime, in two 1997 Australian Trademark Office cases [relating to] *McMint* and *McVeg*, McDonald's opposition failed [but in] the later Australian case of *McDonald's Corporation v Macri Fruit Distributors Pty Ltd* [2000] [concerning] "McSalad" and "McFresh" [McDonald's succeeded].

Finally, we will refer to *Yuen* (2001) where the court disregarded the objection of McDonald's and allowed the registration of the mark "McChina" in the [UK], [and] the judge [said] that McDonald's, was "virtually seeking to monopolize all names and words with prefix Mc or Mac, at least in relation to food or restaurant services".

Here we would refer to two Canadian cases. First is *McDonald's Corp v Silcorp Ltd* (1989) 24 CPR (3d) 207 where Strayer J ruled that McDonald's could not claim a monopoly over the use of "Mc" or "Mac" syllables either alone or in combination with other words. Second is *McDonald's Corp v Coffee Hut Stores Ltd* (1994) 55 CPR (3d) 463 where the Federal Court of Canada, in an application to register the mark "McBeans" in respect of gourmet coffee, while noting that McDonald's had established a reputation in the business of fast-food restaurants, said that there was nothing inherently distinctive about the McDonald's marks once one looked outside that area of business.

3. Trademark infringement involving confusion: Trademark infringement may be one of three types. Where the likelihood of confusion is of the essence, it may either be primary or secondary. Article 16(1) of the TRIPS Agreement deals with these two instances:

The owner of a registered trademark shall have the exclusive right to prevent all third parties not having the owner's consent from using in the course of trade identical or similar signs for goods or services which are identical or similar to those in respect of which the trademark is registered where such use would result in a likelihood of confusion.¹⁰²

Primary infringement consists of the use of any sign, which is identical with the registered trademark, in relation to goods or services which are identical with those for which the trademark is registered, in the course of trade, without the consent of the trademark proprietor.

102 Inapplicable part of the text omitted.

Secondary infringement consists of the use of any sign where, because of its identity with, or similarity to, the registered trademark and the identity or similarity of the goods or services covered by that trademark and the sign, there exists a likelihood of confusion on the part of the public, which includes the likelihood of association between the sign and the trademark in the course of trade, without the consent of the trademark proprietor.

4. *Trademark infringement where confusion is not required:* There is a further type of infringement where confusion is not required - it applies to well-known trademarks only. The TRIPS Agreement deals with the matter in Art. 16(3) and this is reflected in the EU Directive No. 2008/95 (Art. 5.2) in these terms:

Any Member State may also provide that the proprietor shall be entitled to prevent all third parties not having his consent from using in the course of trade any sign which is identical with, or similar to, the trademark in relation to goods or services which are not similar to those for which the trademark is registered, where the latter has a reputation in the Member State and where use of that sign without due cause takes unfair advantage of, or is detrimental to, the distinctive character or the repute of the trademark.

5. *The UK Trademarks Act:* This Act (s 10) is typical of a statute which provides for the three types of protection envisaged by TRIPS and the Directive.

Section 10(1) deals with primary infringement:

A person infringes a registered trademark if he uses in the course of trade a sign which is identical with the trademark in relation to goods or services which are identical with those for which it is registered.

Section 10(2) is concerned with secondary infringement:

A person infringes a registered trademark if he uses in the course of trade a sign where because:

- the sign is identical with the trademark and is used in relation to goods or services similar to those for which the trademark is registered,
- the sign is similar to the trademark and is used in relation to goods or services identical with or similar to those for which the trademark is registered,

there exists a likelihood of confusion on the part of the public, which includes the likelihood of association with the trademark.

Section 10(3) deals with trademarks with a reputation:

A person infringes a registered trademark if he uses in the course of trade a sign which:

- is identical with or similar to the trademark, and
- is used in relation to goods or services which are not similar to those for which the trademark is registered,

where the trademark has a reputation in the United Kingdom and the use of the sign, being without due cause, takes unfair advantage of, or is detrimental to, the distinctive character or the repute of the trademark.

The differences between the subsections were dealt with in the two judgments next quoted.

JOHNSTONE v R
[2003] UKHL 28 [UK]

Section 10 deals with several different situations. Section 10(1) concerns the case where a person in the course of trade uses a sign identical with a registered trademark in relation to goods identical with those for which it is registered. Such use constitutes infringement.

Section 10(2) addresses cases where either (a) a sign identical with a registered trademark is used in relation to goods similar to those for which the trademark is registered or (b) a sign similar to a registered trademark is used in relation to goods identical with or similar to those for which the trademark is registered. In such cases user constitutes infringement if there exists a likelihood of confusion on the part of the public.

Section 10(3) concerns cases where a sign identical with or similar to a registered trademark is used in relation to goods not similar to those for which the trademark is registered. Then, in short, user constitutes infringement where the trademark has a reputation within the United Kingdom and the sign takes unfair advantage of, or is detrimental to, the distinctive character or the repute of the trademark.

ARSENAL FOOTBALL CLUB v REED

[2003] EWCA Civ 696 [UK]

It is important to note the difference between subsections (1) and (2) of s 10. This case is [under s 10(1) and] concerned with identity of registered trademark and sign and identity of goods. Thus infringement will occur if the alleged infringer “uses in the course of trade” the sign.

Subsection (2) deals with use when the goods and/or the signs are not identical. In those circumstances a likelihood of confusion must be shown. That requires the proprietor to establish that there is a risk that the public might believe that the goods in question came from the same undertaking or an economically linked undertaking.

B. THE USE OF IDENTICAL MARKS

6. *Presumption of confusion:* The use of an identical trademark mark on identical goods or services necessarily gives rise to confusion. Consequently, the TRIPS Agreement (Art. 16.1) provides that in a case of the use of an identical sign for identical goods or services, a likelihood of confusion is to be presumed. Since confusion is assumed, it is not mentioned as a separate requirement and need not be established by means of evidence. In such a case the protection is absolute.

7. *Identical marks:* The definition of identity implies that the two elements compared should be the same in all material respects. But in deciding whether a mark and a sign are identical, the decision must be based on the overall impression created by them, including their visual, aural and conceptual similarities. The effect of this is that insignificant differences must be ignored in making the comparison.¹⁰³

INTERNATIONAL BUSINESS MACHINES CORP v WEB-SPHERE LTD

[2004] EWHC 529 [UK]

Thus [s 10(1)] gives absolute protection, but it depends on identity between the mark and the sign and identity of goods and services. [Section 10(2)] only requires similarity, rather than identity, but it also requires a likelihood of confusion.

103 See also *Bayer Cropscience SA v Agropharm* [2004] EWHC 1661 [UK].

LTJ DIFFUSION v SADAS VERTBAUDET

ECJ, 20 March 2003, C-291/00, ECR 2003, I-2799

The criterion of identity of the [junior] sign [“Arthur et Felice”] and the [registered] trademark [“Arthur”] must be interpreted strictly. The very definition of identity implies that the two elements compared should be the same in all respects. Indeed, the absolute protection in the case of a sign which is identical with the trademark in relation to goods or services which are identical with those for which the trademark is registered, which is guaranteed by Art. 5(1)(a) of the directive, cannot be extended beyond the situations for which it was envisaged, in particular to those situations which are more specifically protected by Art. 5(1)(b) of the directive.

There is therefore identity between the sign and the trademark where the former reproduces, without any modification or addition, all the elements constituting the latter.

However, the perception of identity between the sign and the trademark must be assessed globally with respect to an average consumer who is deemed to be reasonably well informed, reasonably observant and circumspect. The sign produces an overall impression on such a consumer. That consumer only rarely has the chance to make a direct comparison between signs and trademarks and must place his trust in the imperfect picture of them that he has kept in his mind.

Since the perception of identity between the sign and the trademark is not the result of a direct comparison of all the characteristics of the elements compared, insignificant differences between the sign and the trademark may go unnoticed by an average consumer.¹⁰⁴

- 8.** *Identical marks on different goods:* The use of an identical mark is not, as such, an infringement of a trademark. For primary infringement, the marks must be used on identical goods or services.

CÉLINE SARL v CÉLINE SA

ECJ, 11 September 2007, C-17/06, ECR 2007, I-7041

As is clear from the Court’s case-law, the proprietor of a registered mark may prevent the use of a sign by a third party which is identical

¹⁰⁴ For a critical analysis of the ECJ judgment see *Reed Executive plc v. Reed Business Information Ltd* [2004] EWCA (Civ) 159 [UK]. This judgment held that “Reed Business Information” was not identical to the trademark “Reed”. The same applies to “Compass” and “Compass Logistics”: *Compass Publishing v Compass Logistics* 2004 EWHC 520[UK].

to his mark under Article 5(1)(a) of the directive only if the following four conditions are satisfied:

- that use must be in the course of trade;
- it must be without the consent of the proprietor of the mark;
- it must be in respect of goods or services which are identical to those for which the mark is registered, and
- it must affect or be liable to affect the functions of the trademark, in particular its essential function of guaranteeing to consumers the origin of the goods or services.

C. THE USE OF MARKS ON SIMILAR GOODS OR SERVICES

9. *Similarity of goods or services*: The use of an identical mark could amount to a secondary (section 10(2)) infringement if the goods or services in respect of which they are used are similar. There are two possibilities depending on whether an identical or a confusingly similar mark is used. In this paragraph the focus is on the similarity of goods or services: when are goods or services similar?

ASSEMBLED INVESTMENTS (PTY) LTD v OHIM & WATERFORD WEDGWOOD plc

CFI, 12 June 2007, T-105/05, ECR 2007, II-60

The applicant sought to register the trademark “Waterford” in respect of wines from a certain area in South Africa. The owner of the trademark “Waterford” in relation to glassware opposed the registration. Since the marks are identical the question that remained was whether the goods (wine and glassware) are similar. The court found that they were not and dismissed the opposition.¹⁰⁵

It should also be borne in mind that, in order to assess the similarity of the goods in question, account must be taken of all the relevant factors which characterize the relationship between those goods, those factors including, in particular, their nature, their intended purpose and their method of use and whether they are in competition with each other or are complementary. Next, the assessment of the similarity of the goods should be restricted, as regards the earlier mark, to “articles of glassware”, since the other goods covered by the earlier mark have no connection with wine. As is apparent from the contested decision, that category includes carafes, decanters and stemware or wine glasses, articles which are specifically intended to be used for the consumption of wine.

105 The subsequent appeal was dismissed: ECJ, 7 May 2009, *Waterford Wedgwood / Assembled Investments (Proprietary) and OHIM*, C-398/07 P, ECR 2009. I-75.

The parties do not dispute that the goods at issue, namely the articles of glassware, on the one hand, and, on the other hand, the wine, are distinct by nature and by their use, that they are neither in competition with one another nor substitutable and that they are not produced in the same areas.

As regards distribution channels, it is true that wine and certain articles of glassware are sometimes sold in the same places, such as specialist wine retailers. However, in the absence of information proving the contrary, it appears that such sales represent no more than a negligible proportion of the overall sales of the articles of glassware concerned.

Likewise, wine glasses and wine, although normally marketed separately, are occasionally distributed together for promotional purposes. However, it has not been shown that that practice by wine producers is of any significant commercial importance. In addition, the distribution of wine glasses with wine is normally perceived by the consumers concerned as a promotional attempt to increase sales of the wine rather than as an indication that the producer concerned devotes part of his activity to the distribution of articles of glassware.

The use of keywords, which are trademarks, by an online service provider to promote its own service does not amount to use of those trademarks in relation to the goods.

L'ORÉAL SA v eBAY INTERNATIONAL AG

ECJ, 12 July 2011, C-324/09

In that regard, the first point to make is that, in so far as eBay used keywords corresponding to L'Oréal trade marks to promote its own service of making an online marketplace available to sellers and buyers of products, that use was not made in relation to either (i) goods or services "identical with those for which the trade mark is registered" or (ii) goods or services similar to those for which the trade mark is registered.

In view of the foregoing, the answer to the eighth question is that the operator of an online marketplace does not "use" – for the purposes of Article 5 of Directive 89/104 or Article 9 of Regulation No 40/94 – signs identical with or similar to trade marks which appear in offers for sale displayed on its site.

10. *The factors to consider in determining similarity between goods or services:*

BRITISH SUGAR PLC v JAMES ROBERTSON & SONS LTD

[1996] RPC 281 [UK]

Thus I think the following factors must be relevant in considering whether there is or is not similarity:

- the respective uses of the respective goods or services;
- the respective users of the respective goods or services;
- the physical nature of the goods or acts of service;
- the respective trade channels through which the goods or services reach the market;
- in the case of self-serve consumer items, where in practice they are respectively found or likely to be found in supermarkets and in particular whether they are, or are likely to be, found on the same or different shelves;
- the extent to which the respective goods or services are competitive.

This inquiry may take into account how those in trade classify goods, for instance whether market research companies, who of course act for industry, put the goods or services in the same or different sectors.

11. *The similarity of goods or services is a question different from the likelihood of confusion:* The law is not clear on this aspect. The judgment next cited appears in this respect to be in conflict with a statement in the quoted ECJ Judgment in *Assembled Investments (Pty) Ltd v OHIM and Waterford Wedgwood Plc*.

BRITISH SUGAR PLC v JAMES ROBERTSON & SONS LTD

[1996] RPC 281

[The plaintiff seeks] to elide the questions of confusion and similarity [of goods]. [It] contends that there is “use in relation to a product so similar to a dessert sauce that there exists a likelihood of confusion because the product may or will be used for identical purposes.” I do not think it is legitimate to elide the question in this way. The subsection does not merely ask “will there be confusion?”: it asks “is there similarity of goods?”, if so, “is there a likelihood of confusion?” The point is important. For if one elides the two questions then a “strong” mark would get protection for a greater range of goods than a “weak” mark. For instance KODAK for socks or bicycles might well cause confusion, yet these goods are plainly dissimilar from films or cameras.

I think the question of similarity of goods is wholly independent of the particular mark the subject of registration or the defendant's sign. How then is the court to approach the question of similarity? I think I must consider the matter as a matter of principle. First it should be noted that the wider the scope of the concept, the wider the absolute scope of protection of a mark may be. In effect a registration covers the goods of the specification plus similar goods. No one may use the registered mark or a similar mark for any of those goods unless he has some other defence. This suggests caution. Otherwise, however narrow a specification, the actual protection will be wide. In particular this would be so in the important sort of case where a mark owner only got registration on the basis of actual distinctiveness for a narrow class of goods. It would surely be wrong that he should then in practice get protection for a wide range of goods. If a man wants wide protection he can always ask for it and will get it only if his claim is justified.

12. *"Same class" and "same description":*

KENNY FOOD MANUFACTURING v LEE TAK FUK TRADING

HCA3352/2000 [Hong Kong]

The fact that certain goods may fall within the same class is not evidence that they are "of the same description". Further, it has been held that the use of a mark registered for flour on a loaf of bread is not use of the mark in relation to flour (since flour, as such, is no longer present in the loaf of bread).

D. GOODS OR SERVICES IN RESPECT OF WHICH THE MARK IS REGISTERED

13. *Classes:* Goods and services are registered in classes in terms of the Nice Classification.¹⁰⁶ *The Nice Agreement Concerning the International Classification of Goods and Services for the Purposes of the Registration of Marks (1957)* established a classification of goods and services for the purposes of registering trademarks. The classification consists of a list of classes—there are thirty-four classes for goods and eleven for services—and an alphabetical list of goods and services. The latter comprises some 11 000 items. Both lists are, from time to time, amended and supplemented by a committee of experts.

106 The current version of the classification is available at www.wipo.int.

A typical class for goods looks like this:

Class 3: Bleaching preparations and other substances for laundry use; cleaning, polishing, scouring and abrasive preparations; soaps; perfumery, essential oils, cosmetics, hair lotions; dentifrices.

And one for services:

Class 36: Insurance; financial affairs, monetary affairs; real estate affairs.

BRITISH SUGAR PLC v JAMES ROBERTSON & SONS LTD

[1996] RPC 281[UK]

Under the Trademarks Acts goods and services are divided into a series of classes. The main purpose of the classes is to enable trademark searching to be carried out. For instance if you have a new mark for a medicine then you search the relevant class, class 5. The schedule itemizes a variety of goods in various classes and classes of services. The classification forms part of an internationally agreed system and is known as the Nice Classification, following the 1934 international conference which took place there. It is widely (indeed I believe universally) used by trademark registries throughout the world and by the so-called “international” system [regulated by] the Madrid Agreement [and the Madrid] Protocol. The classification could not and does not explicitly mention all types of goods and services in detail. But there is a very large and comprehensive list of goods and services by which the Registrar goes. His judgment on where goods go is, for administrative reasons, made final. This list is used internationally and is amended from time to time, normally to deal with new kinds of goods or services. Occasionally a particular kind of article or service is moved from one class to another.

Generally there is no difficulty in identifying which class is relevant for a particular article. But borderline cases are not infrequent. For these the Registrar often uses the practice of describing the goods or services and adding the words included in this Class or included in Class X. The effect of this is to confine the specification to goods which fall within the description and which also were, at the time of registration, put in that class by the Registrar.

[Earlier in the judgment he said]: When it comes to construing a word used in a trademark specification, one is concerned with how the product is, as a practical matter, regarded for the purposes of trade. After all a trademark specification is concerned with use in trade.

14. Service marks: Trademarks for services are of a relatively recent origin and an obligation to provide for them arises not only from TRIPS but also from the Trademark Law Treaty (1994) and the Singapore Treaty on the Law of Trademarks. Initially, trademarks could only be registered for goods. There are, accordingly, very few judgments dealing with service marks but since the principles are the same it does not really matter.

The Indian Trademarks Act defines a service as one of any description which is made available to potential users and includes the provision of services in connection with business of any industrial or commercial matters such as banking, communication, education, financing, insurance, chit funds, real estate, transport, storage, material treatment, processing, supply of electrical or other energy, boarding, lodging, entertainment, amusement, construction, repair, conveying of news or information and advertising.

15. Choice of class: A trademark such as CHANEL NO 5 (one may presume) will be registered in class 3 because it is a perfume. It may be registered for all the goods in the class or it may be limited to perfumes because the owner may consider that perfumes and dentifrices are not related or it may not have any interest in dentifrices. The unauthorized use of CHANEL NO 5 on perfumes will be a section 10(1) infringement. The unauthorized use of the trademark on dentifrices may amount to a section 10(2) infringement and, since it is a mark with a reputation, it may also amount to a section 10(3) infringement. What this means is that the choice of a narrow specification of goods or services does not exclude the possibility of wider protection.

ASSOCIATED NEWSPAPERS LTD v EXPRESS NEWSPAPERS

[2003] EWHC 1322 [UK]

In approaching this subject I think it is necessary to bear in mind that it is for the proprietor to decide the width or narrowness of the specification of goods he wishes to have covered by a registered trademark. Furthermore, because of the provisions of s 10(2), a narrow classification does not mean that the proprietor is prevented from suing in respect of goods outside the specification.

E. USE IN THE COURSE OF TRADE AND TRADEMARK USE

16. Meaning of trademark use: In order to infringe, the defendant must have used its mark in the course of trade and the use must have been trademark use, i.e., to indicate origin. The case law on these issues is not

harmonious¹⁰⁷ because the requirement is not necessarily expressly required by TRIPS or statutes, although it is implicit in the whole concept of trademark law that use in the course of trade must be “trademark use”.¹⁰⁸

L'ORÉAL SA v eBAY INTERNATIONAL AG

ECJ, 12 July 2011, C-324/09

It is important to recall that the exclusive rights conferred by trademarks may, as a rule, be relied on only as against economic operators. Indeed, for the proprietor of a trade mark to be entitled to prevent a third party from using a sign identical with or similar to his trade mark, the use must take place in the course of trade.

Accordingly, when an individual sells a product bearing a trade mark through an online marketplace and the transaction does not take place in the context of a commercial activity, the proprietor of the trade mark cannot rely on his exclusive right. If, however, owing to their volume, their frequency or other characteristics, the sales made on such a marketplace go beyond the realms of a private activity, the seller will be acting “in the course of trade”.

With regard to internet advertising on the basis of keywords corresponding to trade marks, the Court has already held that a keyword is the means used by an advertiser to trigger the display of his advertisement and is therefore use “in the course of trade”.

JOHNSTONE v R

[2003] UKHL 28 [UK]

The message conveyed by a trademark has developed over the years, with changing patterns in the conduct of business. But the essence of a trademark has always been that it is a badge of origin. It indicates trade source: a connection in the course of trade between the goods and the proprietor of the mark. That is its function. Hence the exclusive rights granted to the proprietor of a registered trademark are limited to use of a mark likely to be taken as an indication of trade origin. Use of this character is an essential prerequisite to infringement. Use of a mark in a manner not indicative of trade origin of goods or services does not encroach upon the proprietor's monopoly rights. Dillon LJ observed trenchantly in *Mothercare UK Ltd v Penguin Books* [1988] RPC 113:

107 *Cf Anheuser Busch Inc v Budweiser Budvar National Corp* [2002] NZCA 264 (CA) [New Zealand].

108 The Nigerian Trademarks Act is explicit because there a trademark is deemed to be infringed by any person who uses a mark identical with it or so nearly resembling it as to be likely to deceive or cause confusion, in the course of trade, in such manner as to render the use of the mark likely to be taken as being use as a trademark.

“it stands to reason that a Trademarks Act would only be concerned to restrict the use of a mark as a trademark or in a trademark sense, and should be construed accordingly. If descriptive words are legitimately registered [as a trademark], there is still no reason why other people should not be free to use the words in a descriptive sense, and not in any trademark sense.”

In this regard I cannot forbear adding the extreme hypothetical example beloved of trademark lawyers. If a magazine publisher were to register an ordinary question mark, “?”, as a trademark for magazines this would not prevent the grammatical use of question marks on the covers of other magazines.

Trademark use is a convenient shorthand expression for use of a registered trademark for its proper purpose (that is, identifying and guaranteeing the trade origin of the goods to which it is applied) rather than for some other purpose. It is easy to recognize those cases which fall squarely on one side or other of the line. If a counterfeiter sells a cheap imitation watch under the trademark OMEGA, he is fraudulently engaging in trademark use (as he is, as [counsel] suggested, if he uses the mark HOMEGAS but prints the first and last letters very faintly). But if a publisher publishes a book named MOTHER CARE/OTHER CARE (a serious study of the upbringing of young children of working mothers) there is no infringement of the registered trademark of Mothercare UK Limited, despite the fact that the trademark is registered for many classes of goods, including books.

NATIONAL FITTINGS (M) Sdn Bhd v OYSTERTEC Plc

[2005] SGHC 225 [Singapore]

I am of the view that there ought to be the requirement that there be use as a trademark in the context of alleged trademark infringement. I draw support not only from [authority] but also from the fact that such a requirement will also ensure that the legal protection of the rights of registered trademark holders is so well-justified that it cannot be said that such holders are exploiting what might otherwise be labelled, in effect, as unnecessary or excessive monopoly rights. After all, trademarks have, in the final analysis, to do with the *origin* of the goods concerned.

17. *Descriptive use is not trademark use:*

THE GILLETTE CO v LA-LABORATORIES LTD OY

ECJ, 17 March 2005, C-228/03, ECR 2005, I-2337

The defendants sold razors in Finland consisting of a handle and a replaceable blade and blades on their own. These blades were sold under the Parason Flexor trademark and the following reference to Gillette's trademarks was made on the packaging: "All Parason Flexor and Gillette Sensor handles are compatible with this blade".

Applying the principles laid down by the ECJ in the following quotation, the Finnish Supreme Court found that the defendant did not infringe Gillette's trademark. The court held that the inclusion of such a reference in the packaging was necessary to indicate the intended purpose of the product and the reference was made in accordance with honest practices.¹⁰⁹

The ECJ held:¹¹⁰

The lawfulness or otherwise of the use of the trademark depends on whether that use is necessary to indicate the intended purpose of a product. Use of the trademark by a third party who is not its owner is necessary in order to indicate the intended purpose of a product marketed by that third party where such use in practice constitutes the only means of providing the public with comprehensible and complete information on that intended purpose in order to preserve the undistorted system of competition in the market for that product. [The court must determine] whether such use is necessary, taking account of the nature of the public for which the product marketed by the third party in question is intended.

The condition of "honest use" constitutes in substance the expression of a duty to act fairly in relation to the legitimate interests of the trademark owner. The use of the trademark will not be in accordance with honest practices in industrial and commercial matters if, for example: it is done in such a manner as to give the impression that there is a commercial connection between the third party and the trademark owner; it affects the value of the trademark

109 Finnish Supreme Court Judgment, 22.2.2006. KKO:2006:17.

110 The relevant provision of the EU Directive is reflected in these terms in the UK Act (Art. 6): "The trademark shall not entitle the proprietor to prohibit a third party from using, in the course of trade, (a) his own name and address; (b) indications concerning the kind, quality, quantity, intended purpose, value, geographical origin, the time of production of goods or of rendering of the service, or other characteristics of goods or services; (c) the trademark where it is necessary to indicate the intended purpose of a product or service, in particular as accessories or spare parts; provided he uses them in accordance with honest practices in industrial or commercial matters."

by taking unfair advantage of its distinctive character or repute; it entails the discrediting or denigration of that mark; or where the third party presents its product as an imitation or replica of the product bearing the trademark of which it is not the owner.

The fact that a third party uses a trademark of which it is not the owner in order to indicate the intended purpose of the product which it markets does not necessarily mean that it is presenting it as being of the same quality as, or having equivalent properties to, those of the product bearing the trademark. Whether there has been such presentation, depends on the facts of the case.

Whether the product marketed by the third party has been presented as being of the same quality as, or having equivalent properties to, the product whose trademark is being used is a factor which the referring court must take into consideration when it verifies that that use is made in accordance with honest practices in industrial or commercial matters.

WCVB-TV v BOSTON ATHLETIC ASSOCIATION

926 F2d 42 (1991) [USA]

The case concerned the use of the registered trademark BOSTON MARATHON by a television station in connection with its coverage of the event. The Court found that the US statutory fair use defense was properly asserted, reasoning that the trademark was used primarily in a descriptive manner. Because of the “timing, meaning, context, intent, and surrounding circumstances”, the court found that there was not a likelihood of confusion.

[T]he words BOSTON MARATHON do more than call attention to Channel 5’s program; they also *describe* the event that Channel 5 will broadcast. Common sense suggests that a viewer who sees those words flash upon the screen will believe simply that Channel 5 will show, or is showing, or has shown, the marathon, not that Channel 5 has some special approval from the [trademark holder] to do so. In technical trademark jargon, the use of words for descriptive purposes is called a “fair use”, and the law usually permits it even if the words themselves also constitute a trademark.

HÖLTERSHOFF v FREIESLEBEN

ECJ, 14 May 2002, C-2/00, ECR 2002, I-4187

The question was raised in proceedings between the owner of two registered trademarks, SPIRIT SUN and CONTEXT CUT covering diamonds for further processing as jewelry and precious stones for further processing as

jewelry respectively, and the defendant, concerning the latter's use of those trademarks for descriptive purposes in the course of trade.

In that regard, it is sufficient to state that, in a situation such as that described by the national court, the use of the trademark does not infringe any of the interests which Art. 5(1) is intended to protect. Those interests are not affected by a situation in which: the third party refers to the trademark in the course of commercial negotiations with a potential customer, who is a professional jeweller, the reference is made for purely descriptive purposes, namely in order to reveal the characteristics of the product offered for sale to the potential customer, who is familiar with the characteristics of the products covered by the trademark concerned, the reference to the trademark cannot be interpreted by the potential customer as indicating the origin of the product.

18. *Difference between descriptive use and trademark use:*

MIELE ET CIE GmbH & CO v EURO ELECTRICAL (PTY) LTD

1988 (2) SA 583 (A) [South Africa]

Miele registered the name MIELE as a trademark in classes covering a wide range of domestic and other electrical appliances. Some registrations consist of the word MIELE written in a special script and in accordance with certain precise dimensions (known as Miele's international script form). In terms of an agreement, the respondent was authorized to import, sell, service and repair Miele products and to use the word MIELE, in its international script form, in the name of its business and repair service. After cancellation of the agreement, the respondent continued to carry on trading as before and in consequence Miele applied for an order interdicting the respondent from infringing the trademarks by using the trade name "Miele Appliances" as the trade name of its shop.

[Counsel] submitted that it had not been established that Euro Electrical's use of the name MIELE on its shop front amounted to anything more than an advertisement of the fact that the business dealt in goods produced by Miele. And it was conceded by [Miele] that Euro Electrical was fully entitled to advertise the fact that it sold goods, which constituted genuine Miele appliances.

[The] submission is, in my view, unsound. The test, it seems to me, is how the ordinary, reasonable member of the purchasing public would regard and interpret Euro Electrical's use of the name MIELE on its shop front: whether as the trading style or name of the business or whether

as an advertisement that Miele goods were on sale in the shop. Having regard to the size, permanence, position and number of the neon signs and the general impression conveyed by them, I am of the opinion that the ordinary, reasonable member of the purchasing public would regard them as conveying the name of the shop or the business conducted in the shop; and not merely as advertisements. The placards, on the other hand, would be regarded as advertising material.

COMPAGNIE GENERALE MICHELIN v NATIONAL AUTOMOBILE, etc WORKERS UNION
[1997] 2 FC 306 [Canada]

The plaintiff, Michelin, is a French corporation with worldwide interests in the manufacture, distribution and sale of tires and automotive accessories. Michelin also provides tourism services, including the production of tourist guides and maps. Michelin held trademarks in MICHELIN and the Bibendum design (a drawing of a beaming marshmallow-like rotund figure composed of tires). The defendant (CAW), a trade union, attempted to unionize the employees of Michelin Canada's three tire plants. During the campaign, CAW distributed leaflets, displayed posters and issued information sheets that reproduced the name MICHELIN and the Bibendum design without the permission of Michelin. Michelin sought a permanent injunction and damages on the grounds that CAW violated its trademark rights. CAW denied that it infringed the trademarks on the ground that there was no trademark use. The court found that CAW had not used the trademarks in relation to goods or services and proceeded to hold that the plaintiff failed to prove "use" under s 20 of the Canadian Act, which also requires proof of use of the mark as trademark.

I accept the defendants' submission that they were not using the "Bibendum" design as a trademark to indicate that Michelin was the source of the pamphlets and leaflets. The defendants did not use the "Bibendum" design as a trademark but as a campaign tool to attract the attention of Michelin employees as they entered the factory gates. There could be no mistake that the CAW was the originator of the pamphlets and leaflets. CAW was not using the "Bibendum" to identify with Michelin's wares and services. Rather, the "Bibendum" was depicted to draw the eyes of the Michelin employees and stand in contrast to the usual corporate image.

In discussing the grounds for infringement under the Trademarks Act, it is relevant and crucial to pinpoint the purpose of the defendant CAW's depiction of "Bibendum". Since "Bibendum" was not used as a trademark, there is in effect no use at all of the "Bibendum".

The term “Michelin” on the defendant CAW’s information brochures also does not qualify as use of the trademark “as a trademark”. I do not accept the plaintiff’s submissions that the defendant CAW’s purpose in deploying “Michelin” on information sheets was to draw an inference that Michelin was the originator of the information sheet.

19. *Ornamental use is not necessarily trademark use:* A textbook example relates to the well-known Adidas trademark which (in general terms) consists of three parallel stripes. The use of two or four stripes on a garment may arguably be ornamental but, on the other hand, it may be trademark use. Whether a particular use is ornamental or not does not depend on the defendant’s intention, but rather on the public’s perception of the nature of the use.

ADIDAS-SALOMON AG v FITNESSWORLD TRADING LTD

ECJ, 23 October 2003, C-408/01, ECR 2003, I-12537

The fact that a sign is viewed as an embellishment by the relevant section of the public is not, in itself, an obstacle to the protection conferred where the degree of similarity is none the less such that the relevant section of the public establishes a link between the sign and the mark.

By contrast, where the relevant section of the public views the sign purely as an embellishment, it necessarily does not establish any link with a registered mark. That therefore means that the degree of similarity between the sign and the mark is not sufficient for such a link to be established.

The answer must therefore be that the fact that a sign is viewed as an embellishment by the relevant section of the public is not, in itself, an obstacle to the protection conferred where the degree of similarity is none the less such that the relevant section of the public establishes a link between the sign and the mark. By contrast, where the relevant section of the public views the sign purely as an embellishment, it necessarily does not establish any link with a registered mark, with the result that one of the conditions of the protection conferred is then not satisfied.

TOMMY HILFIGER LICENSING INC v INTERNATIONAL CLOTHIERS INC

2004 FCA 252 (CanLII)

The Trial Judge [concluded] that the [registered trademark] crests featured on the shirts and boys’ shorts sets were not included on the

garments and were not used for sale “for the purpose of distinguishing” them from the wares of others. As a result, he concluded that the respondent’s crest design had not been used as a trade-mark.

The only issue before us in this appeal is whether the respondent used its crest design “the purpose of distinguishing” its shirts and boys’ shorts sets “or so as to distinguish” them from those of others. In my view, the answer to that question must be an affirmative one.

In *Meubles Domani’s v. Guccio Gucci SpA* (1992) 43 CPR (3d) 372 (FCA) 379 this Court endorsed the point of view found in *Fox*,¹¹¹ that in determining whether a mark has been used as a trademark, the user’s intention and public recognition are relevant considerations, and that one or the other may be sufficient to demonstrate that the mark has been used as a trademark.

In my opinion, the Trial Judge erred in adopting an interpretation of the statute which required proof that the user had intended to use his mark for the purpose of distinguishing his wares from those of others. With the greatest of respect, it appears to me that the Trial Judge clearly failed to address what, in my view, was the crucial question, i.e. whether, irrespective of its intentions, the respondent had used its crest so as to denote the origin of the shirts and boys’ shorts sets, or used the crest in such a way as to have served the purpose of indicating origin.

20. *The exclusive right is conferred in order to ensure that the trademark can fulfill its function as a badge or origin:*

ARSENAL FOOTBALL CLUB plc v MATTHEW REED

ECJ, 12 November 2002, C-206/01, ECR 2002, I-10273

Arsenal is the internationally known football club known as Arsenal or the Gunners. Part of its business involves the sale of products bearing the words Arsenal, Arsenal Gunners and device marks for which it holds trademark registrations. Reed is a football merchandise business selling also souvenirs and memorabilia bearing the mentioned trademarks. The case against him was based on primary infringement. His defense was that that he used the word Arsenal and other trademarks as badges of allegiance and not as a badge of origin.

The registered trademark confers exclusive rights on its proprietor that exclusive right entitles the proprietor to prevent all third parties,

¹¹¹ Fox *The Canadian Law of Trademarks and Unfair Competition* (3 ed. Toronto: Carswell, 1972). Fox, in turn, relied heavily on *Nicholson & Sons, Ltd* (1931) 48 RPC 227 (Ch) 260.

acting without his consent, from using in the course of trade any sign which is identical to the trademark in relation to goods or services which are identical to those for which the trademark is registered.

For the trademark to be able to fulfill its essential role in the system of undistorted competition it must offer a guarantee that all the goods or services bearing it have been manufactured or supplied under the control of a single undertaking which is responsible for their quality.

For that guarantee of origin, which constitutes the essential function of a trademark, to be ensured, the proprietor must be protected against competitors wishing to take unfair advantage of the status and reputation of the trademark by selling products illegally bearing it.

The preamble to the Directive [cf Art. 16.1 of TRIPS] points out the absolute nature of the protection afforded by the trademark in the case of identity between the mark and the sign and between the goods or services concerned and those for which the mark is registered. It follows that the exclusive right was conferred in order to enable the trademark proprietor to protect his specific interests as proprietor, that is, to ensure that the trademark can fulfill its functions.

The exercise of that right must therefore be reserved to cases in which a third party's use of the sign affects or is liable to affect the functions of the trademark, in particular its essential function of guaranteeing to consumers the origin of the goods.

The proprietor may not prohibit the use of a sign identical to the trademark for goods identical to those for which the mark is registered if that use cannot affect his own interests as proprietor of the mark, having regard to its functions. Thus certain uses for purely descriptive purposes are excluded from the scope of [protection] because they do not affect any of the interests which that provision aims to protect, and do not therefore fall within the concept of use within the meaning of that provision.

It is immaterial that, in the context of that use, the sign is perceived as a badge of support for or loyalty or affiliation to the trademark proprietor.

The case was referred back to the national court, which eventually found against Reed.¹¹²

112 *Arsenal Football Club v Reed* [2003] EWCA 696 [UK]. See for a different aspect of trademark use: *The Rugby Football Union v Cotton Traders Ltd* [2002] EWHC 467 [UK]; *SA Football Association v Stanton Woodrush (Pty) Ltd* [2002] ZASCA 142 [South Africa].

F. THE USE OF ADDITIONAL MATTER

21. Identifying the defendant's trademark: Before it is possible to compare the junior mark with the registered trademark it is necessary to establish what trademark the defendant is using: is he using the mark as a trademark to indicate origin or does he use it for other purposes?¹¹³ To explain the difference: the trademark *Penguin* for books does not imply that no one may publish a book with the word "penguin" as part of its title, such as *The Book of Penguins* or *The Story of a Penguin* or even "Penguins" because in these instances the word penguin is being used in a descriptive manner to describe the particular book or its contents, and not its origin.

R v JOHNSTONE

[2003] UKHL 28 [UK]

If a magazine publisher were to register an ordinary question mark, "?", as a trademark for magazines this would not prevent the grammatical use of question marks on the covers of other magazines.

MOTHERCARE UK LTD v PENGUIN BOOKS

[1988] RPC 113 [UK]

It stands to reason that a Trademarks Act would only be concerned to restrict the use of a mark as a trademark or in a trademark sense, and should be construed accordingly. If descriptive words are legitimately registered [as a trademark], there is still no reason why other people should not be free to use the words in a descriptive sense, and not in any trademark sense.

22. The added matter fallacy: Once the defendant's mark has been identified it is impermissible to denude it by removing all additional material that differentiates it from the plaintiff's trademark, thereby bringing it closer to the latter. The "added matter" doctrine does not permit a-contextual examination of the accused sign because it is highly artificial to compare the accused mark through the eyes of the average consumer without considering what impact the overall use of the sign "in context" would have upon him.¹¹⁴ In this regard it is necessary to place the following dictum taken from the case next quoted in context, namely that –

The statutory protection is absolute in the sense that once a mark is shown to offend, the user of it cannot escape by showing that

¹¹³ *Apple Corps Ltd v Apple Computer Inc* [2006] EWHC 996 [UK].

¹¹⁴ Paraphrasing *O2 Holdings Ltd v Hutchison 3G Ltd* [2006] EWHC 534 (Ch).

by something outside the actual mark itself he has distinguished his goods from those of the registered proprietor.

The court added

SAVILLE PERFUMERY LTD v JUNE PERFECT LTD

(1941) 58 RPC 147

Once it is found that the defendant's mark is used as a trademark, the fact that he makes it clear that the commercial origin of the goods indicated by the trademark is some business other than that of the plaintiff avails him nothing, since infringement consists in using the mark as a trademark, that is, as indicating origin.

The issue can be illustrated with reference to the facts of *The Polo/Lauren Co LP v Shop In Department Store Pte Ltd* [2005] SGHC 175, [2005] 4 SLR 816 (Singapore High Court). The oft litigated registered trademark "Polo" for clothing was in issue. The question was whether it was infringed by the mark "Polo Pacific". The court rejected the argument that the word "Pacific" should be regarded as added matter under the *Saville* dictum and did not compare "Polo" with "Polo" but rather "Polo Pacific" with "Polo". Likewise, *10 Royal Berkshire Polo Club Trademark* [2001] RPC 32 held that the mark "10 Royal Berkshire Polo Club" was not identical or confusingly similar to "Polo". On the other hand, *Polo Textile Industries Pty Ltd v Domestic Textile Corporation Pty Ltd* (1993) 42 FCR 227, (1993) 26 IPR 246 held that "Polo Club" infringed "Polo". The legal principle appears from this extract:

O2 HOLDINGS LTD v HUTCHISON 3G LTD

[2006] EWCA Civ 1656 [UK]

There is no good reason to say that the consideration [for infringement] is limited to a comparison between the defendant's sign with the registered mark. Indeed the very Article clearly calls for an examination of the context of the use – you have to consider how the defendant is using the sign complained of to answer the basic question of whether he is using it "in the course of trade". So it is particularly artificial then to go on to try to isolate the sign of which complaint is made devoid from the context of its use.

The facts of the following case illustrate the principle further. The senior mark, TREAT, was registered for dessert sauces and syrups in Class 30. The defendant produced a toffee-flavored spread. The key wording on the label was "Robertson's Toffee Treat" coupled with a description "Irresistibly rich

toffee spread". "Robertson's" is in clear white capital lettering. "Toffee Treat" is in a fancy script. "Toffee" is at least twice the size of "Treat". The question here discussed was whether the additions of the words "Robertson's" and "Toffee" meant that the senior mark, TREAT, was not infringement. The qualification in the final sentence of the quotation is important.

BRITISH SUGAR PLC v JAMES ROBERTSON & SONS LTD

[1996] RPC 281 [UK]

In Origins Natural Resources Inc v Origin Clothing Ltd [1995] FSR 280, I said that s. 10:

"requires the court to assume the mark of the plaintiff is used in a normal and fair manner in relation to goods for which it is registered and then to assess a likelihood of confusion in relation to the way the defendant uses its mark, discounting added matter or circumstances."

One still has to identify the defendant's sign for the purposes of the comparison. In most cases there can be no difficulty. It is either there or not. However it is possible for the sign to be hidden or swamped. No-one but a crossword fanatic, for instance, would say that "treat" is present in "theatre atmosphere". There is no question of this sort here, however. "Treat" is there on the Robertson products for all to see. Whether it is used as a trademark is quite another matter.

I am not persuaded that any of this establishes that the phrase was ever thought to be a trademark in its own right.

G. NOTIONAL USE

23. *Notional use by trademark owner:* In determining infringement regard should be had to the way the registered trademark may be used by the owner by virtue of the registration and not to how it is in fact used by the owner. This is because the rights of the owner are determined by the scope of the registration and not by its use of the trademark.

SHELL CO OF AUSTRALIA LTD v STANDARD OIL (AUSTRALIA) LTD

(1963) 109 CLR 407 [Australia]

The ultimate reference when infringement of a registered mark is in issue is the mark as registered, not the mark as used. Whether or not another mark is identical in form with a registered mark, or

so substantially identical as to be an infringement, depends upon a comparison of it with the registered mark, rather than with any variants that the owner has preferred to use in practice for an action to restrain the infringement of a trademark is essentially different from a passing-off action.

24. *Notional use by a defendant:* In judging infringement the actual use by the defendant of its mark determines whether or not it is infringing. The way the defendant notionally may use the “infringing” mark is irrelevant.

PLASCON-EVANS PAINTS LTD v VAN RIEBEECK PAINTS (PTY) LTD

1984 (3) SA 623 (A) [South Africa]

In certain of the decided cases it has been held that the court should include in its comparison what has been termed the “notional use” of the registered mark and of the alleged infringing mark, which means that in making the necessary comparison the court is not confined to the manner in which the parties have actually used their respective marks: it may have regard to how they can use the marks in a fair and normal manner. I can well see that in considering the question of infringement the court should have regard not only to the plaintiff’s actual use of his registered mark, but also to notional use, that is to all possible fair and normal applications of the mark within the ambit of the monopoly created by the terms of the registration. I have some difficulty, however, in applying the notional user approach to the use by the defendant of his mark, especially as regards the type of goods to which the mark is applied.

TRADEMARKS: CONFUSION

CHAPTER IV

- A. THE RELEVANCE AND MEANING OF CONFUSION (1-2)
- B. WHO MUST BE CONFUSED? (3-7)
- C. GLOBAL APPRECIATION (8-14)
- D. FACTORS USED IN ASSESSING LIKELIHOOD OF CONFUSION (15-19)
- E. SIMILARITY IN SIGHT, SOUND AND MEANING (20)
- F. VISUAL SIMILARITY (21)
- G. SIMILARITY IN SOUND (22-24)
- H. CONCEPTUAL SIMILARITY (25)
- I. INTENTION TO CAUSE CONFUSION (26-27)
- J. PROOF OF (LIKELIHOOD OF) CONFUSION (28-29)

A. THE RELEVANCE AND MEANING OF CONFUSION

1. *Confusion and deception*: This chapter deals with the element of confusion. It will be recalled that confusion is a requirement for secondary trademark infringement because a person infringes a registered trademark if (for, example, in terms of the UK laws) he uses in the course of trade a sign where because:

- the sign is identical with the trademark and is used in relation to goods or services similar to those for which the trademark is registered, or
- the sign is similar to the trademark and is used in relation to goods or services identical with or similar to those for which the trademark is registered,

there exists a likelihood of confusion on the part of the public, which includes the likelihood of association with the trademark.¹¹⁵

Some trademark acts speak of the likelihood of confusion or deception. Those that, in line with TRIPS, speak only of confusion do not increase or reduce the level of protection. Although the words have different dictionary meanings (deception means to cause someone to believe something that is false and confusion means to cause bewilderment, doubt or uncertainty), they have usually been employed synonymously and interchangeably in this context.¹¹⁶

PIONEER HI-BRED CORN COMPANY v HY-LINE CHICKS PTY LTD

[1978] 2 NZLR 50 [New Zealand]

Deceived implies the creation of an incorrect belief or mental impression and causing *confusion* may go no further than perplexing or mixing up the minds of the purchasing public. Where the deception or confusion alleged is as to the source of the goods, deceived is equivalent to being misled in not thinking that the goods, bearing the name of the applicant's mark come from some other source and confused to being caused to wonder whether that might not be the case.

2. *Likelihood of confusion may include the likelihood of association*: The likelihood of confusion on the part of the public includes, in terms of some laws, the likelihood of association of the infringing sign with the registered trademark.

115 ECJ, 18 December 2008, *Éditions Albert René / OHIM (Obelix / Mobilix)*, C-16/06 P, ECR 2008, I-10053.

116 *Cadila Health Care Ltd Cadila Pharmaceuticals Ltd* AIR 2001 SC 1952 [India]; *Boswell-Wilkie Circus v Brian Boswell Circus* 1984 (1) SA 734 (N) [South Africa].

SMITHKLINE BEECHAM PLC v ANTIGEN PHARMACEUTICALS LTD

[1999] IEHC 144 [Ireland]

The concept [of the likelihood of association] itself comes from article 4(1)(b) of the [EC] Directive and apparently derived from Benelux case law. In the case of *Union v Union Soleure* (1984) BIE 137 it was stated:

“There is similarity between a trademark and a sign when, taking into account the particular circumstances of the case, such as the distinctive power of the trademark, the trademark and the sign, each looked at as a whole and in relation to one another, demonstrate such [audial], visual or conceptual resemblance, that associations between sign and trademark are evoked merely on the basis of this resemblance.”

SABEL BV v PUMA AG, RUDOLF DASSLER

ECJ, 11 November 1997, C-251/95, ECR 1997, I-6191:

The provision is designed to apply only if, by reason of the identity or similarity both of the marks and of the goods or services which they designate, ‘there exists a likelihood of confusion on the part of the public, which includes the likelihood of association with the earlier trademark’. It follows from that wording that the concept of likelihood of association is not an alternative to that of likelihood of confusion, but serves to define its scope. The terms of the provision itself exclude its application where there is no likelihood of confusion on the part of the public.

B. WHO MUST BE CONFUSED?

3. *The average consumer must be confused:* A rule of long standing requires that the class of persons who are likely to be the consumers of the goods or services in question must be taken into account in determining whether there is a likelihood of confusion. The problem is that it is not always possible to classify the consumers of particular products or services because they are consumed or used by members of many or all sectors of the population, irrespective of level of literacy or sophistication. The notional consumer may therefore be as elusive as the reasonable person and is unlikely to be found on any suburban bus.

SABEL BV v PUMA AG, RUDOLF DASSLER

ECJ, 11 November 1997, C-251/95, ECR 1997, I-6191:

The wording that ‘there exists a likelihood of confusion on the part of the public’ shows that the perception of marks in the mind of the average consumer of the type of goods or services in question plays a decisive role in the global appreciation of the likelihood of confusion. The average consumer normally perceives a mark as a whole and does not proceed to analyze its various details.

4. *A specialized market*: If the market is specialized, such as with prescription drugs, the typical prescribing doctor and pharmacists must be considered.¹¹⁷

“The consumer, we are led to believe, is the measure of all things in trademark law. Trademarks exist only to the extent that consumers perceive them as designations of source. Infringement occurs only to the extent that consumers perceive one trademark as referring to the source of another. The most ‘intellectual’ of the intellectual properties, trademarks are a property purely of consumers’ minds.

Trademark law is arguably the most difficult of the intellectual property laws to contemplate, and its outcomes when applied to facts are the most difficult to predict. This is because it requires a form of what John Keats called ‘negative capability’, the capability, more specifically, to think *through* the consumer and see the marketplace only as the consumer sees.”

5. *The attentive buyer*: Depending on the product, the public may be more attentive and discerning.

CLAUDE RUIZ-PICASSO v OHIM AND DAIMLERCHRYSLER AG

ECJ, 12 January 2006, C-361/04 P, ECR 2006, I-643:

Therefore, the Court of First Instance was fully entitled to hold that, for the purposes of assessing whether there is any likelihood of confusion between marks relating to motor vehicles, account must be taken of the fact that, in view of the nature of the goods concerned and in particular their price and their highly technological character, the average consumer displays a particularly high level of attention at the time of purchase of such goods.

117 Barton Beebe *Search and Persuasion in Trademark Law* [103] *Michigan Law Review* 2020.

Where it is established in fact that the objective characteristics of a given product mean that the average consumer purchases it only after a particularly careful examination, it is important in law to take into account that such a fact may reduce the likelihood of confusion between marks relating to such goods at the crucial moment when the choice between those goods and marks is made.

6. *Reasonable consumer*: The average consumer must be presumed to be reasonably well-informed and reasonably observant.

LLOYD SCHUFABRIK MEYER & CO GmbH v KLIJSEN HANDEL BV

ECJ, 22 June 1999, C-342/97, ECR 1999, I-3819:

In addition, the global appreciation of the likelihood of confusion must, as regards the visual, aural or conceptual similarity of the marks in question, be based on the overall impression created by them, bearing in mind, in particular, their distinctive and dominant components.

The average consumer normally perceives a mark as a whole and does not proceed to analyze its various details.

For the purposes of that global appreciation, the average consumer of the category of products concerned is deemed to be reasonably well-informed and reasonably observant and circumspect. However, account should be taken of the fact that the average consumer only rarely has the chance to make a direct comparison between the different marks but must place his trust in the imperfect picture of them that he has kept in his mind. It should also be borne in mind that the average consumer's level of attention is likely to vary according to the category of goods or services in question.

7. *Substantial number of consumers*: The onus rests on the trademark owner to prove that a substantial number of persons will probably be confused.

PLASCON-EVANS PAINTS LTD v VAN RIEBEECK PAINTS (PTY) LTD

1984 (3) SA 623 (A) [South Africa]

In an infringement action the onus is on the plaintiff to show the probability or likelihood of deception or confusion. It is not incumbent upon the plaintiff to show that every person interested or concerned (usually as customer) in the class of goods for which his trademark has been registered would probably be deceived or confused. It is sufficient if the probabilities establish that a substantial number of such persons will be deceived or confused.

The concept of deception or confusion is not limited to inducing in the minds of interested persons the erroneous belief or impression that the goods in relation to which the defendant's mark is used are the goods of the proprietor of the registered mark, i.e. the plaintiff, or that there is a material connection between the defendant's goods and the proprietor of the registered mark; it is enough for the plaintiff to show that a substantial number of persons will probably be confused as to the origin of the goods or the existence or non-existence of such a connection.

PIONEER HI-BRED CORN COMPANY v HY-LINE CHICKS PTY LTD

[1978] 2 NZLR 50 [New Zealand]

The test of likelihood of deception or confusion does not require that all persons in the market are likely to be deceived or confused. But it is not sufficient that someone in the market is likely to be deceived or confused. A balance has to be struck. Terms such as 'a number of people', 'a substantial number of people', 'any considerable section of the public', and 'any significant number of such purchasers' have been used. As Cooke J put it:

'That varying terminology in the judgments is a reminder that it is not always necessary that a large number of people should be, or should probably be, of the state of mind in question; rather it is a question of the significance of the numbers in relation to the market for the particular goods.'

C. GLOBAL APPRECIATION

8. *The trademark must be considered as a whole:* The general trend in considering trademark infringement is to apply the global appreciation test. Rights in trademarks exist in the entire mark as registered and not as segmented or dissected because "it is a fallacy to break the faggot stick by stick"¹¹⁸ and "legal surgery, in which trademarks have parts enhanced or discarded, is of little value in determining the effect of design marks on purchasers who merely recollect."¹¹⁹

This does not mean that the dominant feature of a trademark does not play a role in determining the likelihood of confusion. On the contrary, it plays an important part.

118 *Joseph Schlitz Brewing Co v Houston Ice And Brewing Co* 250 US 28 (1919) per Holmes J.

119 *Grandpa Pidgeon's of Missouri Inc v Borgsmiller* 447 F2d 586.

DECISION OF MAY 11, 2006 - I ZB 28/04

BGH [Germany]

According to long-standing BGH precedent, all circumstances must be thoroughly considered in determining whether there is a risk of confusion in a particular case. This consideration must take account of any identity or similarity between the products or services, the degree of similarity between the marks and the distinctiveness of the mark that holds the priority of time, and must take into account the fact that a lesser degree of similarity between products or services may be offset by a greater degree of similarity between marks or by the greater distinctiveness of the older mark, and *vice versa*.

The question of similarity between opposing marks is to be judged according to their similarity of sound, image/text and meaning/content, as marks can influence the groups at whom they are targeted through sound, image and content.

The evaluation of similarity between opposing marks to determine the presence of a risk of confusion is to be conducted by considering each of the marks in question as a whole and comparing the overall impressions created by each of them. This does not mean that, under certain circumstances, one or more of the components of a composite mark may not be the defining characteristic for the overall impression created in the minds of the groups targeted by the mark. Nor does it rule out that an indication incorporated as one element of a composite mark or a complex identification may independently have distinctive status even without dominating or defining the appearance of that composite mark or complex identification. If this independently distinctive component is identical or similar to a mark that is older and which is registered, or for which registration has been requested, this may confirm the presence of a risk of confusion, since the impression may be created among the target groups that the products or services in question came from companies that are, at the very least, commercially linked to one another.

9. *The global appreciation involves sight, sound and concept:***SABEL BV v PUMA AG, RUDOLF DASSLER**

ECJ, 11 November 1997, C-251/95, ECR 1997, I-6191:

The appreciation of the likelihood of confusion 'depends on numerous elements and, in particular, on the recognition of the trademark on the market, of the association which can be made with the used or

registered sign, of the degree of similarity between the trademark and the sign and between the goods or services identified'. The likelihood of confusion must therefore be appreciated globally, taking into account all factors relevant to the circumstances of the case.

That global appreciation of the visual, aural or conceptual similarity of the marks in question must be based on the overall impression given by the marks, bearing in mind, in particular, their distinctive and dominant components. The wording that 'there exists a likelihood of confusion on the part of the public' shows that the perception of marks in the mind of the average consumer of the type of goods or services in question plays a decisive role in the global appreciation of the likelihood of confusion. The average consumer normally perceives a mark as a whole and does not proceed to analyze its various details.

In that perspective, the more distinctive the earlier mark, the greater will be the likelihood of confusion.

THE COURT OF LAW OF THE ANDINE COMMUNITY

Case No 194-IP-2006

Similarity between two signs can exist because of several reasons:

Orthographic similarity exists when there is a similarity between the letters of the signs, when the succession of the vowels, the length of the word or words, the number of syllables, the identical roots or terminations can increase confusion. Similarity between signs is determined by the existence of identical vowels placed in the same order.

Phonetic similarity exists when there are similar roots and termination and when the tonic syllable of the two names is identical or very difficult to distinguish. It must be added that in order to establish the existence of a potential confusion, the particulars of each case must be taken into account.

Ideological similarity exists between signs which evoke an identical or similar idea.

Since the main function of a trademark is to distinguish or identify a product or service on the market, it is desirable that signs requiring registration are not similar or identical to signs which are already registered or requested to be registered as trademarks, in order to

avoid confusing the consumers and protect the exclusive use right of the trademark's owner in advance.

10. *The interdependence of the relevant factors:*

CANON KABUSHIKI KAISHA v METRO-GOLDWYN-MAYER INC

ECJ, 29 September 1998, C-39/97, ECR 1998, I-5507

MGM applied for the registration of the word trademark CANNON to be used in respect of films recorded on videotape cassettes (video film cassettes). CKK opposed that application on the ground that it would infringe its earlier word trademark CANON, registered in respect of still and motion picture cameras and projectors. The national court had found that although CANNON and CANON are pronounced in the same way and the mark CANON has a reputation, the public perception is that 'films recorded on video tape cassettes (video film cassettes)' and 'recording and reproduction devices for video tapes (video recorders)' do not come from the same manufacturer, which meant that the two marks could exist alongside each other.¹²⁰ The judgment of the ECJ in effect upheld the correctness of the finding.

A global assessment of the likelihood of confusion implies some interdependence between the relevant factors, and in particular a similarity between the trademarks and between these goods or services. Accordingly, a lesser degree of similarity between these goods or services may be offset by a greater degree of similarity between the marks, and vice versa.

Furthermore the more distinctive the earlier mark, the greater the risk of confusion. Since protection of a trademark depends on there being a likelihood of confusion, marks with a highly distinctive character, either *per se* or because of the reputation they possess on the market, enjoy broader protection than marks with a less distinctive character.

The distinctive character of the earlier trademark, and in particular its reputation, must be taken into account when determining whether the similarity between the goods or services covered by the two trademarks is sufficient to give rise to the likelihood of confusion.

There is a likelihood of confusion where the public can be mistaken as to the origin of the goods or services in question.

120 This is a factual finding and the perception may differ from jurisdiction to jurisdiction and from time to time.

Accordingly, the risk that the public might believe that the goods or services in question come from the same undertaking or, as the case may be, from economically-linked undertakings, constitutes a likelihood of confusion. Consequently, in order to demonstrate that there is no likelihood of confusion, it is not sufficient to show simply that there is no likelihood of the public being confused as to the place of production of the goods or services.

11. *The classic common-law test:* The following test has been applied in numerous cases.¹²¹

THE PIANOTIST COMPANY LTD

(1906) 23 RPC 774 [UK]

You must take the two words [or marks]. You must judge of them, both by their look and by their sound. You must consider the goods to which they are to be applied. You must consider the nature and kind of customer who would be likely to buy those goods. In fact, you must consider all the surrounding circumstances; and you must further consider what is likely to happen if each of those trademarks is used in a normal way as a trademark for the goods of the respective owners of the marks. If, considering all those circumstances, you come to the conclusion that there will be a confusion—that is to say, not necessarily that one man will be injured and the other will gain illicit benefit, but that there will be a confusion in the mind of the public which will lead to confusion in the goods—then you may refuse the registration, or rather you must refuse the registration in that case.

12. *Diverging opinion on the global assessment test:* Not all jurisdictions are comfortable with the global appreciation approach because it may not fit in with their legislative scheme.

THE POLO/LAUREN CO LP v SHOP IN DEPARTMENT STORE PTE LTD

[2005] SGHC 175 [Singapore]

There are two reasons why I reject the global assessment test. First, the global assessment test is not *in pari materia* with our legislation and, in fact, confuses the elements of infringement required under s 27(2) (b) of the TMA. It is clear from the plain words of s 27(2) (b) that the likelihood of confusion, if any, must be the direct result

¹²¹ *Eg Cooper Engineering Co Pty Ltd v Sigmund Pumps Ltd* (1952) 86 CLR 536 (HCA) [Australia]. The respondent's goods were goods of the same description (irrigation equipment) as the appellant's goods, and the sole question was whether the word RAINMASTER so resembled the word RAIN KING as to be likely to deceive. The Court found that there was no such likelihood. See also *Pepsico Inc v Hindustan Coca Cola* 2001 PTC 699 [India].

of the similarity between the registered mark and the disputed sign and between the goods and services used in relation thereto. The provision does not make it an infringement if the likelihood of confusion is caused by some other factor. Neither does it make similarity merely one among other factors that may be considered.¹²² This is obviously sound because the TMA protects the proprietary rights of the owner's trade mark and nothing else. This conceptual clarity is lost if we adopt the global assessment test which takes as its ultimate test the question of whether there is a likelihood of confusion.

Second, under the global assessment test approach, because the likelihood of confusion is the ultimate test for infringement, other factors such as the distinctiveness and the reputation of the first trade mark would decide the issue. The greater the distinctiveness of the earlier mark, the greater the likelihood of confusion. Therefore if we are not careful to separate the elements required, a strong mark would get protection for a greater range of goods than a weak mark even though the goods under consideration are vastly different and dissimilar. This does not seem either fair or sensible. If infringement is to be made out, it should be on the basis of the identity or similarity of the sign to the registered mark and the goods applied thereto.

I should add that while the global assessment test should be rejected, the cases that have followed this approach contain useful dicta particularly in respect of how the court should approach the question of whether two marks are similar.

However, while the global assessment test should be rejected, I am equally uncomfortable with a strict adherence to old English jurisprudence. In particular, both parties appeared to agree that the test for the likelihood of confusion under this approach is an exceedingly narrow one.

13. *A close analysis of the marks in question should be avoided:*

VEUVE CLICQUOT PONSARDIN v BOUTIQUES CLICQUOT LTÉE

2006 SCC 23 [Canada]

The test to be applied is a matter of first impression in the mind of a casual consumer somewhat in a hurry who sees the name *Clicquot* on the respondents' storefront or invoice, at a time when he or she

¹²² It is debatable whether the Court's understanding of the global appreciation test as reflected in these two sentences was correct.

has no more than an imperfect recollection of the VEUVE CLICQUOT trademarks, and does not pause to give the matter any detailed consideration or scrutiny, nor to examine closely the similarities and differences between the marks.

CADILA HEALTH CARE v CADILA PHARMACEUTICALS

AIR 2001 SC 1952 [India]

An unwary purchaser of average intelligence and imperfect recollection would not, as the High Court supposed, split the name into its component parts and consider the etymological meaning thereof or even consider the meaning of the composite words as 'current of nectar' or 'current of Lakshman' [an important *persona* in Hindu religion]. He would go more by the overall structural and phonetic similarity and the nature of the medicine he has previously purchased, or has been told about, or about which has otherwise learnt and which he wants to purchase. Where the trade relates to goods largely sold to illiterate or badly educated persons, it is no answer to say that a person educated in the Hindi language would go by the etymological or ideological meaning and see the difference between 'current of nectar' and 'current of Lakshman'.

LABORATOIRE LACHARTRE SA v ARMOUR-DIAL INC

1976 (2) SA 744 (T) [South Africa]

We have had the benefit of written reasons from the Registrar [of Trademarks] and argument from counsel. We have had ample time for full consideration and close comparison of the two trademarks. These advantages, however, carry their own dangers. They have caused us to look at the trademarks with far greater care than they would be looked at by the members of the public whose probable reactions we are required to assess, and with a far keener awareness of similarities and dissimilarities than such people would probably have as they go about their daily lives.

What we have now to do is, therefore, to transport ourselves, notionally, from the courtroom or the study, to the market place. We must try to look at the marks as they will be seen, if they are both in fair and normal commercial use, by the hypothetical consumers of toilet articles. Those will be people of many races and degrees of education, having varied gifts, interests and talents. We are not to postulate the consumer of 'phenomenal ignorance or extraordinary intelligence'. We are to consider a person of average intelligence and proper eyesight, buying with ordinary caution.

14. *Highly distinctive marks have wider protection than those that have a lesser degree of distinctiveness:*

LLOYD SCHUFABRIK MEYER & CO GmbH v KLIJSEN HANDEL BV

ECJ, 22 June 1999, C-342/97, ECR 1999, I-3819:

There may be a likelihood of confusion, notwithstanding a lesser degree of similarity between the trademarks, where the goods or services covered by them are very similar and the earlier mark is highly distinctive.

In determining the distinctive character of a mark and, accordingly, in assessing whether it is highly distinctive, the court must make an overall assessment of the greater or lesser capacity of the mark to identify the goods or services for which it has been registered as coming from a particular undertaking, and thus to distinguish those goods or services from those of other [undertakings].

In making that assessment, account should be taken, in particular, of the inherent characteristics of the mark, including the fact that it does or does not contain an element descriptive of the goods or services for which it has been registered; the market share held by the mark; how intensive, geographically widespread and long-standing use of the mark has been; the amount invested by the undertaking in promoting the mark; the proportion of the relevant section of the public which, because of the mark, identifies the goods or services as originating from a particular undertaking; and statements from chambers of commerce and industry or other trade and professional associations.

D. FACTORS USED IN ASSESSING LIKELIHOOD OF CONFUSION

15. *List of factor to consider.* Courts utilize a number of factors to assess the likelihood of confusion. All these factors are not necessarily relevant in any particular case but a checklist is nevertheless useful. The factors have been framed in different ways by different courts.¹²³

VEUVE CLICQUOT PONSARDIN v BOUTIQUES CLIQUOT LTÉE

2006 SCC 23 [Canada]

In every case, the factors to be considered when making a determination as to whether or not a trade-mark is confusing to the somewhat-

123 Suzy A Frankel *A tale of confusion: how tribunals treat the presence and absence of evidence of actual confusion in trade mark matters* [2001] *VUWL*Rev 5.

hurried consumer 'in all the circumstances' include, but are not limited to, those enumerated in s. 6(5) of the Act. These are:

- the inherent distinctiveness of the trademarks or trade-names and the extent to which they have become known;
- the length of time the trademarks or trade-names have been in use;
- the nature of the wares, services or business;
- the nature of the trade; and
- the degree of resemblance between the trademarks or trade-names in appearance or sound or in the ideas suggested by them.

The list of circumstances is not exhaustive and different circumstances will be given different weight in a context-specific assessment.

INTERPACE CORPORATION v LAPP INC

721 F.2d 460 [USA]

The law of trademark protects trademark owners in the exclusive use of their marks when use by another would be likely to cause confusion. Where the trademark owner and the alleged infringer deal in competing goods or services, the court need rarely look beyond the mark itself. In those cases the court will generally examine the registered mark, determine whether it is inherently distinctive or has acquired sufficient secondary meaning to make it distinctive, and compare it against the challenged mark. To determine likelihood of confusion where the plaintiff and defendant deal in non-competing lines of goods or services, the court must look beyond the trademark to the nature of the products themselves, and to the context in which they are marketed and sold. The closer the relationship between the products, and the more similar their sales contexts, the greater the likelihood of confusion.

Over the years the courts have identified a number of factors to aid in determining likelihood of confusion in non-competing products cases. Those factors are:

- the degree of similarity between the owner's mark and the alleged infringing mark;
- the strength of the owner's mark;
- the price of the goods and other factors indicative of the care and attention expected of consumers when making a purchase;
- the length of time the defendant has used the mark without evidence of actual confusion arising;

- the intent of the defendant in adopting the mark;
- the evidence of actual confusion;
- whether the goods, though not competing, are marketed through the same channels of trade and advertised through the same media;
- the extent to which the targets of the parties' sales efforts are the same;
- the relationship of the goods in the minds of consumers because of the similarity of function;
- other facts suggesting that the consuming public might expect the prior owner to manufacture a product in the defendant's market, or that he is likely to expand into that market.

16. *The lists are not mechanical checklists:*

ELI LILLY & CO v NATURAL ANSWERS INC

233 F.3d 456 [USA]

These factors are not a mechanical checklist, and 'the proper weight given to each will vary from case to case.' At the same time, although no one factor is decisive, the similarity of the marks, the intent of the defendant, and evidence of actual confusion are the most important considerations.

17. *The effect of the dominant features of the marks on the assessment:*

PLASCON-EVANS PAINTS LTD v VAN RIEBEECK PAINTS (PTY) LTD

1984 (3) SA 623 (A) [South Africa]

The determination of these questions involves essentially a comparison between the mark used by the defendant and the registered mark and, having regard to the similarities and differences in the two marks, an assessment of the impact which the defendant's mark would make upon the average type of customer who would be likely to purchase the kind of goods to which the marks are applied. This notional customer must be conceived of as a person of average intelligence, having proper eyesight and buying with ordinary caution.

The comparison must be made with reference to the sense, sound and appearance of the marks. The marks must be viewed as they would be encountered in the market place and against the background of relevant surrounding circumstances. The marks must not only be considered side by side, but also separately. It must be borne in mind that the ordinary purchaser may encounter goods, bearing the

defendant's mark, with an imperfect recollection of the registered mark and due allowance must be made for this.

If each of the marks contains a main or dominant feature or idea the likely impact made by this on the mind of the customer must be taken into account. As it has been put, marks are remembered rather by general impressions or by some significant or striking feature than by a photographic recollection of the whole. And finally consideration must be given to the manner in which the marks are likely to be employed as, for example, the use of name marks in conjunction with a generic description of the goods.

18. *Imperfect recollection*:¹²⁴

AUSTRALIAN WOOLLEN MILLS LTD v FS WALTON & CO LTD

(1937) 58 CLR 641 (HCA) [Australia]

In deciding this question, the marks ought not, of course, to be compared side by side. An attempt should be made to estimate the effect or impression produced on the mind of potential customers by the mark or device for which the protection of an injunction is sought. The impression or recollection, which is carried away and retained, is necessarily the basis of any mistaken belief that the challenged mark or device is the same. The effect of spoken description must be considered. If a mark is in fact or from its nature likely to be the source of some name or verbal description by which buyers will express their desire to have the goods, their similarities both of sound and of meaning may play an important part. The usual manner in which ordinary people behave must be the test of what confusion or deception may be expected. Potential buyers of goods are not to be credited with any high perception or habitual caution. On the other hand, exceptional carelessness or stupidity may be disregarded. The course of business and the way in which the particular class of goods are sold gives, it may be said, the setting, and the habits and observation of men considered in the mass affords the standard. Evidence of actual cases of deception, if forthcoming, is of great weight.

124 See also *Shell Co of Australia Ltd v Esso Standard Oil (Australia) Ltd* (1963) 109 CLR 407(HC).

19. *Service marks are somewhat different:*

PPI MAKELAARS v PROFESSIONAL PROVIDENT SOCIETY OF SA

1998 (1) SA 595 (SCA)

[After having quoted *Plascon Evans*, quoted earlier, the judgment proceeds.] This dictum deals with goods and not service marks, the subject of the present case. The latter marks are inherently different: services are ephemeral; they are often concerned with the provision of trade-marked products of third parties; they are not offered side by side enabling customers to make instant comparisons; quality control is difficult, if not absent. In addition, service marks such as those relating to vague topics like financial services are more indefinite than goods marks relating to, say, clothing. For these reasons, it seems to me, that it is fair to assume that, in a case like this, the likelihood of confusion may more easily be established than in a comparable goods mark case.

E. SIMILARITY IN SIGHT, SOUND AND MEANING

20. *The relative value of the factors:* The relative value of sight, sound and meaning is well explained by the authors Pattishall, Hilliard and Welch:¹²⁵

“Similarity of appearance has always been the paramount criterion in determining the likelihood of confusion. If anything, its importance has been augmented in recent decades by the impact of television, mass media advertising and self-service marketing.

Generally, similarity of sound has been accorded less weight by the courts and less attention by infringers. Even in a visual and graphic age it remains a principal trade identity consideration.

The problem of similarity of connotation also raises difficult and subtle semantic questions. As with questions of appearance and pronunciation the issue in case of similar connotation remains not what is the dictionary definition but what is likely to be the understanding of an appreciable number of those who may encounter the marks.”

It should again be stressed that these matters are not judged in isolation.

MÜLHENS GMBH & CO KG v OHIM & ZIRH INTERNATIONAL CORP

ECJ, 23 March 2006, C-206/04 P, ECR 2006, I-2717

At the outset, it must be noted that the assessment of the likelihood of confusion depends on numerous elements and, in particular, on the recognition of the trade mark on the market, the association which can be made with the used or registered sign, and the degree of similarity between the trade mark and the sign and between the goods or services identified.

The existence of a likelihood of confusion on the part of the public must therefore be appreciated globally, taking into account all factors relevant to the circumstances of the case. That global assessment must, as regards the visual, aural or conceptual similarity of the marks in question, be based on the overall impression created by those marks, bearing in mind, in particular, their distinctive and dominant components

It is conceivable that the marks' phonetic similarity alone could create a likelihood of confusion. However, it must be noted that the existence of such likelihood must be established as part of a global assessment as regards the conceptual, visual and aural similarities between the signs at issue. In that regard, the assessment of any aural similarity is but one of the relevant factors for the purpose of that global assessment.

F. VISUAL SIMILARITY

21. *Confusion must be attributable to the resemblance (or otherwise) of the marks themselves and not to extraneous matter:*

NATIONAL BRANDS LTD v BLUE LION MANUFACTURING (PTY) LTD

2001 (3) SA 563 (SCA)

The appellant sold a distinctive chocolate biscuit under its registered trademark ROMANY CREAMS. The respondent sold chocolate biscuits bearing a striking resemblance under the mark ROMANTIC DREAMS. The issue was whether the respondent's use of the mark ROMANTIC DREAMS infringed the trademark ROMANY CREAMS. The dispute was confined to whether the respondent's mark so nearly resembles the registered trademark as to be likely to cause confusion. The court held that there was no infringement.

It is important to bear in mind that the likelihood (or otherwise) of deception or confusion must be attributable to the resemblance (or otherwise) of the marks themselves and not to extraneous matter. Similarities in the goods themselves or in the form in which they are presented might form the basis for an action for passing-off [unlawful competition], but that is not what is before us, and for present purposes they must be disregarded.

In my view, the marks are not likely to deceive or confuse by their sound. As for the sense of the two phrases, in my view they bear no resemblance at all. It was upon their visual appearance, however, that counsel for the appellant placed the greatest store, pointing out that the first and last five letters of both marks are identical. When those letters are highlighted, as they were in the heads of argument, the resemblance might seem impressive, but it must be borne in mind that the appellant is not likely in fair and normal use to highlight those letters at the expense of the remainder, and nor is there any suggestion that the respondent has used or will use its mark in that way. On the contrary, they are likely to be seen in the form in which the words are ordinarily written, and should be visually compared in that form.

A word mark, and particularly one that makes use of ordinary language, is not merely a combination of abstract symbols (at least to the literate observer) but is usually recognizable as a whole. In that respect, in my view, its visual appearance cannot be separated altogether from its sense. Where the sense of one word mark differs markedly from that of another (as in this case), and in particular where the registered trademark is well known, it seems to me that the scope for deception or confusion is reduced, though these are always matters of degree. In my view, the visual distinctions in the words that are in issue in this case, bearing in mind too that each immediately conjures up a different picture, are such that there is not likely to be deception or confusion.

G. SIMILARITY IN SOUND

22. *First impressions are important:*

FISONS Plc v NORTON HEALTHCARE LTD

[1994] FSR 745 [UK]

The plaintiff owned the trademark registration VICROM for eye-drops. The defendant sold a similar product under the name EYE-CROM. The

question was whether the plaintiff's mark would be pronounced as VI-CROM or VIC-ROM.

In this case it is not disputed that there is a resemblance between VICROM and EYE-CROM, particularly when spoken. Thus I must go on and consider whether there is a serious issue as to whether the resemblance is such as to be likely to lead to deception or confusion. The test is the same under s 12 as under s 4 [which dealt with registration]. Therefore the words of Luxmoore LJ, cited with approval by Viscount Maugham in *Aristoc Ltd. v Rysta Ltd* (1945) 62 RPC 65, are applicable:

'The answer to the question whether the sound of one word resembles too nearly the sound of another so as to bring the former within the limits of s 12 of the Trademarks Act 1938, must nearly always depend on first impression, for obviously a person who is familiar with both words will neither be deceived nor confused. It is the person who only knows the one word and has perhaps an imperfect recollection of it who is likely to be deceived or confused. Little assistance, therefore, is to be obtained from a meticulous comparison of the two words, letter-by-letter and syllable-by-syllable, pronounced with the clarity to be expected from a teacher of elocution. The court must be careful to make allowance for imperfect recollection and the effect of careless pronunciation and speech on the part not only of the person seeking to buy under the trade description, but also of the shop assistant ministering to that person's wants. [And then he adds a little later] The tendency to slur a word beginning with "a" is, generally speaking, very common, and the similarity between "Rysta" and "Ristoc" would, I think, be fairly obvious.'

It is the judicial ear that is decisive, but the conclusion has to be based upon all the surrounding circumstances. The defendant submitted that VICROM would be pronounced 'vic-rom'. There is no evidence to support that suggestion and I conclude that the submission cannot succeed. At the very least most people would pronounce it 'vi-crom'.

The defendant's EYE-CROM eye drops are only available on prescription. However, the evidence shows that the public ask for repeat prescriptions by name both over the telephone and when in the surgery. Such conversations take place between the public and receptionists, and the public and doctors. That being so the two marks are confusingly similar. EYE-CROM is as close in sound to VICROM as you can get without having identical marks.

GLAXO GROUP LTD v NEON LABORATORIES LTD

[2004] F.S.R. 46 (HC) [India]

Judging the marks as a matter of first impression and applying the test of an ordinary person with average intelligence and an imperfect recollection the case must be answered in the plaintiffs' favour. If the two marks TROX [the registered mark] and TREX are seen as a whole there is no doubt whatsoever that there is a likelihood of confusion in view of the deceptive similarity between the two. The substitution of the letter 'O' with the letter 'E' makes no difference. The two marks are visually and phonetically almost identical. There is a very high possibility of a mispronunciation leading a person to mistake one mark for the other. A perfect pronunciation, a clear enunciation of the words may indicate the difference. But words such as these are not always so pronounced. Moreover it is useful to mention, as has been noticed in several decisions, that words tend not to be properly enunciated and in particular the ending of words is often slurred. Even if either of the marks is pronounced correctly there is an equally high possibility of the person hearing the same to mistake one for the other. Indeed the likelihood of confusion or deception is so apparent and obvious that I find it unnecessary to enter into any detailed consideration of the law on this aspect.

23. *Degree of similarity of goods or services.* The more similar the goods or services covered and the more distinctive the earlier mark, the greater will be the likelihood of confusion.

LLOYD SCHUHFABRIK MEYER & CO GmbH v KLIJSEN HANDEL BV

ECJ, 22 June 1999, C-342/97, ECR 1999, I-3819

The question was whether the junior mark, LOINT'S, was confusingly similar to the senior mark, LLOYD, both for shoes.

[It] is possible that mere aural similarity between trademarks may create a likelihood of confusion. The more similar the goods or services covered and the more distinctive the earlier mark, the greater will be the likelihood of confusion.

24. *Multi-culturalism:* Regard should be had to multi-culturalism in the particular jurisdiction in considering the likelihood of confusion.

CORN PRODUCTS REFINING CO v SHANGRILA FOOD PRODUCTS

AIR 1960 SC 142 [India]

It is well known that the question whether the two marks are likely to give rise to confusion or not is a question of first impression. It is for the court to decide that question. English cases proceeding on the English way of pronouncing an English word by Englishmen, which it may be stated is not always the same, may not be of much assistance in our country in deciding questions of phonetic similarity. It cannot be overlooked that the word is an English word which to the mass of the Indian people is a foreign word. It is well recognized that in deciding a question of similarity between two marks, the marks have to be considered as a whole.

ALBION CHEMICAL COMPANY (PTY) LTD v FAM PRODUCTS CC

[2004] 1 All SA 194 (C)

Much was made of the fact that ALBEX and ALL BLAX are pronounced differently. In analyzing this submission it is important to bear in mind that the South African society is a multi-cultural one where many languages are spoken, and where many dialects of the same languages exist, each with its own peculiar accent. It is therefore of little assistance to consider how a person with a colonial English accent will pronounce the word without taking into consideration the various pronunciations which are encountered in this country. In view of the ever-changing demographics of our society, the differences in pronunciation should not be confined to a comparison between Cape vernacular and the so-called standard pronunciation. In this case one only has to repeat the respective marks to hear that there is a definite similarity, and that in considering the sound of the words, one must visualize conversations between people who do not necessarily articulate clearly and carefully, but have a natural tendency particularly because of language differences, to pronounce the words differently.

H. CONCEPTUAL SIMILARITY

25. *Association is not enough:* The fact that two marks are conceptually similar is not sufficient to give rise to a likelihood of confusion

SABEL BV v PUMA AG, RUDOLF DASSLER

Case C-251/95 [ECJ]

The question was the extent to which a conceptual similarity can determine whether there is a likelihood of confusion. Puma's mark was the senior mark. The Court did not answer the factual question.

It is therefore not impossible that the conceptual similarity resulting from the fact that two marks use images with analogous semantic content may give rise to a likelihood of confusion where the earlier mark has a particularly distinctive character, either per se or because of the reputation it enjoys with the public.

However, where the earlier mark is not especially well known to the public and consists of an image with little imaginative content, the mere fact that the two marks are conceptually similar is not sufficient to give rise to a likelihood of confusion.

The criterion of 'likelihood of confusion which includes the likelihood of association with the earlier mark' means that the mere association, which the public might make between two trademarks as a result of their analogous semantic content, is not in itself a sufficient ground for concluding that there is a likelihood of confusion within the meaning of that provision .

ZWILLING v ZWEIBRÜDER

BGH, Urt. v. 29 April 2004 - I ZR 191/01 [Germany]

The claimant is the owner of a well-known trademark ZWILLING (the German word for twins) for cutlery. The word twins and the graphic trademark used with the name mark consist of two identical figures holding hands. The defendant uses the trademark ZWEIBRÜDER for the same goods. The word means two brothers. The court held that the two marks can stand together.

All circumstances in the individual case must be considered in judging whether there is a risk of confusion. As part of this, the correlations between the different factors must be considered – in particular, the similarity of the indications and the similarity of the products they identify, and the distinctiveness of the older mark. In particular, a lesser degree of similarity between the indications may be offset by a greater degree of similarity between the products or the greater distinctiveness of the older mark, and *vice versa*.

The Court of Appeal considered the 'Zwilling' mark to have by far the greater distinctiveness, as it had been in intensive use over a long period and had therefore become known to the extent of practically being famous.

In determining the similarity between the opposing indications in terms of their content, the Court of Appeal employed faulty reasoning and did not take all relevant circumstances into account. The marks 'Zwilling' (meaning 'twin') and 'Zweibrüder' (meaning roughly 'two brothers') are not as close in meaning as the Court of Appeal supposed.

However, a risk of confusion does not have to be between the opposing indications themselves, but can also take the form of a risk that the contested indication will be attributed to the owner of the disputed mark on account of a partial resemblance in an essential, core area. In exceptional cases, this kind of risk of confusion can arise even when the indications bear a resemblance to each other in meaning only. However, this requires a large proportion of the public to be convinced by both content and appearance that the marks are related, since everyday experience shows that the public generally accepts indications used as marks as it finds them, without subjecting them to analytical consideration involving the potential meanings of their contents.

It is not enough to justify claims that an indication is calculated to draw attention to itself through mere association with a different trademark. Nor is it enough that the contested mark does not appear to have been chosen by chance.

COWBELL AG v ICS HOLDINGS LTD

2001 (3) SA 941 (SCA) [South Africa]

The appellant applied for the registration of the trademark COWBELL in conjunction with a cow device. The respondent, the owner of a number of trademarks in the same class, primarily directed to dairy products, opposed the application. These were DAIRY BELLE and DIARY BELLE with cow device. The registration contained an admission that cow devices are common in the foodstuff classes.

Section 17(1) creates an absolute bar to registration provided the jurisdictional fact is present, namely that the use of both marks in relation to goods or services in respect of which they are sought to be registered, and registered, would be likely to deceive or cause confusion. The decision involves a value judgment and

'[t]he ultimate test is, after all, whether on a comparison of the two marks it can properly be said that there is a reasonable likelihood of confusion if both are to be used together in a normal and fair manner, in the ordinary course of business.'

'Likelihood' refers to a reasonable probability, although the adjective 'reasonable' is perhaps surplusage. In considering whether the use of the respondent's mark would be likely to deceive cause confusion, regard must be had to the essential function of a trademark, namely to indicate the origin of the goods in connection with which it is used. Registered trademarks do not create monopolies in relation to concepts or ideas. The likelihood of confusion must 'be appreciated globally' and that the

'global appreciation of the visual, aural or conceptual similarity of the marks in question, must be based on the overall impression given by the marks, bearing in mind, in particular, their distinctive and dominant components.'

As far as the visual similarity is concerned, the court a quo held that the mark of the appellant, on the one hand, and those of the respondent, on the other, are visually so different that confusion or deception is improbable. Bovine devices are to be expected on dairy products and provide a common feature as the admissions or disclaimers testify. The cows are represented in substantially different ways. It is not necessary to elaborate since the respondent did not attack these findings.

The aural aspect was not dealt with by the court a quo in so many words as a separate inquiry. What has to be compared is then DAIRYBELL on the one hand with COWBELL on the other. Since the suffix '-le' in DAIRYBELLE is muted it may be of no audible consequence to the consumer who is unaware that the word as pronounced can refer to a dairymaid. The words 'dairy' and 'cow' bear no auditory relationship to one another. The emphasis in the respondent's mark is on the first part, which form the dominant parts of the word. 'Dairy' [is a] two-syllable word, whereas 'cow' consists of one syllable. DAIRYBELLE represents [an] unusual combinations of words and [is] in a sense [an] invented word, whereas COWBELL is an ordinary word bearing an ordinary connotation. Since the respondent did not submit that confusion or deception is likely in this context, it is unnecessary to belabour my conclusion that there is no such likelihood.

Regarding conceptual similarity, the Court a quo found that a person having heard the one mark advertised on the radio, when confronted with the other in a supermarket, will not be astute enough to discern that they are not the same or are not cows from the same herd. The concept created is that of a dairy full of cows with bells used in connection with dairy products. It reasoned that to the listener, who does not have the benefit of visual comparison, the concepts are too close for comfort.

[Section] 17(1) is concerned with a likelihood of confusion or deception and, unless the analogous semantic content can reasonably give rise thereto, it is irrelevant. The danger of confusion or deception must be real.

In short, the respondent cannot lay claim to the exclusive use of words having a dairy connotation or ending in ‘-belle’ or ‘-bel’ in relation to dairy products where these do not form a dominant part of its marks and have not any particularly distinctive character. That is why ‘Coca-Cola’ and ‘Pepsi-Cola’ have been able to exist side by side (cf *The Coca-Cola Co of Canada Ld v Pepsi-Cola Co of Canada Ld* [1942] RPC 127 (PC)).

J. INTENTION TO CAUSE CONFUSION

26. *Relevance of intention:* The intention or motive of the defendant in adopting the plaintiff’s trademark is sometimes taken into account in determining whether the defendant’s mark is confusingly similar to that of the plaintiff. The argument is that it will not be assumed that a defendant, who intended to imitate, did not succeed in its object.¹²⁶ The other view is that the subjective mental state of the defendant is irrelevant in determining whether there is confusion:¹²⁷

“Almost all of the modern decisions have shifted the emphasis away from the defendant’s subjective mental state, and have placed prime importance upon the issue of likelihood of confusion and consequent consumer deception. That is, the objective facts of probable customer confusion are more important than trying to determine what was going on in the defendant’s mind. The New York Court of Appeals stated that ‘fraud or deliberate intention to deceive or mislead the public’ is not necessary in the personal name

126 *Cadbury-Schweppes Pty Ltd v The Pub Squash Co Ltd* [1981] RPC 429 (PC) [UK].

127 McCarthy on Trademarks and Unfair Competition (4 ed) par 13.22 quoted with approval in *Advantage Group Ltd v ADV E-Commerce Ltd* [2002] NZCA 282 (CA) [New Zealand].

cases. The court concluded that: 'The bona fides of [defendant's] intentions do not change the applicable principles. The objective facts of this unfair competition and injury to plaintiff's business are determinative, not the defendant's subjective state of mind'. The California Court of Appeals stated flatly that where the junior user is using his own name, 'Actual fraud, i.e., planning or contrivance, by the junior user is not necessary'. As an Arizona court observed, if the public is likely to be confused, the injury is not alleviated by the junior user's honesty of purpose.' Both the first user and the public may be as readily wounded by the ostrich as the fox.'" [References omitted.]

27. *The intention to infringe should be distinguished from the intention to compete:*

RECKITT & COLMAN SA (PTY) LTD v S C JOHNSON & SON SA (PTY) LTD

1993 (2) SA 307 (A) [South Africa]

Reliance was also placed on the respondent's expressed intention to compete head-on with Brasso and its conscious choice of the Brasso-type tins. It was submitted that the respondent had entered the market with the deliberate intention of passing off its product as Brasso and that a court, under those circumstances, should not be astute to find that the respondent had not achieved its object. The respondent's intention in this case was to compete and an intention to compete must not be confused with an intention to deceive. The choice of the Brasso-type containers, in the light of the belief of the respondent that these containers had become generic and that the public had come to expect metal polish to be sold in containers of that general shape, was not fraudulent.

K. PROOF OF (LIKELIHOOD OF) CONFUSION

28. *Is evidence of the likelihood of confusion required or helpful?* A court, more often than not, can decide the likelihood of confusion without evidence. The two marks are simply compared and the conclusion can then be drawn whether there is such likelihood. It is improbable that evidence will convince a court one way or the other unless the evidence accords with the court's assessment. However, in the case of specialized markets, evidence may be necessary because of the special nature of the average consumer.

K AVIRAJ PANDIT DURGADUTT SHARMA v NAV R ATNA PHARMACEUTICAL LABORATORIES

AIR 1965 SC 989 [India]:

In an action for infringement, the plaintiff must, no doubt, make out that the use of the defendant's mark is likely to deceive, but where the similarity between the plaintiff's and the defendant's mark is so close either visually, phonetically or otherwise and the court reaches the conclusion that there is an imitation, no further evidence is required to establish that the plaintiff's rights are violated. Expressed in another way, if the essential features of the trademark of the plaintiff have been adopted by the defendant, the fact that the get-up, packing and other writing or marks on the goods or on the packets in which he offers his goods for sale show marked differences, or indicate clearly a trade origin different from that of the registered proprietor of the mark would be immaterial; whereas in the case of passing off, the defendant may escape liability if he can show that the added matter is sufficient to distinguish his goods from those of the plaintiff.¹²⁸

GE TRADE MARK

[1973] RPC 297 (HL) [UK]

My Lords, where goods are of a kind which are not normally sold to the general public for consumption or domestic use but are sold in a specialized market consisting of persons engaged in a particular trade, evidence of persons accustomed to dealing in that market as to the likelihood of deception or confusion is essential. A judge, though he must use his common sense in assessing the credibility and probative value of that evidence is not entitled to supplement any deficiency in evidence of this kind by giving effect to his own subjective view as to whether or not he himself would be likely to be deceived or confused.

It is difficult to visualize the type of evidence envisaged and it appears that Lord Diplock was unnecessarily modest. Evidence by a witness that he believes that he will not be confused or deceived or that he believes that he will be confused or deceived appears to have no probative value. If Lord Diplock intended to refer to evidence setting out the circumstances prevailing in the particular trade or industry the statement is unobjectionable.¹²⁹

128 As quoted in *Playboy Enterprises v Bharat Malik* 2001 PTC 328 [India].

129 *The Upjohn Co v Merck* 1987 (3) SA 221 (T) [South Africa].

29. *Evidence of actual confusion and expert and survey evidence:* Evidence of actual confusion (e.g., misdirected enquiries, complaints or mail) is valuable but seldom available. Evidence of the condition of the trade, especially if one is dealing with a specialist market, may be important.

The evidence of psychologists and linguistic experts tends to be singularly unhelpful, if not inadmissible, because in the final analysis it tends to disguise opinion as a statement of scientific principle or fact and attempts subtly to displace the court's value judgment with that of the witness.¹³⁰

Survey evidence raises two questions: the problem of getting the evidence before the court (the problem of admissibility); and the problem of the value of the survey, having regard to the way in which it was conducted (the problem of weight). As far as admissibility is concerned, it is now generally accepted that the results of a properly conducted survey are admissible (sometimes under statutory exceptions to the hearsay rule).¹³¹ As far as weight is concerned, courts have sometimes tended to approach the evidence with a degree of skepticism:

IMPERIAL GROUP PLC v PHILIP MORRIS LTD

[1984] RPC 293 [UK]

However satisfactory market research surveys may be in assisting commercial organizations as to how they can best conduct their business, they are by and large, as experience in other cases has indicated, an unsatisfactory way of trying to establish questions of fact which are likely to be matters of dispute.

TRADITION FINE FOODS LTD v OSHAWA GROUP LTD

2005 FCA 342 [Canada]

There is ample jurisprudence in which judges have given less probative value to survey evidence where such evidence was found to be unpersuasive. A judge is not bound by expert evidence and legally has the power to make the final determination. He is not substituting his views for those of the expert, but rather appreciating the evidence submitted by the expert.

130 *Reckitt & Colman SA (Pty) Ltd v S C Johnson & Son SA (Pty) Ltd* 1993 (2) SA 307 (A) [South Africa].

131 Eg New Zealand: *Customglass Boats Ltd v Salthouse Brothers Ltd* [1976] RPC 589; England: *GE Trademark Case* [1969] RPC 418 (Ch); [1970] RPC 339 (CA) and [1973] RPC 297 (HL); *Stringfellow v McCain Foods (GB) Ltd* [1984] RPC 501 (Ch D and CA); South Africa: *McDonald's Corporation v Joburgers Drive-Inn Restaurant (Pty) Ltd* 1997 (1) SA 1 (A).

MASTERPIECE INC. V. ALAVIDA LIFESTYLES INC

2011 SCC 27 [Canada]

Where parties propose to introduce expert evidence, a trial judge should question the necessity and relevance of the evidence. As I have already pointed out, if a trial judge concludes that the expert evidence is unnecessary or will distract from the issues to be decided, he or she should disallow such evidence from being introduced.

I would further suggest that it would be salutary to have a case management judge assess the admissibility and usefulness of proposed expert and survey evidence at an early stage so as to avoid large expenditures of resources on evidence of little utility.

If a survey is to have any value the questions should be fair, and they should be so formulated as to preclude a weighted or conditioned response.¹³²

132 *Hoechst Pharmaceuticals (Pty) Ltd v Beauty Box (Pty) Ltd (In Liq)* 1987 (2) SA 600 (A) [South Africa].

TRADEMARKS: WELL-KNOWN TRADEMARKS

CHAPTER V

- A. INTRODUCTION (1)
- B. PROTECTION UNDER ART. 6*BIS* OF THE PARIS CONVENTION (2-10)
- C. TRADEMARK DILUTION (11-20)

A. INTRODUCTION

1. *The scope of this chapter:* There are two types of legal protection for well-known trademarks:¹³³

- The first is based on a convention obligation created by Art. 6bis of the Paris Convention. This protection is available for a peregrine trademark owner whose trademark, even though not registered within the local jurisdiction, is well-known locally. These provisions were reinforced and extended by Art. 16.2 and 16.3 of the TRIPS Agreement.
- The second is for well-known marks registered within the jurisdiction. They may be protected against dilution without confusion. This kind of protection is optional and not obligatory under either the Paris Convention or the TRIPS Agreement.

B. PROTECTION UNDER ART 6bis OF THE PARIS CONVENTION

2. *The Paris Convention.* According to Art. 6bis(1)¹³⁴ of the Paris Convention a peregrine trademark owner whose trademark, even though not registered within the local jurisdiction, is well known locally may:

- object to the registration,
- claim cancellation, or
- prohibit the use

of a trademark that constitutes:

- a reproduction,
- an imitation, or
- a translation,

which is liable to create confusion of his trademark.

3. *Limitations inherent in Art. 6bis.* Article 6bis has a limitation: the objectionable trademark must be used for identical or similar goods. The limitation has two limbs, namely, protection is reserved for goods marks and not for service marks (service marks were not known at the time); and the protection

133 Cf. WIPO *Joint Recommendation Concerning Provisions on the Protection of Well-Known Marks* 1999.

134 "The countries of the Union undertake, *ex officio* if their legislation so permits, or at the request of an interested party, to refuse or to cancel the registration, and to prohibit the use, of a trademark which constitutes a reproduction, an imitation, or a translation, liable to create confusion, of a mark considered by the competent authority of the country of registration or use to be well known in that country as being already the mark of a person entitled to the benefits of this Convention and used for identical or similar goods. These provisions shall also apply when the essential part of the mark constitutes a reproduction of any such well-known mark or an imitation liable to create confusion therewith."

is against use for goods that are similar or identical to those of the claimant.

In order to eliminate the limitation, Art. 16.2 of TRIPS provides that the Art. 6bis protection must also be available in respect of service marks and not only to goods marks, and that it must also apply to certain dissimilar goods or services, namely (Art. 16.3) –

goods or services which are not similar to those in respect of which a trademark is registered, provided that use of that trademark in relation to those goods or services would indicate a connection between those goods or services and the owner of the registered trademark and provided that the interests of the owner of the registered trademark are likely to be damaged by such use.

4. *The exceptional nature of Art. 6bis:* These provisions form exceptions to some important trademark principles, namely those of:

- territoriality (a trademark is only effective within the jurisdiction of registration),
- specialty (trademarks protect goods and services for which they have been registered) and
- registration (registration is a prerequisite for trademark protection).¹³⁵

5. *Requirements for protection under Art. 6bis:* The requirements for protection of a foreign trademark under Art. 6bis are these:

- The owner of the foreign trademark must have a real and effective industrial or commercial establishment in a Convention country.
- A sector of the population must be “interested in the goods or services to which the mark relates”.
- The mark must be well known within the local jurisdiction as a trademark belonging to an enterprise with a base in another country.
- A substantial number of people must have the requisite knowledge.
- The local mark must constitute a reproduction, an imitation, or a translation of the foreign trademark.
- The local trademark must cause confusion.

AM MOOLLA GROUP LTD v THE GAP INC

[2005] ZASCA 72 [South Africa]

A US company began marketing clothing under the name GAP in the US during the early 1970s. More or less during the same time a local concern registered the same trademark in South Africa. The US concern became over the years one of the largest of its kind. During 1999, alleging that its trademark had become well known in South Africa, it applied for deregistration of the local concern's trademark. The claim was dismissed.

I now turn to consider whether the respondent [The Gap Inc] has made out a case for this kind of protection. Starting at the beginning, the introductory phrase of s 35(3) [of the South African Act], namely, "the proprietor of a trademark which is entitled to protection under [art 6bis of] the Paris Convention" requires that, in order to be able to obtain the protection provided for in s 35(3), the foreign owner has to be a "qualified" person in terms of s 35(1). It is common cause that since the respondent has a "real and effective industrial or commercial establishment in a convention country", this requirement has been met. Another requirement is that the claimant has to be the "proprietor" of the relevant well-known trademark in its home territory, something not disputed.

The appellants submitted that the respondent's claim based on s 35(3) was flawed because the section grants protection to a well-known mark against unregistered marks and not against marks registered locally. The existing registrations per se, according to the argument, constitute an absolute bar to s 35(3) relief. [However] article 6bis explicitly requires of countries to protect well-known marks against registered and unregistered marks. There is no apparent reason why the Legislature would have wished to provide otherwise.

The question then is whether the respondent's GAP marks are (or were) well known in South Africa and, if so, since when. This raises a number of interrelated questions which were identified during the course of E M Grosskopf JA's judgment in *McDonald's*.

The first is the identification of the sector of the population "interested in the goods or services to which the mark relates".

Next is whether the mark is well known within the local jurisdiction as a trademark belonging to an enterprise with a base in another country (although the knowledge does not have to include the fact that the country is a convention country).

The last issue is the determination of whether those who have the requisite knowledge represent a substantial number of the chosen universe.

In order to be entitled to the protection granted by s 35(3), the objectionable trademark has to constitute “a reproduction, imitation or translation of the well-known trademark” of a “qualified” party. In other words, unless the “foreign” trademark was well known at the time when the local enterprise reproduced, imitated or translated it, the foreign trademark is in the light of the principle of territoriality not entitled to Art. 6*bis* protection.

A local mark, validly appropriated, cannot lose its value or protection simply because someone else’s reputation overtakes its business.

Although the marks in contention may at first blush appear to be imitations or reproductions of the respondents’ marks, the crucial point is that when any reproduction or imitation took place, it was not of a “well-known” mark but of a mark not well known within this country. As we have seen, there is and never has been anything wrong with the reproduction or imitation of a mark that is not well known. [The local enterprise] was the first proprietor of these marks in South Africa and became the proprietor at a stage when the respondents’ marks were not yet well known.

6. *Establishing that a trademark is well known:* A practical problem that arises in this context is whether the mark must be well known to all sectors of the public or whether it will be sufficient if it is known to the relevant section of the public that has an interest in the mark. Other questions relate to the number of persons to whom the mark must have been known and how well it must have been known.

7. *The required knowledge:* The TRIPS Agreement, Art. 16.2, gives part of the answer:

In determining whether a trademark is well-known, Members shall take account of the knowledge of the trademark in the relevant sector of the public, including knowledge in the Member concerned which has been obtained as a result of the promotion of the trademark.

Article 2 of the non-binding WIPO *Joint Recommendation Concerning Provisions on the Protection of Well-Known Marks* contains useful guidelines for determining whether a mark is well-known.¹³⁶

- In determining whether a mark is a well-known mark, the competent authority must take into account any circumstances from which it may be inferred that the mark is well known.
- In particular, the competent authority must consider information submitted to it with respect to factors from which it may be inferred that the mark is, or is not, well known, including, but not limited to, information concerning the following:
 - the degree of knowledge or recognition of the mark in the relevant sector of the public;
 - the duration, extent and geographical area of any use of the mark;
 - the duration, extent and geographical area of any promotion of the mark, including advertising or publicity and the presentation, at fairs or exhibitions, of the goods and/or services to which the mark applies;
 - the duration and geographical area of any registrations, and/or any applications for registration, of the mark, to the extent that they reflect use or recognition of the mark;
 - the record of successful enforcement of rights in the mark, in particular, the extent to which the mark was recognized as well known by competent authorities;
 - the value associated with the mark.
- The above factors, which are guidelines to assist the competent authority to determine whether the mark is a well-known mark, are not pre-conditions for reaching that determination. Rather, the determination in each case will depend upon the particular circumstances of that case. In some cases all of the factors may be relevant. In other cases some of the factors may be relevant. In still other cases none of the factors may be relevant, and the decision may be based on additional factors that are not listed in subparagraph (b), above. Such additional factors may be relevant, alone, or in combination with one or more of the factors listed in subparagraph (b), above.

8. Irrelevant considerations: The mentioned *Joint Recommendation* also contains a list of factors that should not be required as a condition for determining whether a mark is a well-known mark. They are these:

- that the mark has been used in, or that the mark has been registered or that an application for registration of the mark has been filed in or in respect of, the Member State;
- that the mark is well known in, or that the mark has been

registered or that an application for registration of the mark has been filed in or in respect of, any jurisdiction other than the Member State; or

- that the mark is well known by the public at large in the Member State. (This follows from the requirement that regard should be had to the degree of knowledge or recognition of the mark in the relevant sector of the public.)

9. *China:* The Supreme People's Court of China's interpretation on issues regarding the application of the law in civil trials of unfair competition cases of 1 February 2007 provides that a commodity will be recognized as well-known if it has a market reputation in China and is well known among the relevant members of the public. In determining whether something is well known, the court will consider factors such as sales period, sales region, sales amount and sales target, and duration, extent and geographic region of promotional activity undertaken, as well as any evidence that the commodity has been recognized as a well-known commodity by the relevant authorities. The burden of proof lies with the plaintiff to establish that its commodity has the necessary market reputation.

10. *The relevant sector of the public:* Article 16.2 of the TRIPS Agreement deals with the concept of "relevant sector" of the public:

In determining whether a trademark is well-known, Members shall take account of the knowledge of the trademark in the relevant sector of the public, including knowledge in the Member concerned which has been obtained as a result of the promotion of the trademark.

Article 2 of the *Joint Recommendation* contains useful guidelines dealing with this issue in these terms:

- Relevant sectors of the public shall include, but shall not necessarily be limited to:
 - actual and/or potential consumers of the type of goods and/or services to which the mark applies;
 - persons involved in channels of distribution of the type of goods and/or services to which the mark applies;
 - business circles dealing with the type of goods and/or services to which the mark applies.
- Where a mark is determined to be well known in at least one relevant sector of the public in a Member State, the mark shall be considered by the Member State to be a well-known mark.
- Where a mark is determined to be known in at least one relevant sector of the public in a Member State, the mark may be

considered by the Member State to be a well-known mark.

- A Member State may determine that a mark is a well-known mark, even if the mark is not well known or, if the Member States applies the previous paragraph, known, in any relevant sector of the public of the Member State.

McDONALD'S CORP v JOBURGERS DRIVE-INN RESTAURANT (PTY) LTD

1997 (1) SA 1 (A) [South Africa]

McDonald's, one of the largest franchisers of fast-food restaurants in the world, had not traded nor had it used any of its trademarks in South Africa. A local company decided to establish fast-food outlets using trademarks identical to McDonald's and applied for their registration. McDonald's relied on statutory protection which was based on Art. 6*bis* of the Paris Convention. The question discussed in the following quotation concerns the level of awareness in the public mind which is required for a mark to qualify as well known. The court found that the marks were well known in South Africa. The judgment pre-dates the quoted recommendations.

The answer to [the] question [whether the mark must be well known to all sectors of the population] is, I think, clear. [The section] was intended to provide a practical solution to the problems of foreign businessmen whose marks were known in South Africa but who did not have a business here.

The South African population is a diverse one in many respects. There are wide differences in income, education, cultural values, interests, tastes, personal life styles, recreational activities, etc. This was obviously known to the Legislature when it passed the new Act. If protection is granted only to marks, which are known (not to say well known) to every segment of the population (or even to most segments of the population), there must be very few marks, if any, which could pass the test. The legislation would therefore not achieve its desired purpose. Moreover, there would not appear to be any point in imposing such a rigorous requirement. In argument we were referred as an example to a mark which might be very well known to all persons interested in golf. Why should it be relevant, when deciding whether or not to protect such a mark, that non-golfers might never have heard of it? I consider therefore that a mark is well known in the Republic if it is well known to persons interested in the goods or services to which the mark relates.

The next question then is: how well should it be known to such persons? In the present context the important practical question is

not whether a few people know the mark well but rather whether sufficient persons know it well enough to entitle it to protection against deception or confusion.

How many people are sufficient? The only guideline provided by the Legislature lies in the expression “well known”. It seems to me the Legislature intended to extend the protection of a passing-off action to foreign businessmen who did not have a business or enjoy goodwill inside the country, provided their marks were well known in the Republic. It seems logical to accept that the degree of knowledge of the marks that is required would be similar to that protected in the existing law of passing-off. The concept of a substantial number of persons is well established. It provides a practical and flexible criterion which is consistent with the terms of the statute.

These conclusions must be applied to the relevant categories among the public. Potential franchisees, I consider, would be the type of persons who would almost without exception have heard of McDonald’s and know its marks. Among potential customers the level of awareness would be lower. Many people who would be interested in buying a hamburger would not have heard of McDonald’s. However, a certain degree of financial well-being is required for the purchase of prepared food. Extremely poor people are not likely to patronize McDonald’s establishments. Of the persons who are likely to do so, at least a substantial portion must be of the category who would probably have heard of McDonald’s and know its marks, or some of them. This inference is supported by the zeal shown by Joburgers to appropriate these marks.

C. TRADEMARK DILUTION

11. *Protection of well-known registered trademarks against dilution:* There is, further, a special broad protection given to well-known registered trademarks, i.e., registered within the territory. Typical of this protection is that contained in the EU Directive and s 10(3) of the UK Trademarks Act, 1994. The EU Directive (Art. 5.2), it may be recalled, is in these terms:

Any Member State may also provide that the proprietor shall be entitled to prevent all third parties not having his consent from using in the course of trade any sign which is identical with, or similar to, the trademark in relation to goods or services which are not similar to those for which the trademark is registered, where the latter has a reputation in the Member State and where use of that sign

without due cause takes unfair advantage of, or is detrimental to, the distinctive character or the repute of the trademark.

Use of a trademark constitutes infringement where the trademark (a) is registered and (b) has a reputation within the local jurisdiction and (c) the objectionable mark takes unfair advantage of, or is detrimental to, the distinctive character or the repute of the registered trademark. These instances are usually referred to as cases of dilution, blurring or tarnishment of a trademark.

L'ORÉAL SA v BELLURE NV

ECJ, 18 June 2009, C-487/07, ECR 2009, I-5185

Article 5(2) of Directive 89/104 establishes, for the benefit of trademarks with a reputation, a wider form of protection than that laid down in Article 5(1). The specific condition of that protection consists of a use without due cause of a sign identical with or similar to a registered mark which takes or would take unfair advantage of, or is or would be detrimental to, the distinctive character or the repute of the earlier mark

Semantically, there appears to be a difference between well-known or famous trademarks and trademarks with a reputation. The ECJ, however, treats the concepts as being the same and that approach will be followed.¹³⁷

12. US law: The US Federal Trademark Dilution Act, which is another example, provides that the owner of a famous mark is entitled to an injunction against another person's commercial use of a mark or trade name, if such use begins after the mark has become famous and causes dilution of the distinctive quality of the mark.

The Act defines "dilution" as "the lessening of the capacity of a famous mark to identify and distinguish goods or services regardless of the presence or absence of competition between the owner of the famous mark and other parties or the likelihood of confusion, mistake, or deception. It also sets out a number of specific defenses, namely fair use of a famous mark by another person in comparative commercial advertising or promotion to identify the competing goods or services of the owner of the famous mark; non-commercial use of a mark; and all forms of news reporting and news commentary.

137 ECJ, 9 January 2003, *Davidoff / Gofkid*, C-292/00, ECR 2003, I-389.

13. *The purpose of the provision:*

PREMIER BRANDS UK LTD v TYPHOON EUROPE LTD

[2000] FSR 767 [UK]

The purpose of [the provision] is to provide “extensive protection to those trademarks which have a reputation”, and such protection is clearly intended to be over and above that available to marks without a reputation. As already mentioned, [it] represents a significant extension to the protection hitherto accorded to proprietors of registered trademarks in this country.

The basic principle is that a trader may not take unfair advantage of the trademark of another. This can be done in a number of ways. The principal method is by diluting the trademark through blurring or tarnishing. Confusion is not required. However, as appears from this judgment, courts are wary of granting relief under this heading. The judgment also quoted Professor J.T. McCarthy who said:

“Even the probability of dilution [or depreciation] should be proven by evidence, not just by theoretical assumptions about what possibly could occur or might happen. The courts should separate any anti-dilution claim into its discrete elements and rigorously require a showing of proof of those elements.”

VEUVE CLICQUOT PONSARDIN v BOUTIQUES CLICQUOT LTÉE

2006 SCC 23 [Canada]

Famous marks do not come in one size. Some trade-marks may be well known but have very specific associations (*Buckley’s* cough mixture is advertised as effective despite its terrible taste, not, one would think, a brand image desirable for restaurants). Other famous marks, like *Walt Disney*, may indeed have largely transcended product line differences.

The trial judge held that ordinary consumers would be unlikely to make any mental link between the marks and the respective wares and services of the parties. This finding was critical, because “a mark is not protected *per se* as an isolated object but rather as an indicator of *source* to distinguish one person’s goods (or services) from another person’s.”

The depreciation or anti-dilution remedy is sometimes referred to as a “super weapon” which, in the interest of fair competition, needs to be kept in check.

PREMIER BRANDS UK LTD v TYPHOON EUROPE LTD

[2000] FSR 767 [UK]

Finally, it is right to mention that, as [counsel] also submitted, s 10(3) is not intended to have the sweeping effect of preventing the use of any sign which is the same, or similar to, a registered trademark with a reputation; nor is s 10(3) intended to enable the proprietor of a well known registered mark to be able to object as a matter of course to the use of a sign which may remind people of his mark. In at least three decisions in the Trademark Registry, it has been held that what s 10(3) is intended to prevent is the use of a sign which exploits the distinctive character or repute of an established trademark in either or both of the ways contemplated in paragraphs (a) and (b) of that subsection.¹³⁸

The Advocate General's opinion in *General Motors*¹³⁹ expressed a similar word of caution:

"It is to be noted in particular that Article 5(2) [of the EU directive] does not refer to a mere risk or likelihood of its conditions being fulfilled. The wording is more positive: "takes unfair advantage of, or is detrimental to". Moreover, the taking of unfair advantage or the suffering of detriment must be properly substantiated, that is to say, properly established to the satisfaction of the national court: the national court must be satisfied by evidence of actual detriment, or of unfair advantage."

14. *Confusion is not required for dilution:* Although confusion is not required, there must be a link in the mind of the public between the registered mark and the infringing mark

PREMIER BRANDS UK LTD v TYPHOON EUROPE LTD

[2000] FSR 767 [UK]

The absence of any reference in s 10(3) to confusion, particularly in light of the express reference thereto in s 10(2), appears to me to emphasize that the proprietor of a trademark can claim that the use of a sign infringes his rights notwithstanding the absence of any confusion between the sign and his mark.

138 *Oasis Stores Ltd's TM Application* [1998] RPC 631 [UK].

139 ECJ, 14 September 1999, *General Motors / Yplon*, C-375/97, ECR 1999, I-5421.

ADIDAS-SALOMON AG v FITNESSWORLD TRADING LTD

ECJ, 23 October 2003, C-408/01, ECR 2003, I-12537

Article 5(2) establishes, for the benefit of trademarks with a reputation, a form of protection whose implementation does not require the existence of such a likelihood [of confusion]. Article 5(2) applies to situations in which the specific condition of the protection consists of a use of the sign in question without due cause which takes unfair advantage of, or is detrimental to, the distinctive character or the repute of the trademark.

The protection conferred is not conditional on a finding of a degree of similarity between the mark with a reputation and the sign such that there exists a likelihood of confusion between them on the part of the relevant section of the public.

It is sufficient for the degree of similarity between the mark with a reputation and the sign to have the effect that the relevant section of the public establishes a link between the sign and the mark.

15. *The meaning of unfair advantage:*

L'ORÉAL SA v BELLURE NV

ECJ, 18 June 2009, C-487/07, ECR 2009, I-5185

Those types of injury are, first, detriment to the distinctive character of the mark, secondly, detriment to the repute of that mark and, thirdly, unfair advantage taken of the distinctive character or the repute of that mark.

As regards the concept of "taking unfair advantage of the distinctive character or the repute of the trade mark", also referred to as "parasitism" or "free-riding", that concept relates not to the detriment caused to the mark but to the advantage taken by the third party as a result of the use of the identical or similar sign. It covers, in particular, cases where, by reason of a transfer of the image of the mark or of the characteristics which it projects to the goods identified by the identical or similar sign, there is clear exploitation on the coat-tails of the mark with a reputation.

This approach has not found favor with English courts in the follow-up judgment in *L'Oreal SA v Bellure NV* [2010] EWCA Civ 535 when it said this:

So far as I can see this is saying if there is clear exploitation on the coat-tails that is *ipso facto* not only an advantage but an unfair one at that. In short, the provision should be read as though the word “unfair” was simply not there. No line between permissible free riding and impermissible free riding is to be drawn. All free-riding is unfair. It is a conclusion high in moral content (the thought is clearly that copyists, even of lawful products should be condemned) rather than on economic content.

PREMIER BRANDS UK LTD v TYPHOON EUROPE LTD

[2000] FSR 767 [UK]

In *Dimple* [1985] GRUR 550, the German Federal Supreme Court said that:

“The courts have repeatedly held that it constitutes an act of unfair competition to associate the quality of one’s goods or services with that of prestigious competitive products for the purpose of exploiting the good reputation of a competitor’s goods or services in order to enhance one’s promotional efforts”.

Those observations are appropriate to a case where the sign is said to “take unfair advantage of” a mark with established substantial goodwill. Observations of the German Federal Supreme Court in another case, *Quick* [1959] GRUR 182, are relevant to the other type of case, namely where use of the sign “is detrimental to” a well-established mark:

“The owner of a distinctive mark has a legitimate interest in continuing to maintain the position of exclusivity he acquired through large expenditures of time and money and that everything which could impair the originality and distinctive character of his distinctive mark, as well as the advertising effectiveness derived from its uniqueness, is to be avoided. Its basic purpose is not to prevent any form of confusion but to protect an acquired asset against impairment.”

This sort of detriment has been generically described as “dilution”, and has also been said to occur normally in one of two ways, namely by “blurring” or by “tarnishing”.

16. Blurring of a trademark:***L'ORÉAL SA v BELLURE NV***

ECJ, 18 June 2009, C-487/07, ECR 2009, I-5185

As regards detriment to the distinctive character of the mark, also referred to as “dilution”, “whittling away” or “blurring”, such detriment is caused when that mark’s ability to identify the goods or services for which it is registered is weakened, since use of an identical or similar sign by a third party leads to dispersion of the identity and hold upon the public mind of the earlier mark. That is particularly the case when the mark, which at one time aroused immediate association with the goods or services for which it is registered, is no longer capable of doing so.

PREMIER BRANDS UK LTD v TYPHOON EUROPE LTD

[2000] FSR 767 [UK]

Blurring occurs where the distinctiveness of a mark is eroded. A pithy explanation of blurring may be found in the observations of Sir Thomas Bingham MR in *Taittinger SA v Allbev Ltd* [1993] FSR 641 where he said this [in the context of passing off]:

“The first plaintiff’s reputation and goodwill in the description Champagne derive not only from the quality of their wine and its glamorous associations, but also from the very singularity and exclusiveness of the description, the absence of qualifying epithets and imitative descriptions. Any product which is not Champagne but is allowed to describe itself as such must inevitably, in my view, erode the singularity and exclusiveness of the description Champagne and so cause the first plaintiffs damage of an insidious but serious kind”.

17. Tarnishing of a trademark:***L'ORÉAL SA v BELLURE NV***

ECJ, 18 June 2009, C-487/07, ECR 2009, I-5185

As regards detriment to the repute of the mark, also referred to as “tarnishment” or “degradation”, such detriment is caused when the goods or services for which the identical or similar sign is used by the third party may be perceived by the public in such a way that the trade mark’s power of attraction is reduced. The likelihood of such detriment may arise in particular from the fact that the goods or services offered by the third party possess a characteristic or a quality which is liable to have a negative impact on the image of the mark.

LAUGH IT OFF PROMOTIONS CC v SAB INTERNATIONAL (FINANCE) BV

[2004] ZASCA 76 [South Africa]

The instant case is, however, not concerned with blurring but rather with tarnishment. *FW Mostert* [Famous and Well-Known Marks (2 ed) 1-103] quotes another German case to illustrate: the owner of the well-known perfume “4711” was able to interdict a sewer company from using the number on a malodorous tank truck even though the number only formed part of its telephone number. Courts in different jurisdictions have come to similar conclusions on similar facts in this regard. For instance, the use of the American Express charge card and the slogan “Don’t leave home without it” in relation to condoms was not acceptable to a US court [*American Express Co v Vibra Approved Laboratories Corp* 10 USPQ 2d 2006 (SDNY 1989)]. In Germany, the Federal Supreme Court found that the use of the confectionary trademark Mars and its slogan that it will liven you up in relation to a gag item consisting of a condom, tarnished Mars [Case I ZR 79/92, 1995 [26] IIC 282]. And in England an attempt to register Visa as a trademark, also in relation to condoms, was dismissed on the same ground [*A Sheimer (M) SDN BHD’s Trademark Application* [2000] RPC 13 (p 484)].

18. Parody:

LAUGH IT OFF PROMOTIONS CC v SAB INTERNATIONAL (FINANCE) BV

[2004] ZASCA 76 [South Africa]

As in the case of copyright infringement, parody cannot per se be a defense against trademark infringement in terms of s 34(1)(c). It is nevertheless a factor like the other factors mentioned above that has to be considered in determining whether a defendant’s use of a mark contrary to the provisions of s 34(1)(c) is constitutionally protected.

A good example of fair parody is to be found in the judgment of the Paris Tribunal de Grande Instance in *Greenpeace France v Esso* [26 February 2003 General index registration number: 2002/16307, 2002/17820]. Greenpeace used, instead of the trademark ESSO, the mark E\$O in a context in which it criticized Esso’s ecological record. The court found that to be permissible because Greenpeace should be able to, in its writings or on its internet site, denounce, as it considers appropriate to the goal pursued, the environmental impacts and human health risks caused by certain of Esso’s industrial activities. The court pointed out that this freedom is not absolute and it can be subject to the restrictions necessary for the protection of the rights of others.

Although the mark E\$\$O refers to Esso's trademark, Greenpeace did not aim to promote its products or service commercially but used E\$\$O for polemical purposes. This underscores the view that parody in France is not a per se trademark defense but that the exception of parody appears to be allowed in relation to trademarks provided, inter alia, that the parody was not made for commercial purposes and does not overstep the limits of parody.

On the other hand, in *Mutual of Omaha Insurance Co v Novak* [836 F 2d 397 402], the defendant, who was protesting nuclear proliferation, used the trademark of an insurance company to make his point on T-shirts and coffee mugs. This use was found not to be parody because the defendant was not commenting on the plaintiff's trademark or business.

In *Anheuser-Busch Inc v Balducci Publications* [28 F3d 769 (1994)] the defendant placed a fake advertisement, which it thought humorous, in which the plaintiff's beer Michelob was represented as an oily product. The intended message concerned an oil spill which had no connection with Michelob and water pollution in general. No other justification was proffered for the damaging implication that Michelob contained oil. In balancing the trademark owner's rights against that protected under the First Amendment, the court found that the First Amendment defense had to yield to Michelob's rights.

19. *The test for detriment:*

PEBBLE BEACH COMPANY v LOMBARD BRANDS

[2002] ScotCS 265 [Scotland]

I must also be satisfied that there is a *prima facie* case that the defenders' use of the sign would take unfair advantage of the distinctive character or repute of the pursuers' trademark. Not only must this advantage be unfair, but it must be of a sufficiently significant degree to warrant restraining what is, *ex hypothesi*, a non-confusing use. It is worthy of note that there is a general reluctance to apply these provisions too widely.

In *Pfizer Limited v Eurofood Link (UK) Ltd* [2000] ETMR 896 Mr Simon Thorley QC observed that,

“the concept of ‘unfair advantage’ requires an inquiry into the benefit to be gained by the defendant from the use of the mark complained of and the concept of ‘detriment’ requires an inquiry

into the damage to the goodwill accruing to the business in the goods sold under the trademark. The advantage or detriment must be of a sufficiently significant degree to warrant restraining what is, *ex hypothesi*, a non-confusing use.”

Finally any advantage to the defenders must not only be unfair but more than *de minimis* – see *Barclays Bank Plc v RBS Advanta* [1996] RPC 307: “The use must either give some advantage to the defendant or inflict some harm on the character or repute of the registered mark which is above the level of *de minimis*.”

20. *The likelihood of detriment:* The degree of proof of detriment depends much on the terms of local laws. In the EU and, consequently the UK, the requirement is detriment or unfair advantage while in South Africa the Act requires a likelihood, and not actual detriment or unfair advantage. In the US, the statute was amended after the *Victoria’s Secrets* judgment¹⁴⁰ and proof of actual harm is no longer required. Be that as it may, the South African Constitutional Court interpreted the Act in the way set out below.

LAUGH IT OFF PROMOTIONS CC v SAB INTERNATIONAL (FINANCE) BV

[2005] ZACC 7 [South Africa]

I hold that in a claim under s 34(1)(c), a party that seeks to oust an expressive conduct protected under the Constitution must, on the facts, establish a likelihood of substantial economic detriment to the claimant’s mark. There is indeed much to be said for the contention that, in a claim based on tarnishment of a trademark, the probability of material detriment to the mark envisaged in the section must be restricted to economic and trade harm. In essence the protection is against detriment to the repute of the mark; and not against the dignity but the selling magnetism of the mark. In an open democracy valuable expressive acts in public ought not to be lightly trampled upon by marginal detriment or harm unrelated to the commercial value that vests in the mark itself.

The standard of proof was expressed differently in these terms by the ECJ in the *TDK* judgment:

140 *Moseley dba Victor’s Little Secret v V Secret Catalogue Inc* 123 S Ct 1115; 65 USPQ 2d 1801.

AKTIESELKABET v OHIN - TDK KK

ECJ, 12 December 2008, C-197/07 P, ECR 2008, I-193

With regard to the appellant's argument concerning the standard of proof required of the existence of unfair advantage taken of the repute of the earlier mark, it must be noted that it is not necessary to demonstrate actual and present injury to an earlier mark; it is sufficient that evidence be produced enabling it to be concluded *prima facie* that there is a risk, which is not hypothetical, of unfair advantage or detriment in the future.

TRADEMARKS: DEFENSES

CHAPTER VI

1. *Introduction:* Some defenses to trademark infringement have been alluded to during the discussion thus far.

The main defense to a claim based on trademark infringement is usually a denial of infringement. Since the onus rests on the trademark owner to establish infringement, the issue then is whether the claimant is able to establish the requirements for infringement.

2. *Invalidity of the trademark registration:* As far as special defenses are concerned, the most significant one relates to the invalidity of the trademark registration. A trademark registered contrary to one of the prohibitions mentioned earlier is invalid. These include:

- Signs which do not satisfy the requirements of a trademark, i.e., signs incapable of being represented graphically or not capable of distinguishing goods or services of one undertaking from those of other undertakings,
- Trademarks that are devoid of any distinctive character,
- Trademarks that consist exclusively of signs or indications which may serve, in trade, to designate the kind, quality, quantity, intended purpose, value, geographical origin, the time of production of goods or of rendering of services, or other characteristics of goods or services,
- Trademarks that consist exclusively of signs or indications which have become customary in the current language or in the *bona fide* and established practices of the trade.

If it is established that the trademark was registered contrary to a prohibition it should be deleted from the register. Some legal systems permit a defendant to raise invalidity as a defense. Others require a counter-application for rectification of the register on the assumption that as long as the trademark appears on the register it is enforceable.

3. *Statutory defenses:* Trademark acts may also contain special defenses which do not relate to the validity of the trademark registration. The UK Act, for instance, states that a registered trademark is not infringed by:

- the use by a person of his own name or address,¹⁴¹
- the use of indications concerning the kind, quality, quantity, intended purpose, value, geographical origin, the time of production of goods or of rendering of services, or other characteristics of goods or services, or

141 *Hotel Cipriani Srl v Cipriani (Grosvenor Street) Ltd* [2010] EWCA Civ 110 (24 February 2010).

- the use of the trademark where it is necessary to indicate the intended purpose of a product or service (in particular, as accessories or spare parts), provided the use is in accordance with honest practices in industrial or commercial matters.

It furthermore provides that a registered trademark is not infringed by use in the course of trade in a particular locality of an earlier right which applies only in that locality. An earlier right is an unregistered trademark or other sign continuously used in relation to goods or services by a person or a predecessor in title of his from a date prior to whichever is the earlier of:

- the use of the first-mentioned trademark in relation to those goods or services by the proprietor or a predecessor in title of his, or
- the registration of the first-mentioned trademark in respect of those goods or services in the name of the proprietor or a predecessor in title of his; and an earlier right shall be regarded as applying in a locality if, or to the extent that, its use in that locality is protected by virtue of any rule of law (in particular, the law of passing off).

4. *Fair use*: US law makes express provision for a fair use defense where:¹⁴²

“the use of the name, term, or device charged to be an infringement is a use, otherwise than as a mark ... of a term or device which is descriptive of and used fairly and in good faith only to describe the goods or services of such party, or their geographic origin.”

The object of the fair use defense is to prevent a trademark owner from monopolizing or appropriating a descriptive word or phrase since everyone is free to use a term in its primary, descriptive sense so long as such use does not lead to customer confusion as to the source of the goods or services.¹⁴³ In the earlier discussion reference was made to trademark use as a requirement of trademark infringement. This fair use defense does not differ in principle from that requirement.

“The purpose of the statutory fair use defense is to allow non-owners of the trademark to accurately describe their goods. Therefore, the defense is only available when the mark at issue is descriptive, and then, only where the descriptive term is used descriptively. Because the use is ‘otherwise than as a mark,’ the ‘fair use’ of someone else’s descriptive trademark should not be likely to cause confusion.”¹⁴⁴

142 US Lanham Act s 33(4)(b).

143 *Zatarains Inc v Oak Grove Smokehouse Inc* 698 F.2d 786 (5th Cir. 1983) [USA].

144 Baila H Celedonia “Trademark fair use”: www.cll.com/practice/intellectualproperty/articles.cfm.

NEW KIDS ON THE BLOCK v NEWS AMERICA PUBLISHING INC

971 F.2d 302 [USA]

Where the defendant uses a trademark to describe the plaintiff's product, rather than its own, we hold that a commercial user is entitled to a nominative fair use defense provided he meets the following three requirements: First, the product or service in question must be one not readily identifiable without use of the trademark; second, only so much of the mark or marks may be used as is reasonably necessary to identify the product or service; and third, the use must do nothing that would, in conjunction with the mark, suggest sponsorship or endorsement by the trademark holder.

CENTURY 21 REAL ESTATE CORPORATION v LENDINGTREE INC

425 F.3d 211 [USA]

Nominative fair use is said to occur when the alleged infringer uses the [trademark holder's] product, *even if the alleged infringer's ultimate goal is to describe his own product*. Nominative fair use also occurs if the only practical way to refer to something is to use the trademarked term. By contrast, classic fair use occurs where the defendant uses the plaintiff's mark to describe the defendant's own product.

The use of the term 'Volkswagen' by a car mechanic in an advertisement describing the types of cars he repairs has been held to constitute a nominative fair use. Clearly, the mechanic is referring to another's product, but does so in order to describe what he does. On the other hand, the use of the term 'micro-colors', a registered trademark of one make-up company, referring to the pigments of the product of a different and competing make-up company that it used in its own product, was classified as a classic fair use. There, the reference to the mark of another was made in describing its own product and its attributes.

5. *Comparative advertising*: Some laws permit the use of a trademark for purpose of comparative advertising (i.e. advertising which explicitly or by implication identifies a competitor or goods or services offered by a competitor); others do not. But those that permit it place limitations on the use. Comparative advertising is in truth an aspect of unfair competition.

BENCHMARK BUILDING v MITRE 10 (NEW ZEALAND) LTD

[2003] NZCA 213 [New Zealand]

A registered trademark is not infringed by the use of the registered trademark for the purposes of comparative advertising, but any such use otherwise than in accordance with honest practices in industrial or commercial matters must be treated as infringing the registered trademark if the use, without due cause, takes unfair advantage of, or is detrimental to, the distinctive character or the repute of the trademark.

6. *The EU Directive on comparative advertising*: Typically such provisions are similar to the EU's Comparative Advertising Directive,¹⁴⁵ which permits comparative advertising if, as far as the comparison is concerned, the following conditions are met:

- it is not misleading;
- it compares goods or services meeting the same needs or intended for the same purpose;
- it objectively compares one or more material, relevant, verifiable and representative features of those goods and services, which may include price;
- it does not create confusion in the market place between the advertiser and a competitor or between the advertiser's trademarks, trade names, other distinguishing marks, goods or services and those of a competitor;
- it does not discredit or denigrate the trademarks, trade names, other distinguishing marks, goods, services, activities, or circumstances of a competitor;
- for products with designation of origin, it relates in each case to products with the same designation;
- it does not take unfair advantage of the reputation of a trademark, trade name or other distinguishing marks of a competitor or of the designation of origin of competing products;
- it does not present goods or services as imitations or replicas of goods or services bearing a protected trademark or trade name.

145 Directive 84/450 concerning misleading and comparative advertising, as amended by Directives 97/55 and 2005/29, available at: <http://eur-lex.europa.eu/LexUriServ/LexUriServ.do?uri=CONSLEG:1984L0450:20050612:EN:PDF>

7. *Judgments on the interpretation of the EU Directive:*

SIEMENS AG v VIPA

ECJ, 23 February 2006, C-59/05, ECR 2006, I-2147:

It follows that the benefit of comparative advertising to consumers must necessarily be taken into account in determining whether an advertiser is taking unfair advantage of the reputation of a trademark, trade name or other distinguishing marks of a competitor.

On the other hand, the benefit an advertiser derives from comparative advertising, which, by reason of its very nature, is self-evident in all cases, cannot alone be determinative of whether the conduct of such an advertiser is lawful.

L'ORÉAL SA v BELLURE NV

ECJ, 18 June 2009, C-487/07, ECR 2009, I-5185

[The] Directive must be interpreted as meaning that an advertiser who states explicitly or implicitly in comparative advertising that the product marketed by him is an imitation of a product bearing a well-known trade mark presents 'goods or services as imitations or replicas' within the meaning of Article 3a(1)(h).

The particular object of the condition laid down in Article 3a(1)(h) is to prohibit an advertiser from stating in comparative advertising that the product or service marketed by him constitutes an imitation or replica of the product or the service covered by the trade mark. In that regard, it is not only advertisements which explicitly evoke the idea of imitation or reproduction which are prohibited, but also those which, having regard to their overall presentation and economic context, are capable of implicitly communicating such an idea to the public at whom they are directed.

It is irrelevant in that regard whether the advertisement indicates that it relates to an imitation of the product bearing a protected mark as a whole or merely the imitation of an essential characteristic of that product.

Since, under Directive 84/450, comparative advertising which presents the advertiser's products as an imitation of a product bearing a trade mark is inconsistent with fair competition and thus unlawful, any advantage gained by the advertiser through such advertising will have been achieved as the result of unfair competition and must, accordingly,

be regarded as taking unfair advantage of the reputation of that mark within the meaning of Article 3(1)(g) of that directive.

What this means in plain language is that it is not permitted to advertise as product as having the same qualities as that of the trademarked product, even if the statement is true. The national court was not impressed with the ruling as appears from the following extract.

L'OREAL SA v BELLURE NV

[2010] EWCA Civ 535

The problem, stated at its most general, is simple. Does trade mark law prevent the defendants from telling the truth? Even though their perfumes are lawful and do smell like the corresponding famous brands, does trade mark law nonetheless muzzle the defendants so that they cannot say so?

I have come to the conclusion that the ECJ's ruling is that the defendants are indeed muzzled.

My own strong predilection, free from the opinion of the ECJ, would be to hold that trade mark law did not prevent traders from making honest statements about their products where those products are themselves lawful.

8. Comparative advertising and dilution: Indian law, for one, uses dilution principles in order to determine whether comparative advertising is legitimate. It provides that a registered trademark is infringed by any advertising of that trademark if such advertising takes unfair advantage of and is contrary to honest practices in industrial or commercial matters; is detrimental to its distinctive character; or affects the reputation of the trademark.

9. Exhaustion of rights and parallel importation: Exhaustion of its rights by the trademark owner is also a defense to an infringement action. The issue is discussed in a later chapter.

COPYRIGHT: INTRODUCTION

CHAPTER VII

- A. THE NATURE OF COPYRIGHT (1-3)
- B. THE BERNE CONVENTION (4-8)
- C. THE WIPO COPYRIGHT TREATY (WCT) (1996) (9-11)
- D. TRIPS (12-14)
- E. THE UNIVERSAL COPYRIGHT CONVENTION (1952) (15)
- F. RELATED RIGHTS (16-20)
- G. STATUTORY INSTRUMENTS (21-27)
- H. THE EXPRESSION *versus* IDEA DICHOTOMY (28-30)
- I. MORAL RIGHTS (31-35)

A. THE NATURE OF COPYRIGHT

1. *Introduction:* Copyright, in general terms, is the intellectual property right of a copyright owner to prevent unauthorized productions of a work which is entitled to copyright. Copyright protects the author in his intellectual and personal relationship to his work and the use of the work; and it serves to secure reasonable remuneration for the use of the work.¹⁴⁶
2. *Copyright is a right to property:*

USE BY CHURCHES AND SCHOOLS

Federal Constitutional Court (BVerfG), July 7, 1971 [Germany]

Article 46 of the Copyright Act places a limitation on copyright as defined in that Act. This is out of line with the guarantee of property.

There is no defined, absolute notion of property; the conception and function of property can and must adapt to social and economic relationships. The Constitution has therefore transferred to the legislature the task of determining the content and limitations of property. This also applies to the commercial rights of authors, which, like rights in tangible property, must be embodied in legislation. However, the Constitution does not leave the legislature free to proceed in any way it will. In establishing the powers and obligations that constitute the right, the legislature must safeguard the essential content of the guarantee of property, as well as maintaining conformity with all other constitutional standards. For the protection of copyright to be constitutional, it must incorporate the content ensuing from these standards.

One of the essential features of copyright as property in the sense of the Constitution is that the commercial product of the author's creative work belongs in principle to the author under the standards of civil-law, and that the author has the freedom to do with his/her creation as he/she sees fit. This forms the constitutionally protected core of copyright.

146 Using the German statute's description.

*INTERSTATE PARCEL EXPRESS CO PTY LTD v TIME-LIFE INTERNATIONAL
(NEDERLANDS) BV*

[1977] HCA 52 [Australia]

By the grant of a patent in traditional form, a patentee is granted exclusive power to 'make, use, exercise and vend' the invention. The sale of a patented article, by the patentee, would be quite futile, from the point of view of the buyer, if the buyer was not entitled either to use or to re-sell the article which he had bought. It therefore seems necessary, in order to give business efficacy to such a sale, to imply a term that the patentee consents to the use of the patented article by the buyer and those claiming under him. The law accordingly does ordinarily imply the consent of the patentee 'to an undisturbed and unrestricted' use of the patented article. To make such an implication, for the purpose only of avoiding the restrictions upon the use of the article that would otherwise be imposed by the patent, seems to be perfectly consistent with the ordinary rules governing the implication of terms in contracts.

However no similar necessity exists to imply a term of this kind upon the sale of a book the subject of copyright. The owner of copyright has not the exclusive right to use or sell the work in which copyright subsists. The buyer of a book in which copyright subsists does not need the consent of the owner of the copyright to read, or speaking generally to re-sell, the book. The necessity to imply a term in the contract which exists when a patented article is sold does not arise on the sale of a book the subject of copyright. It was not, and could not be, suggested that the sale of a copy of a book is a license to do the acts comprised in the copyright.¹⁴⁷

Copyright is also capable of transfer or assignment, sometimes subject to formalities.¹⁴⁸ (Moral rights as a general rule cannot be assigned.)

3. *Is copyright a negative right?* It is often said that copyright is a negative right.

ASHDOWN v TELEGRAPH GROUP LTD

[2001] EWCA Civ 1142 [UK]

Despite ss 2(1) and 16(2) copyright is essentially not a positive but a negative right. No provision of the Copyright Act confers in terms,

147 Quoted in *Creative Technology Ltd v Aztech Systems Pte Ltd v Aztech Systems Pte Ltd* [1997] FSR 491 (CA) [Singapore]. The buyer's freedom to resell a copy of certain works is expressly regulated in that the right of distribution is granted only for the first sale by, or with the authorization of, the right owner, not in relation to subsequent sales of the copies sold.

148 *Crosstown Music Company 1, LLC v Rive Droite Music Ltd & Ors* [2010] EWCA Civ 1222.

upon the owner of copyright in a literary work, the right to publish it. The Act gives the owner of the copyright the right to prevent others from doing that which the Act recognizes the owner alone has a right to do. It prevents all, save the owner of the copyright, from expressing information in the form of the literary work protected by the copyright.

The correctness of the statement, even in present-day English law, is debatable.

The right to prevent someone from doing what is the author's exclusive right is the reverse side of the positive right. There is also a difference between the right to reproduce and the right to publish (although they may overlap) – the former is the subject of copyright; the latter not.

This view is reflected in the common-law world in, for instance, the Canadian and South African laws. The former defines copyright, in relation to a work, as the sole right to produce or reproduce the work or any substantial part thereof in any material form whatever, to perform the work or any substantial part thereof in public or, if the work is unpublished, to publish the work or any substantial part thereof. The South African Act, similarly, provides that "copyright in a literary or musical work vests the exclusive right to do or to authorize the doing of any of the [listed] acts in the Republic [such as] reproducing the work in any manner or form."

The civil-law is no different. The Copyright Act of the Netherlands, for one, states that copyright is the exclusive right of the author of a literary, scientific or artistic work to communicate that work to the public and to reproduce it (s 1).

Alliance Entertainment Singapore Pte Ltd v Sim Kay Teck

[2007] SGHC 43

"Copyright" is the term used to refer to certain intellectual property rights in a work. The bundle of rights that comprises copyright exists as a chose in action. In common with other species of property, it can be transmitted or dealt with by the copyright owner in a variety of ways. This can range from a complete assignment of the legal and/or beneficial title to an assignee, to a variety of transactions where something short of title is conveyed. In some instances, it may simply be the grant of a license or permission to enjoy the copyright in particular geographic areas, either alongside or to the exclusion of the owner of copyright.

B. THE BERNE CONVENTION

4. *The Berne Convention*: The Berne Convention dates back to September 9, 1886. It has been the subject of a number of revisions and the Paris revision of July 24, 1971 is incorporated by reference into the TRIPS Agreement and the WIPO Copyright Treaty.
5. *Basic principles*: The Berne Convention rests on three basic principles:¹⁴⁹
 - *National treatment*. Works originating in one of the contracting States (that is, works the author of which is a national of such a State or works which were first published in such a State) must be given the same protection in each of the other contracting States as the latter grants to the works of its own nationals (Art. 2(6), 3 and 5(3).
 - *Automatic protection*. Copyright protection may not be conditional upon compliance with any formality. This means that copyright protection is not dependent on registration or the like. (Art. 5.)
 - *Independence of protection*. Copyright protection is independent of the existence of protection in the country of origin of the work. (Art. 5(2).) If, however, a contracting state provides for a longer term than the minimum prescribed by the Convention and the work ceases to be protected in the country of origin, protection may be denied as soon as protection in the country of origin ceases. (Art 6(1).)

FRANCOIS LUCAZEAU v SOCIETE DES AUTEURS (SACEM)

ECJ, 13 July 1989, joined cases 110/88, 241/88 and 242/88, ECR 1989, 2811:

Under the international copyright conventions, the owners of copyright recognized under the legislation of a contracting State are entitled, in the territory of every other contracting State, to the same protection against the infringement of copyright, and the same remedies for such infringement, as the nationals of the latter State.

6. *Definition of works entitled to copyright*: The Berne Convention uses an expansive and non-limiting definition of literary and artistic works to describe the works that are entitled to copyright protection (Art. 2(1)). They include every production in the literary, scientific and artistic domain, whatever may be the mode or form of expression, such as:

149 Taken from the WIPO website where the Treaties that follow appear: <http://www.wipo.int/treaties/en/>.

- books, pamphlets and other writings;
- lectures, addresses, sermons and other works of the same nature;
- dramatic or dramatico-musical works;
- choreographic works and entertainments in dumb show;
- musical compositions with or without words;
- cinematographic works to which are assimilated works expressed by a process analogous to cinematography;
- works of drawing, painting, architecture, sculpture, engraving and lithography;
- photographic works to which are assimilated works expressed by a process analogous to photography;
- works of applied art;
- illustrations, maps, plans, sketches; and
- three-dimensional works relative to geography, topography, architecture or science.”

7. Exclusive rights: Although copyright is primarily the right to prevent unauthorized productions of a work that is entitled to copyright, there is more to it. For instance, in later years the distribution right became recognized: this enables the copyright owner to control the distribution of the work in the case of, particularly, audio-visual works (films).

Subject to certain permitted reservations, limitations or exceptions, the following are among the rights that must be recognized as exclusive rights of authorization, namely the rights to:

- translate,
- make adaptations and arrangements of the work,
- perform in public dramatic, dramatico-musical and musical works,
- recite in public literary works,
- communicate to the public the performance of such works,
- broadcast,
- make reproductions in any manner or form,
- use the work as a basis for an audiovisual work, and
- reproduce, distribute, perform in public or communicate to the public that audiovisual work.

8. Exceptions: The Berne Convention allows for exceptions to copyright protection. These have been amplified by the TRIPS Agreement. This subject is dealt with in greater detail in Chapter 9. Some special provisions are noted here.

The Berne Convention does not extend copyright protection to news of the day or to miscellaneous facts having the character of mere items of press information (Art. 2(8)).

The Berne Convention also permits countries to provide for a limited number of exceptions to the general obligation to provide copyright protection for the listed works. For instance, it is possible to exclude, wholly or in part, political speeches and speeches delivered in the course of legal proceedings from copyright protection.

Likewise, national legislation may determine the conditions under which lectures, addresses and other works of the same nature, which are delivered in public, may be reproduced by the press, broadcast, communicated to the public by wire or made the subject of public communication when such use is justified by the informatory purpose. (Art. 2bis.)

German law (for example) provides for this exception:

Following publication, the reproduction, distribution and public disclosure is permitted of parts of a work, of literary works or musical works of small size, of individual visual art works or individual photographic works, as part of a collection combining works of a large number of authors, and which by its nature is intended only for teaching purposes in schools, for non-commercial educational and training establishments or vocational training institutions, or for church use. A clear indication of the intended use of the collection is to be given in the copies made or on public disclosure.

The Appendix to the Berne Convention (introduced in the Paris revision) contains additional discretionary exclusions. Developing countries are, for instance, entitled, in relation to works published in printed or analogous forms of reproduction, to substitute for the exclusive right of translation a system of non-exclusive and non-transferable licenses, granted by a competent authority subject to conditions and article III permits a licensing system for the publication of certain published works for educational purposes.

C. THE WIPO COPYRIGHT TREATY (WCT) (1996)¹⁵⁰

9. *The subject matter of the Treaty:* The Treaty in a sense duplicates the provisions of the TRIPS Agreement by incorporating by reference all the substantive provisions of the Berne Convention and by introducing two new subject matters, which are to be protected by copyright, namely:

- computer programs, irrespective of the mode or form of their expression, and

150 WIPO Publication No.489 Ch 5 *International Treaties and Conventions on Intellectual Property* <http://www.wipo.int/export/sites/www/about-ip/en/iprm/pdf/ch5.pdf>.

- compilations of data or other material (databases), in any form, which by reason of the selection or arrangement of their contents constitute intellectual creations.

In addition it set out to clarify existing norms and, where necessary, create new norms to respond to the problems raised by digital technology, and particularly by the Internet. This is referred to as the digital agenda.

The provisions of the WCT relating to the agenda cover the following issues:

- the rights applicable to the storage and transmission of works in digital systems,
- the limitations on and exceptions to rights in a digital environment,
- technological measures of protection, and
- rights management information.

10. *Distribution, rental and communications rights:* The Treaty also deals in some detail with certain rights of specified authors (not only of authors of computer programs or databases) and accords them three, namely a distribution, rental and communications right.

- The distribution and rental rights apply to originals and copies of computer programs, cinematographic works and works embodied in phonograms. The right of distribution is the right to authorize the making available to the public of the original and copies of a work through sale or other transfer of ownership. The right of rental is the right to authorize commercial rental to the public of these works.
- The right of communication to the public, which is the right to authorize any communication to the public, consists of two rights. The first is the right of transmission of a work by electronic means and the second is the right of making a work available to the public in such a way that members of the public may access the work from a place and at a time individually chosen by them. Put in terms of infringement: it amounts to an infringement to transmit a copyright work electronically. But it is also an infringement to place a work on the Internet in such a manner that others can access the work at will.

These are all exclusive rights, and are subject to limitations and exceptions. They are in addition to the right of reproduction in material form, and prohibit downloading of an infringing file from the Internet and subsequently saving it.

11. *The nature and limits of the distribution right:*

CASE NUMBER: 2001(JU)NO.952

Supreme Court, the First Petty Bench (Japan)

Reporter: Minshu Vol.56, No.4, at 808

The right of distribution of works of film was introduced as the implementation of the provision in the Berne Convention (amended in Brussels on June 26, 1948) on the distribution right of cinematograph films. The reasons why distribution rights were acknowledged only in relation to films were because for film production requires substantial investment; there was a need to control the distribution to ensure the effective retrieval of the investment; and because of the then existing system of distribution of films for theatres (which presupposed a repeated rental); and, furthermore, because it was difficult to control the screening of a film contrary to the wishes the copyright holder. It was accordingly necessary to control the distribution as well as the assignment and rental of copies. Because of these reasons the Copyright Law was interpreted to mean that the right to assign or rent cinematograph films for public viewing is not exhausted.

D. TRIPS

12. *The TRIPS Agreement:* The TRIPS Agreement contains a number of provisions relating to copyright and related rights. In particular, Member countries of the WTO are obliged to comply with the major provisions of the Berne Convention.

13. *Extension of copyright:* The nature of copyrightable material is expressly extended to cover computer programs and compilations of data (Art. 10):

- Computer programs, whether in source or object code, must be protected as literary works under the Berne Convention (1971).
- Compilations of data or other material, whether in machine-readable or other form, which by reason of the selection or arrangement of their contents constitute intellectual creations, must be protected as such. This protection, which does not extend to the data or material itself, does not affect any copyright subsisting in the data or material.

14. *Term of protection:* The TRIPS Agreement requires a minimum term of protection (Art. 12):

Whenever the term of protection of a work, other than a photographic

work or a work of applied art, is calculated on a basis other than the life of a natural person, such term shall be no less than 50 years from the end of the calendar year of authorized publication, or, failing such authorized publication within 50 years from the making of the work, 50 years from the end of the calendar year of making.

The Berne Convention has a similar provision but some countries have now adopted a 70-year term while a 99- and a 100- year term are also to be found.

E. THE UNIVERSAL COPYRIGHT CONVENTION (1952) ¹⁵¹

15. *The Universal Copyright Convention (1952)*: This Convention, which is administered by UNESCO, requires of its contracting States to provide for the adequate and effective protection of the rights of authors and other copyright proprietors in literary, scientific and artistic works, including writings, musical, dramatic and cinematographic works, and paintings, engravings and sculpture. The reason for this convention was the fact that the US had refused to become party to the Berne Convention, since it would have required major changes in its copyright law, particularly with regard to moral rights, the requirement for registration of copyright works, and the mandatory copyright notice. This Convention has since lost much of its relevance because the USA has, in 1989, changed its stance and joined the Berne Convention, which is in addition incorporated into the TRIPS Agreement. Furthermore, according to the Universal Convention, the relationship between Member States that have adhered to both the Berne Convention and the Universal Convention are to be regulated by the former.

The provisions of the Universal Convention have not been made applicable by TRIPS and it does not contain any provisions relevant to the present work.

F. RELATED RIGHTS

16. *Related rights*: Rights related to copyright are dealt with by conventions other than the Berne Convention. These are listed but will not be discussed separately because there is hardly any case law available and because they do not create problems with interpretation or application.

17. *Rome Convention for the Protection of Performers, Producers of Phonograms and Broadcasting Organizations (1961)*: The Rome Convention

¹⁵¹ Keiko Momii Partial Amendment of the Copyright Law and the Law concerning Exceptional Provisions of the Copyright Law Required in Consequence of the Implementation of the Universal Copyright Convention: http://www.cric.or.jp/cric_elcuj/cuj00/cuj00_3.html.

secures protection for a period of 20 years in performances of performers, phonograms of producers of phonograms and broadcasts of broadcasting organizations.

- Performers (actors, singers, musicians, dancers and other persons who perform literary or artistic works) are protected against certain acts they have not consented to. They are: the broadcasting and the communication to the public of their live performance; the fixation of their live performance; the reproduction of such a fixation if the original fixation was made without their consent or if the reproduction is made for purposes different from those for which they gave their consent.
- Producers of phonograms enjoy the right to authorize or prohibit the direct or indirect reproduction of their phonograms. Phonograms are defined in the Rome Convention as meaning any exclusively aural fixation of sounds of a performance or of other sounds. When a phonogram published for commercial purposes gives rise to secondary uses (such as broadcasting or communication to the public in any form), a single equitable remuneration must be paid by the user to the performers, or to the producers of phonograms, or to both; contracting states are free, however, not to apply this rule or to limit its application.
- Broadcasting organizations enjoy the right to authorize or prohibit certain acts, namely: the re-broadcasting of their broadcasts; the fixation of their broadcasts; the reproduction of such fixations; the communication to the public of their television broadcasts if such communication is made in places accessible to the public against payment of an entrance fee.

18. *The Convention for the Protection of Producers of Phonograms against Unauthorized Duplication of their Phonograms (1971):* This Convention obliges contracting States to protect a producer of phonograms who is a national of another contracting State against

- the making of duplicates without the consent of the producer,
- the importation of such duplicates, where the making or importation is for the purposes of distribution to the public, and
- the distribution of such duplicates to the public.

“Phonogram” means an exclusively aural fixation (that is, it does not comprise, for example, the sound tracks of films or videocassettes), whatever its form (disc, tape or other). Protection may be provided as a matter of copyright law, *sui generis* (related rights) law, unfair competition law or penal law. Protection must last for at least 20 years from the first fixation

or the first publication of the phonogram. (However, the TRIPS Agreement in Art. 14.5 sets out an obligation to extend the term of protection for the rights of performers and producers of phonograms to fifty years, but not for broadcasting organizations.)

19. *Brussels Convention Relating to the Distribution of Programme-Carrying Signals Transmitted by Satellite (1974)*: The Brussels Convention provides for the obligation of contracting States to take adequate measures to prevent the unauthorized distribution on or from their territory of any program-carrying signal transmitted by satellite.

20. *The WIPO Performances and Phonograms Treaty (WPPT) (1996)*:¹⁵² It deals with the IP rights of two kinds of beneficiaries, namely, performers (actors, singers, musicians, etc.) and producers of phonograms (the persons or legal entities who or which take the initiative and have the responsibility for the fixation of the sound).

The provisions of the WPPT relating to the digital agenda cover the following issues:

- certain definitions,
- rights applicable to storage and transmission of performances and phonograms in digital systems,
- limitations on and exceptions to rights in a digital environment,
- technological measures of protection, and
- rights management information.

The Treaty grants performers four kinds of economic rights in their performances that are fixed in phonograms (though not in audiovisual fixations, such as motion pictures), namely:

- the right of reproduction,
- the right of distribution,
- the right of rental, and
- the right of making available.

152 WIPO Publication No.489 Ch 5 *International Treaties and Conventions on Intellectual Property* <http://www.wipo.int/export/sites/www/about-ip/en/iprm/pdf/ch5.pdf>

G. STATUTORY INSTRUMENTS

21. Local laws: The underlying assumption of this work is that countries have laws in place that comply with their international obligations imposed by the TRIPS Agreement. Because of the similarity of copyright laws, no particular statute will be used as the basis of the discussion.

There are a number of differences between the law relating to copyright in common-law countries and those in civil-law countries. These differences are due to different theoretical approaches to the matter. Where relevant to the present discussion, these will be highlighted. The harmonization of EC copyright law did not address these differences.

Because copyright is based on local statute it is territorial. This means that local courts cannot decide claims for infringement of foreign copyright. It is different in countries that are Members of the Brussels Convention (discussed in Chapter 1) in which event the rule is that local courts have no jurisdiction to determine a claim for the infringement of foreign copyright unless the copyright in dispute is that created by the law of a Member State of the Brussels Convention.¹⁵³

22. Common-law countries. The first Copyright Act was the English Act of Anne of 1709 (or 1710). Many amendments followed until the UK Copyright Act of 1911 (1 & 2 Geo 5 ch 46). In the common-law countries that formed part of the British Empire, copyright laws were primarily based on this Act, which applied directly or by adoption.¹⁵⁴ The Act was replaced by the 1956 UK Copyright Act (4 & 5 Eliz 2 c 74), which formed the basis of further developments in most of these countries.¹⁵⁵

THEBERGE v GALERIE D'ART DU PETIT CHAMPLAIN INC

2002 SCC 34 [Canada]

Copyright in this country [Canada] is a creature of statute and the rights and remedies it provides are exhaustive. This is not to say that Canadian copyright law lives in splendid isolation from the rest of the world. Canada has adhered to the *Berne Convention* and other international treaties on the subject including the *Universal Copyright*

153 *Lucasfilm Ltd v. Ainsworth* [2009] EWCA Civ 1328; *Crosstown Music Company 1, LLC v Rive Droite Music Ltd & Ors* [2010] EWCA Civ 1222; *Cooper v Universal Music Australia Pty Ltd* [2006] FCAFC 187.

154 Section 1(1): "Subject to the provisions of this Act, copyright shall subsist throughout the parts of His Majesty's Dominions to which this Act extends for the term hereinafter mentioned in every original literary dramatic musical and artistic work ..." See also *Butterworth and Co (Publishers) Ltd v Ng Sui Nam* [1987] RPC 485 (CA) [Singapore].

155 *Fauolo v Gray* [1997] WSSC1 (Supreme Court of Western Samoa). "Copyright has its origins in the common law, but is now derived from the provisions of the Copyright Act." *Ashdown v Telegraph Group Ltd* [2001] EWCA Civ 1142. The position in the USA is more complicated due to its federal structure.

Convention. In light of the globalization of the so-called “cultural industries”, it is desirable, within the limits permitted by our own legislation, to harmonize our interpretation of copyright protection with other like-minded jurisdictions. That being said, there are some continuing conceptual differences between the *droit d’auteur* of the continental *civiliste* tradition and the English copyright tradition, and these differences seem to lie at the root of the misunderstanding which gave rise to the present appeal.

BUTTERWORTH AND CO (PUBLISHERS) LTD v NG SUI NAM

[1987] RPC 485 (HC) [Singapore]

Copyright is a creation by statute, and whether or not a work is entitled to copyright protection depends on whether there is any statute which confers copyright in such work. It is not a matter of ‘mercantile’ law or anything of that kind.

Finally, there is the current UK Copyright, Designs and Patents Act of 1988 (as amended) which, in addition to TRIPS, had to comply with copyright directives of the European Union. In form it differs from the classical common-law copyright statutes, although much remained the same.

The US law on copyright is based on the copyright clause in its Constitution “to promote the progress of science and useful arts by securing for limited times to Authors and Inventors the exclusive rights to their respective writings and discoveries.” It is different in some material respects from the common norm, and US precedents must be approached with that in mind.

23. The EU directives: The EU copyright directives were adopted in an attempt to harmonize certain aspects of copyright law in the Union. The main goal of the Council Directive 93/98/EEC of 29 October 1993¹⁵⁶ was to ensure that there was a single duration for copyright and related rights across the European Union. This has since been extended by Directive 2011/77/EU¹⁵⁷ which extends the term of protection of related rights to 70 years.

Directive 96/9/EC of 11 March 1996 deals with the legal protection of databases. A database is “a collection of independent works, data or other materials arranged in a systematic or methodical way and individually accessible by electronic or other means”. It is entitled to copyright protection

156 Directive 93/98/EEC harmonizing the term of protection of copyright and certain related rights has been amended by Directive 2001/29/EC of 22 May 2001 on the harmonization of certain aspects of copyright and related rights in the information society. The consolidated version of Directive 93/98/EEC is available at: <http://eur-lex.europa.eu/LexUriServ/LexUriServ.do?uri=CONSLEG:1993L0098:20010622:EN:PDF>.

157 Directive 2011/77/EU of 27 September 2011 amending Directive 2006/116/EC on the term of protection of copyright and certain related rights, *OJ*, 2011, L265/1.

if by reason of the selection or arrangement of the content it constitutes the author's own intellectual creation.

Databases which aim to be complete, that is, where the entries are selected by objective criteria, are not entitled to copyright protection but to *sui generis* database rights. While copyright protects the creativity of an author, database rights specifically protect the qualitatively and/or quantitatively [a] substantial investment in either the obtaining, verification or presentation of the contents: without a substantial investment (which need not be financial), a database is not entitled to protection. The period of protection for these *sui generis* rights is 15 years while that of the other database rights is 70 years.

24. *Civil-law*: The civil-law countries did not have a basic law similar to UK Copyright Act of 1911 but their laws developed congruently based on principles laid down in the French Literary and Artistic Property Act, Paris (1793), namely that the principle that an exclusive right is conferred on authors because their property flows from their intellectual creation and the Prussian Copyright Act of 1837 which comprised the core concepts of modern copyright, namely that the author rather than the publisher was at the center of the protection, and the protected subject matter consisted of abstract works, rather than specific physical goods.¹⁵⁸

25. *Copyright Acts are comprehensive*: Claims to copyright and the defenses to copyright infringement must be sought in the terms of the applicable legislation.

FRANK & HIRSCH (PTY) LTD v A ROOPANAND BROTHERS (PTY) LTD

1993 (4) SA 279 (A) [South Africa]

The owner of copyright in a certain subject-matter holds a bundle of incorporeal rights created and regulated by statute. The statute determines when and how these rights come into existence, how they may be transferred and when and how they terminate.

BISHOP v STEVENS

1990 CanLII 75 (SCC) [Canada]

Analysis of these arguments must begin by emphasizing that copyright law is purely statutory law, which “simply creates rights and obligations upon the terms and in the circumstances set out in the statute”. First and foremost, then, this case is a matter of statutory interpretation.

CCH CANADIAN LTD v LAW SOCIETY OF UPPER CANADA

2004 SCC 13 [Canada]

In interpreting the scope of the Copyright Act's rights and remedies, courts should apply the modern approach to statutory interpretation whereby 'the words of an Act are to be read in their entire context and in their grammatical and ordinary sense harmoniously with the scheme of the Act, the object of the Act, and the intention of Parliament'.

26. Purposive construction: The definitions are intended to cover developments and purposive construction of the definitions is called for.¹⁵⁹

GOLDEN CHINA TV GAME CENTRE v NINTENDO CO LTD

[1996] 4 All SA 667 (A) [South Africa]

As with many definitions in the Act and its antecedents, very wide terms have been employed. The only reason for this can be an intention to cover future technical innovations by using general words. Legislative inertia ought not to impede human ingenuity and the reasonable protection thereof. Typical is the case of computer programs. The wide wording of the Act made it possible to grant them protection as literary works. It was only in the amending Act that the Legislature dealt with the subject. This general scheme of the Act suggests to me that the definitions in the Act should be interpreted "flexibly, so that it would cover new technologies as they appeared, rather than to interpret those provisions narrowly and so force [the Legislature] periodically to update the act" (*WGN Continental Broadcasting Co v United Video Inc* 693 F.2d 622 at 627).

The Legislature elected, quite prudently, to define terms that have somewhat different ordinary meanings. That means that the definitions have precedence and it would be wrong, at least in the context of this Act, to whittle down wide language to fit one's preconceived ideas of what the terms mean or should mean. The Act is intended not to stifle, but rather to promote human ingenuity and industry.

ROBERTSON v THOMSON CORP

2006 SCC 43 [Canada]

The Copyright Act was designed to keep pace with technological developments to foster intellectual, artistic and cultural creativity. In

159 Cf *Navitaire Inc v Easyjet Airline Co* [2004] EWHC 1725 (Ch) (30 July 2004).

applying the Copyright Act to a realm that includes the Internet and the databases at issue in this case, courts face unique challenges, but in confronting them, the public benefits of this digital universe should be kept prominently in view.

27. *Balancing private and public interests:*

THEBERGE v GALERIE D'ART DU PETIT CHAMPLAIN INC

2002 SCC 34 [Canada]

The Copyright Act is usually presented as a balance between promoting the public interest in the encouragement and dissemination of works of the arts and intellect and obtaining a just reward for the creator (or, more accurately, to prevent someone other than the creator from appropriating whatever benefits may be generated). This is not new.

The proper balance among these and other public policy objectives lies not only in recognizing the creator's rights but in giving due weight to their limited nature. In crassly economic terms it would be as inefficient to over-compensate artists and authors for the right of reproduction as it would be self-defeating to under-compensate them. Once an authorized copy of a work is sold to a member of the public, it is generally for the purchaser, not the author, to determine what happens to it.

Excessive control by holders of copyrights and other forms of intellectual property may unduly limit the ability of the public domain to incorporate and embellish creative innovation in the long-term interests of society as a whole, or create practical obstacles to proper utilization.

ROBERTSON v THOMSON CORP

2006 SCC 43 [Canada]

This Court has repeatedly held that the overarching purposes of the Copyright Act are twofold: promoting the public interest in the encouragement and dissemination of artistic and intellectual works, and justly rewarding the creator of the work. Since these purposes are often in opposition to each other, courts "should strive to maintain an appropriate balance between those two goals".

H THE EXPRESSION versus IDEA DICHOTOMY

28. *Copyright protects expression and not ideas:* The TRIPS Agreement entrenches the principle that copyright protection does not extend to ideas, procedures, methods of operation, or mathematical concepts as such but applies to expressions only (Art. 9.2).

DESIGNER'S GUILD v RUSSELL WILLIAMS TEXTILES LTD

[2000] 1 WLR 2416 (HL) [UK]

It is often said that copyright subsists not in ideas but in the form in which the ideas are expressed. The distinction between expression and ideas finds a place in TRIPS, to which the United Kingdom is a party. Nevertheless, it needs to be handled with care. What does it mean? As Lord Hailsham of St Marylebone said, "it all depends on what you mean by 'ideas'".

Plainly there can be no copyright in an idea which is merely in the head, which has not been expressed in copyrightable form, as a literary, dramatic, musical or artistic work. But the distinction between ideas and expression cannot mean anything so trivial as that. On the other hand, every element in the expression of an artistic work (unless it got there by accident or compulsion) is the expression of an idea on the part of the author. It represents her choice to paint stripes rather than polka dots, flowers rather than tadpoles, use one color and brush technique rather than another, and so on. The expression of these ideas is protected, both as a cumulative whole and also to the extent to which they form a "substantial part" of the work.

Although the term "substantial part" might suggest a quantitative test, or at least the ability to identify some discrete part which, on quantitative or qualitative grounds, can be regarded as substantial, it is clear upon the authorities that neither is the correct test. *Ladbroke (Football) Ltd. v. William Hill (Football) Ltd.* [1964] 1 WLR 273 establishes that substantiality depends upon quality rather than quantity. And there are numerous authorities which show that the "part" which is regarded as substantial can be a feature or combination of features of the work, abstracted from it rather than forming a discrete part. That is what the judge found to have been copied in this case. Or to take another example, the original elements in the plot of a play or novel may be a substantial part, so that copyright may be infringed by a work which does not reproduce a single sentence of the original. If one asks what is being protected in such a case, it is difficult to give any answer except that it is an idea expressed in the copyright work.

If one examines the cases in which the distinction between ideas and the expression of ideas has been given effect, I think it will be found that they support two quite distinct propositions. The first is that a copyright work may express certain ideas which are not protected because they have no connection with the literary, dramatic, musical or artistic nature of the work. It is on this ground that, for example, a literary work which describes a system or invention does not entitle the author to claim protection for his system or invention as such. The same is true of an inventive concept expressed in an artistic work. However striking or original it may be, others are (in the absence of patent protection) free to express it in works of their own. The other proposition is that certain ideas expressed by a copyright work may not be protected because, although they are ideas of a literary, dramatic or artistic nature, they are not original, or so commonplace as not to form a substantial part of the work. It is on this ground that the mere notion of combining stripes and flowers would not have amounted to a substantial part of the plaintiff's work. At that level of abstraction, the idea, though expressed in the design, would not have represented sufficient of the author's skill and labour as to attract copyright protection.

R G ANAND v MIS DELUX FILMS

1978 AIR 1613 [India]

Thus, the position appears to be that an idea, principle, theme, or subject matter or historical or legendary facts being common property cannot be the subject matter of copyright of a particular person. It is always open to any person to choose an idea as a subject matter and develop it in his own manner and give expression to the idea by treating it differently from others. Where two writers write on the same subject similarities are bound to occur because the central idea of both are the same but the similarities or coincidences by themselves cannot lead to an irresistible inference of plagiarism or piracy. Take for instance the great poet and dramatist Shakespeare most of whose plays are based on Greek-Roman and British mythology or legendary stories like Merchant of Venice, Hamlet, Romeo Juliet, Julius Caesar etc. But the treatment of the subject by Shakespeare in each of his dramas is so fresh, so different, so full of poetic exuberance, elegance and erudition and so novel in character as a result of which the end product becomes an original in itself. In fact, the power and passion of his expression, the uniqueness, eloquence and excellence of his style and pathos and bathos of the dramas become peculiar to Shakespeare and leaves precious little of the original theme adopted by him. It will thus be preposterous

to level a charge of plagiarism against the great playwright. In fact, throughout his original thinking, ability and incessant labor Shakespeare has converted an old idea into a new one, so that each of the dramas constitutes a master-piece of English literature. It has been rightly said that “every drama of Shakespeare is an extended metaphor”.

Thus, the fundamental fact which has to be determined where a charge of violation of the copyright is made by the plaintiff against the defendant is to determine whether or not the defendant not only adopted the idea of the copyrighted work but has also adopted the manner, arrangement, situation to situation, scene to scene with minor changes or super additions or embellishment here and there. Indeed, if on a perusal of the copyrighted work the defendant’s work appears to be a transparent rephrasing; or a copy of a substantial and material part of the original, the charge of plagiarism must stand proved. Care however must be taken to see whether the defendant has merely disguised piracy or has actually reproduced the original in a different form, different tone, [and] different tenor so as to infuse a new life into the idea of the copyrighted work adapted by him. In the latter case there is no violation of the copyright.

29. Examples: In the WIPO publication, *Principles of Copyright: Cases and Materials* (2002), Prof David Vaver summed the ideas versus expression dichotomy up under these headings:

- Copyright does not subsist in style.
- Copyright does not subsist merely in news.
- Copyright does not subsist in history, historical incidents or facts.
- Copyright does not subsist in scientific principles or descriptions of an art.
- Copyright does not subsist in mere principles or schemes.
- Copyright does not subsist in methods of operation.
- General ideas, e.g. for entertainment, are not protected by copyright.
- Ideas may nevertheless be protected through means other than copyright.

30. Copyright does not protect against deception: Copyright is not necessarily concerned with deception whereas deception forms the basis of unfair competition.

DESIGNER GUILD LTD v. RUSSELL WILLIAMS (TEXTILES) LTD

[2000] UKHL 58 [UK]

It must be borne in mind that this is an action for infringement of copyright. It is not an action for passing off. The gist of an action for passing off is deceptive resemblance. The defendant is charged with deceiving the public into taking his goods as and for the goods of the plaintiff. A visual comparison of the competing articles is often all that is required. If the overall impression is that 'they just do not look sufficiently similar' then the action will fail.

An action for infringement of artistic copyright, however, is very different. It is not concerned with the appearance of the defendant's work but with its derivation. The copyright owner does not complain that the defendant's work resembles his. His complaint is that the defendant has copied all or a substantial part of the copyright work. The reproduction may be exact or it may introduce deliberate variations – involving altered copying or colorable imitation as it is sometimes called. Even where the copying is exact the defendant may incorporate the copied features into a larger work much and perhaps most of which is original or derived from other sources. But while the copied features must be a substantial part of the copyright work, they need not form a substantial part of the defendant's work. Thus the overall appearance of the defendant's work may be very different from the copyright work. But it does not follow that the defendant's work does not infringe the plaintiff's copyright.

I. MORAL RIGHTS

31. *The Berne obligation in relation to moral rights:* The Berne Convention obliges Member States to recognize the moral rights of authors in these terms:

Independently of the author's economic rights, and even after the transfer of the said rights, the author shall have the right to claim authorship of the work and to object to any distortion, mutilation or other modification of, or other derogatory action in relation to, the said work, which would be prejudicial to his honor or reputation.

32. *The nature of moral rights:* Moral rights basically are the right to make the work public, the right of recognition as author, and the right of preserving the integrity of the work. How these rights are circumscribed are matters for local legislation and judicial interpretation. They may survive the death of the author.

AMAR NATH SEHGAL v UNION OF INDIA

2005 (30) PTC 253 [India]

In the material world, laws are geared to protect the right to equitable remuneration. But life is beyond the material. It is temporal as well. Many of us believe in the soul. Moral rights of the author are the soul of his works. The author has a right to preserve, protect and nurture his creations through his moral rights.

When an author creates a work of art or a literary work, it is possible to conceive of many rights which may flow. The first and foremost right which comes to one's mind is the 'paternity right' in the work, i.e. the right to have his name on the work. It may also be called the 'identification right' or 'attribution right'. The second right which one thinks of is the right to disseminate his work i.e. the "divulgence or dissemination right". It would embrace the economic right to sell the work for valuable consideration. Linked to the paternity right, a third right, being the right to maintain purity in the work can be thought of. There can be no purity without integrity. It may be a matter of opinion, but certainly, treatment of a work which is derogatory to the reputation of the author, or in some way degrades the work as conceived by the author can be objected to by the author. This would be the moral right of "integrity". Lastly, one can conceive of a right to withdraw from publication ones work, if author feels that due to passage of time and changed opinion it is advisable to withdraw the work. This would be the authors right to "retraction".

Except for the "divulgence or dissemination right", which perhaps is guided by commercial considerations, the other three rights originate from the fact that the creative individual is uniquely invested with the power and mystique of original genius, creating a privileged relationship between a creative author and his work.

33. *The different approaches to moral rights:* The approach to moral rights differs between common-law and civil-law jurisdictions. Generally speaking, the protection in civil-law countries is more extensive.

THEBERGE v GALERIE D'ART DU PETIT CHAMPLAIN INC

2002 SCC 34 [Canada]

The Act provides the respondent with both economic and 'moral' rights to his work. The distinction between the two types of rights and their respective statutory remedies is crucial.

Generally speaking, Canadian copyright law has traditionally been more concerned with economic than moral rights. Our original Act, which came into force in 1924, substantially tracked the English Copyright Act, 1911 (UK). The principal economic benefit to the artist or author was (and is) the ‘sole right to produce or reproduce the work or any substantial part thereof in any material form whatever’ for his or her life plus fifty years. The economic rights are based on a conception of artistic and literary works essentially as articles of commerce. (Indeed, the initial Copyright Act, 1709 was passed to assuage the concerns of printers, not authors.) Consistently with this view, such rights can be bought and sold either wholly or partially, and either generally or subject to territorial limitations, and either for the whole term of the copyright or for any part thereof. The owner of the copyright, thus, can be, but need not be, the author of the work.

Moral rights, by contrast, descend from the civil-law tradition. They adopt a more elevated and less dollars and cents view of the relationship between an artist and his or her work. They treat the artist’s *œuvre* as an extension of his or her personality, possessing a dignity which is deserving of protection. They focus on the artist’s right (which by s 14.1(2) is not assignable, though it may be waived) to protect throughout the duration of the economic rights (even where these have been assigned elsewhere) both the integrity of the work and his or her authorship of it (or anonymity, as the author wishes).

The important feature of moral rights in the present statute is that the integrity of the work is infringed only if the work is modified *to the prejudice of the honour or reputation of the author* (s 28.2(1)).

Unfortunately, the present text of the Copyright Act does little to help the promotion of the fusion of moral rights with the economic prerogatives of the law, since there is no comprehensive definition of copyright that embodies both. Section 3 of the Act, which is drafted as a definition of copyright, only refers to the economic dimension of copyright. Moral rights are defined and circumscribed in entirely distinct sections. This absence of cohesion leads to the separate mention of “copyright” and “moral rights” whenever Parliament wants to refer to both aspects of copyright law and to the near duplication of the provision on remedies for moral rights infringements.¹⁶⁰

160 See also *Desputeaux v. Éditions Chouette* [2003] 1 SCR 178, 2003 SCC 17 [Canada].

34. *The common-law approach:* Under Canadian law, for example, the author of a work has the right to the integrity of the work and the right, where reasonable in the circumstances, to be associated with the work as its author by name or under a pseudonym, and the right to remain anonymous.

However, the author's right to the integrity of a work is infringed only if the work is to the prejudice of the honor or reputation of the author, distorted, mutilated or otherwise modified; or used in association with a product, service, cause or institution.

35. *The civil-law approach:* According to the laws of the Netherlands, the author of a work has, even after assignment of copyright, the following moral rights:

- the right (which may be renounced) to prevent the communication to the public of the work without acknowledgement of his name or other indication as author, unless such opposition would be unreasonable;
- the right to prevent the communication to the public of the work under a name other than his own;
- the right (which may be renounced) to prevent any alteration in the name of the work or the indication of the author;
- the right (which may be renounced) to prevent any other alteration of the work, unless the nature of the alteration is such that opposition would be unreasonable;
- the right to prevent any distortion, mutilation or other impairment of the work that could be prejudicial to the name or reputation of the author or to his dignity.

In France, certain moral rights - unlike pecuniary rights which lapse 70 years after the death of the author - are perpetual, inalienable and not subject to limitation in terms of time, and they are transmitted to the author's heirs upon death.

CASE NUMBER: 2003(WA) NO.13385

(2005.6.23)

Tokyo District Court, 46th Civil Division

X, a sculptor, was asked by Y to produce two bronze statues. X complied but on the pedestal of both statues the name of Y appeared. X demanded of Y to confirm that X had the moral right (right of use of his name) and that Y had to inform the present owners that X was the author.

Although the defendant [Y] promised to pay the plaintiff for producing [the statues]; and after having requested to produce the bronze statues, had them produced actually, and thanked the plaintiff profusely, the defendant has recently alleged that the person who produced the bronze statues was actually the defendant and that the plaintiff was only an assistant. The plaintiff's pride was seriously harmed.

The plaintiff, as creator, should be entitled, as an appropriate measure, to demand of the defendant (Y) to inform the present owners of the bronze statues that the plaintiff is their creator. Requiring the defendant to inform the owners would ensure [the recognition of] the plaintiff as the creator, and prevent future disputes between the plaintiff and the owners, and would be an appropriate legal remedy.

COPYRIGHT: SUBSISTENCE OF COPYRIGHT

CHAPTER VIII

- A. FORMALITIES (1-2)
- B. OWNERSHIP (3-11)
- C. CRITERIA OF ELIGIBILITY FOR PROTECTION (12-15)
- D. WORK (16-21)
- E. ORIGINALITY (22-24)
- F. THE RELATIONSHIP BETWEEN "WORK" AND "ORIGINAL"
(25-26)
- G. FIXATION (27)
- H. PROVING SUBSISTENCE OF COPYRIGHT (28)

A. FORMALITIES

1. *The subsistence of copyright does not depend on formalities:* It is a general principle, established by the Berne Convention, that the subsistence of copyright may not be dependent on formalities such as registration. Some laws do provide for the possibility of registration, but that is for purposes of proof only: there is a presumption that the registration is valid; and that the registered owner does have copyright in the work deposited or described. Registration may also be required for purposes of enforcement as appears to be the case in the US.
2. *Effect on onus:* The fact that copyright is not registered means that a person who wishes to assert copyright must prove the subsistence of copyright. In connection with works such as computer programs, cinematographic works and the like it may be an arduous and expensive exercise.

VAGAR v TRANSAVALON (PTY) LTD

1977 (3) SA 766 (W) [South Africa]

Copyright is a technical subject. In my view it is essential that a person who claims to be the owner of a whole or partial copyright should offer evidence, even if it is hearsay evidence in circumstances that may justify the use of hearsay evidence, to cover the technical points necessary to establish his claim.

The “technical points” to establish copyright are discussed hereafter.¹⁶¹

B. OWNERSHIP

3. *Ownership and conferral of copyright:* Conferral of copyright and ownership of copyright do not necessarily coincide. There are three aspects to this, namely the wide meaning of the term “author”; the difference between “author” and “owner”; and the matter of transmissibility. These are dealt with in the subsequent paragraphs.

KING v SA WEATHER SERVICE

[2008] ZASCA 143

Copyright infringement is (subject to an irrelevant exception) actionable “at the suit of the owner of the copyright”. It is only actionable at the suit of the author if the author is also the owner.

¹⁶¹ *Toner v Kean Construction (Scotland) Ltd* [2009] ScotCS CSOH_105; *Forbes v Strathclyde Partnership for Transport & Anor* [2011] ScotCS CSOH_47.

The word “author” has a technical meaning; and the author is not necessarily the person who first makes or creates a work. It depends on the nature of the work. In the case of a computer program, the author is “the person who exercised control over the making of the computer program”.

The author of a work that attracts copyright is usually the first owner of the copyright but that need not necessarily be the case. An exception, which applies to computer programs amongst others, concerns the case of a work “made in the course of the author’s employment by another person under a contract of service”: in this event the employer is “the owner of any copyright subsisting in the work”. There is another relevant exception that concerns works which were made “by or under the direction or control of the state” – ownership of any such copyright initially vests in the state and not in the author.

4. *Wide meaning of author:* The concept of author is usually defined to include persons who are not the actual authors but persons responsible for the origin of the work. Although author, in relation to a literary, musical or artistic work, is the person who first makes or creates the work, the same does not necessarily apply to other works, e.g., in the case of a photograph, the author may be the person who was responsible for the composition of the photograph or the person who commissioned it; the author of a sound recording may be the person by whom the arrangements for the making of the sound recording were made; and the author of a cinematograph film may be the person by whom the arrangements for the making of the film are made.¹⁶²

5. *Author and owner:* The author is not necessarily the owner of the copyright in a work. Although the actual author is usually the first owner of copyright, the first owner may be someone else. For instance, copyright is often conferred on works made by or under the direction or control of the state or certain international organizations, and the ownership of any such copyright vests initially in the state or the international organization concerned, and not in the author.

6. *Employees:* The employer – and not the actual author – is often the first owner of any copyright subsisting in works made in the course of the author’s employment under a contract of service or apprenticeship. This kind of provision, which is typical in common-law jurisdictions, can also be found in civil-law countries such as Japan. There, the authorship of a work

162 There are other possibilities under Art.14*bis* of the Berne Convention.

(except a program work) which, on the initiative of an employer, is made by an employee in the course of his duties and is made public under the name of the employer as the author is attributed to the employer.

This principle is of general application to computer programs. German law provides an example: Where a computer program was created by an employee in the performance of his duties or following the instructions of his employer, the employer is entitled to exercise all economic rights that attach to the computer program, unless otherwise agreed.

In France, the employer's right to publish does not include the right to republish, the argument being that the existence of an employment contract does not waive the enjoyment of the originator's intellectual property rights; and in the absence of a specific agreement, concluded in accordance with the statutory conditions, an originator does not transfer the right to reproduce his work to his employer by the sole fact of the initial publication.¹⁶³

KING v SA WEATHER SERVICE

[2008] ZASCA 143

I accordingly proceed to consider whether the computer programs were authored by King "in the course of [his] employment by [the Bureau] under a contract of service". If the works were made in the course of his employment with the Bureau and ownership in the works accordingly vests in the state, King had no rights to enforce against the respondent.

The wording of s 21(1)(d) can be traced back to at least s 5(1)(b) of the British Copyright Act 1911. The phrase "in the course of employment" is a stock concept in employment law (formerly known as the law of master and servant). The term is unambiguous and does not require anything by way of extensive or restrictive interpretation. A practical and common sense approach directed at the facts will usually produce the correct result.

Agency law principles, which were developed in the context of tort law, do not necessarily fit the copyright context. The same may be said about the argument that the tests developed in the framework of vicarious liability should apply. Again, it appears to be wrong to apply delictual "principles" without more to determine questions of ownership in the arcane area of copyright especially since policy considerations must differ.

163 Cour de cassation (1 chambre civile), 12 juin 2001, *Rillon c/ Sté Capital Méda*.

Having regard to a number of judgments it appears to me to be dangerous to formulate generally applicable rules to determine whether or not a work was authored in the course of the employee's employment. It remains by and large a factual issue that depends not only on the terms of the employment contract but also on the particular circumstances in which the particular work was created.

7. *Independent contractors and commissioned works:* An author who is an independent contractor retains copyright.¹⁶⁴ Where a person commissions the taking of a photograph, the painting or drawing of a portrait, the making of a gravure, the making of a cinematograph film or the making of a sound recording, and pays or agrees to pay for it and the work is made in pursuance of that commission, the person who commissioned the work may be the owner of the copyright in the work.
8. *A person who performs a mere mechanical function is not the author.*¹⁶⁵

CALA HOMES v McALPINE

[1995] FSR 818 [UK]

In my view, to have regard merely to who pushed the pen is too narrow a view of authorship. What is protected by copyright in a drawing or a literary work is more than just the skill of making marks on paper or some other medium. It is both the words or lines and the skill and effort involved in creating, selecting or gathering together the detailed concepts, data or emotions which those words or lines have fixed in some tangible form which is protected. It is wrong to think that only the person who carries out the mechanical act of fixation is an author. There may well be skill and expertise in drawing clearly and well but that does not mean that it is only that skill and expertise which is relevant.

9. *Transmissibility and right of action:*¹⁶⁶ Copyright is transmissible by assignment or by operation of law, but, as mentioned, moral rights are not. The right of action (except in relation to moral rights) belongs to the owner, who may be an assignee or cessionary.

164 *Telephonic Communicators International Pty Ltd v Motor Solutions Australia Pty Ltd* [2004] FCA 942 [Australia].

165 *Cf Heptulla v MIS Orient Longman* 1989 PTC 157 [India].

166 *Crosstown Music Company 1, LLC v Rive Droite Music Ltd & Ors* [2010] EWCA Civ 1222.

FRANK & HIRSCH (PTY) LTD v A ROOPANAND BROTHERS (PTY) LTD

1993 (4) SA 279 (A) [South Africa]

[The Act] provides that copyright is transmissible as movable property by assignment; that an assignment of copyright may be limited so as to apply to some only of the acts which the owner of the copyright has the exclusive right to control, or to a part only of the term of the copyright, or to a specified country or other geographical area; and that no assignment of copyright shall have effect unless it is in writing signed by or on behalf of the assignor. The effect of a valid assignment is to vest in the assignee ownership of the copyright in the work or works covered by the assignment and entitles the assignee to sue for infringement of such copyright.

10. *Licensees*: Exclusive licensees may also have the right to claim without affecting the rights of the owner.

KLEP VALVES (PTY) LTD v SAUNDERS VALVE CO LTD

1987 (2) SA 1 (A) [South Africa]

Whereas the owner is the party who is primarily entitled to institute action against infringers, [the Act] grants to the licensee the rights of action and remedies of an assignee (which in effect are the same as the owner's). The section does not, however, say that the grant of rights to the exclusive licensee is to be accompanied by a corresponding diminution of the owner's rights, nor does it say that the exclusive licensee is to be regarded as in all respects equivalent to an assignee, which might have implied such a diminution. Purely as a matter of interpretation it would accordingly seem that the owner has not been deprived of *locus standi* in favor of the exclusive licensee.

This view is fortified if one has regard to the respective rights of the owner and the exclusive licensee. By granting an exclusive license, even in the widest possible terms, the owner does not lose his ownership. The practical value of his ownership might vary, but in most cases it would remain important since both his right to receive royalties from the licensee and his right of reversion if the license were to terminate for any reason, would depend on it. It seems unthinkable therefore that the Legislature would have intended to deprive the owner of the *locus standi* which he might need to protect the rights which he has retained despite the grant of an exclusive license.

11. *Joint authors:* Copyright Acts recognize the concept of joint authors.¹⁶⁷ Co-authors should litigate jointly.¹⁶⁸

FLYDE MICROSYSTEMS LTD v KEY RADIO SYSTEMS LTD

[1998] EWHC Patents 34 [UK]

Section 10(1) of the Copyright Designs and Patents Act 1988 defines a work of joint authorship as “a work produced by the collaboration of two or more authors in which the contribution of each author is not distinct from that of the other author or authors”. This provision does not turn someone who is not an author into an author. It is concerned to categorize works which are made from the input of two or more authors.

C. CRITERIA OF ELIGIBILITY FOR PROTECTION

12. *How copyright is conferred:* Copyright may be conferred under three alternative circumstances:

- if the author is a qualified person,
- by virtue of first publication, or
- state (crown) copyright.

13. *Qualified persons:* Copyright is conferred on every work, eligible for copyright, of which the author is, at the time the work is made, a qualified person. This applies to published and unpublished works. A qualified person is

- an individual who is a local citizen or is domiciled or resident within the jurisdiction; or
- a body incorporated under local laws.

In order to give effect to the requirement of national treatment, as required by the Berne Convention, citizens of a convention country or persons there domiciled or resident, and juristic persons there incorporated, are deemed to be qualified persons.

14. *First publication.* If the work was not made by a qualified author, copyright will be conferred on it if the work was first published either within the jurisdiction or in a convention country. The initial ownership of copyright

¹⁶⁷ *Brighton v Jones* [2004] EWHC 1157 [UK]; *Fisher v Brooker & Ors* [2009] UKHL 41.

¹⁶⁸ *Feldman NO v EMI Music SA (Pty) Ltd* 2010 (1) SA 1 (SCA).

conferred in these cases vests in the author unless the work was made in the course and scope of an employment contract or was commissioned.

15. State (crown) copyright: Copyright may also be conferred on a work made by or under the direction or control of the state or an international organization. In such event the initial copyright vests in the state or international organization and not in the author.

D. WORK

16. Types of works: Copyright laws have different approaches towards the definition of copyrightable works. Some laws distinguish between literary works;¹⁶⁹ musical works; artistic works; cinematographic films; sound recordings; broadcasts; program-carrying signals; and published editions (compilations). Each type of work is defined and the rights attaching to each circumscribed. These definitions are wide ranging.

Others, like Canada, define the term “original literary, dramatic, musical and artistic work” to every original production in the literary, scientific or artistic domain, whatever may be the mode or form of its expression, such as compilations, books, pamphlets and other writings, lectures, dramatic or dramatico-musical works, musical works, translations, illustrations, sketches and plastic works relative to geography, topography, architecture or science.

This is not much different from the civil tradition where the general term of the Berne Convention namely literary, scientific or artistic works is defined by means of a similar list, but there one finds that the definition is extended because the list is not exclusive and can “generally [include] any creation in the literary, scientific or artistic areas, whatever the mode or form of its expression” as in the Dutch definition.

17. The need to identify the “work”:

NOVA PRODUCTIONS LTD v MAZOOMA GAMES LTD

[2007] EWCA Civ 219 [UK]

First one must identify the artistic work relied upon and then decide whether it has been reproduced by copying of the work as a whole or of any substantial part of it. That is the effect of s. 3(1) and s. 16(1) of the Act. It is an aspect of UK copyright law untouched by any EU harmonization.

169 Computer programs must, by virtue of a TRIPS requirement, be protected as literary works.

MICROSOFT CORPORATION v PC CLUB AUSTRALIA PTY LTD

[2005] FCA 1522 [Australia]

Copyright protection is only available to what are referred to in the Copyright Act as “literary, dramatic, musical and artistic works” or “subject-matters other than works”. As a first step in bringing an action for infringement of copyright in a literary work, it is necessary to demonstrate that copyright subsists in that work.

18. *The definition of literary work.* It will be recalled that the Berne Convention uses an expansive and non-limiting definition of literary and artistic works to describe the works that are entitled to copyright protection because these works include every production in the literary, scientific and artistic domain, whatever may be the mode or form of expression, such as books, pamphlets and other writings and so forth.

In common-law jurisdictions literary works were, historically, defined to include irrespective of literary quality and in whatever mode or form expressed novels, stories and poetical works; dramatic works, stage directions, cinematograph film scenarios and broadcasting scripts; textbooks, treatises, histories, biographies, essays and articles; encyclopedias and dictionaries; letters, reports and memoranda; and lectures, speeches and sermons.

Currently English law defines it as any work, other than a dramatic or musical work, which is written, spoken or sung, and accordingly includes (a) a table or compilation, and (b) a computer program.

Dutch law is similar by granting copyright protection to books, pamphlets, newspapers, periodicals and all other writings.

19. *Expansive and unorthodox meaning of “literary”:* All these definitions attach a meaning to literary which is quite different from the orthodox dictionary meaning. Quality, especially literary quality, is not relevant.

UNIVERSITY OF LONDON PRESS LTD v UNIVERSITY TUTORIAL PRESS LTD

[1916] 2 Ch 601 [UK]

It may be difficult to define “literary work” as used in this Act, but it seems to be plain that it is not confined to “literary work” in the sense in which that phrase is applied, for instance, to Meredith’s novels add the writings of Robert Louis Stevenson. In speaking of such writings as literary works one thinks of the quality, the style, and the literary finish which they exhibit. Under the Act of 1842,

which protected “books”, many things which have no pretensions to literary style acquired copyright; for example, a list of registered bills of sale, a list of foxhounds and hunting days, and trade catalogues; and I see no ground for coming to the conclusion that the present Act was intended to curtail the rights of authors. In my view the words “literary work” cover work which is expressed in print or writing, irrespective of the question whether the quality or style is high. The word “literary” seems to be used in a sense somewhat similar to the use of the word “literature” in political or electioneering literature, and refers to written or printed matter.

20. *The definition of artistic work:* An artistic work in terms of copyright definitions is not necessarily artistic within the dictionary meaning of the word. These definitions also do not require any artistic value or even artistic intent. The term “artistic work” may refer to any

- graphic work, photograph, sculpture or collage, irrespective of artistic quality,
- work of architecture being a building or a model for a building, or
- work of artistic craftsmanship.

And “graphic work”, for example, could include any painting, drawing, diagram, map, chart or plan, and any engraving, etching, lithograph, woodcut or similar work.

NOVA PRODUCTIONS LTD v MAZOOMA GAMES LTD

[2006] EWHC 24 [UK]

It is to be noted that the definition of “graphic work” is inclusive. Paintings, drawings and the like are examples of graphic works protected by the Act but the definition is not restricted to the specific exemplars given.

KLEP VALVES (PTY) LTD v SAUNDERS VALVE CO LTD

1987 (2) SA 1 (A) [South Africa]

It is apparent therefore that, save for works of craftsmanship and architectural works, the items mentioned in the definition of “artistic work” do not in terms require any element of artistic endeavor. Indeed, the words used suggest a wider meaning, and where the Legislature wanted to introduce some specific artistic requirement for works of craftsmanship and architecture, it did so in express terms.

21. *Computer programs*: Computer programs are, in terms of the TRIPS Agreement, entitled to copyright protection as if they were literary works.

TELEPHONIC COMMUNICATORS PTY LTD v MOTOR SOLUTIONS PTY LTD

[2004] FCA 942 [Australia]

For the purposes of the Copyright Act 1968 a computer program is a “set of statements or instructions to be used directly or indirectly in a computer in order to bring about a certain result”. A computer program is a “literary work”. Subject to a number of qualifications the original author of a computer program has the copyright in that program. The copyright entitles the owner to various monopoly rights in relation to the program, including the right to reproduce and copy it, to make an adaptation of it, to publish it to the public and to enter into a commercial rental arrangement in relation to it. Breach of those monopoly rights is an infringement of the copyright. It is not necessary that the relevant reproduction be an exact copy. It is sufficient if there is a reproduction or copying of a “substantial part” of the program. Copyright is also infringed by the sale of the computer program without the permission of the copyright owner in circumstances where the person selling it knew, or should reasonably have known, that the making of the program was a breach of copyright.

E. ORIGINALITY

22. *Originality in the whole*: The inquiry is whether the work was original. The inquiry is not whether its parts were original. A work may be original even if its making involves the infringement of copyright in some other work. That would be the case where the work infringes by taking a substantial part of the premier work but, in addition, contains original material.

A second version of a work is entitled to its own copyright provided it differs in substance from the first (i.e. is not a mere copy). Where a defendant does not copy the plaintiff’s work but takes from it parts that are primarily commonplace, the plaintiff’s burden of proving originality in and infringement of his work may be more difficult than otherwise. This does not imply that the plaintiff’s work may be deconstructed.

HENKEL KG v HOLDFAST

[2006] NZSC 102 [New Zealand]

At this point it is desirable to say something about the approach of the Court of Appeal in the judgment delivered by Baragwanath J, with whom the other members of the Court appeared to agree on the issue we are about to address. We consider the Judge inappropriately deconstructed the copyright work. He did not treat it as a whole.

We think the Judge [suggested] that aspects of the design, strictly the drawing, were unoriginal. His method of expression in the context risks the appearance of confusing originality with novelty. Later the Judge correctly identified that the claimed originality lay in the arrangement of a number of unoriginal features. But the Judge then proceeded to say that the trial Judge had failed 'to remove from the collocation matters of no originality'. With respect, that is not the way to approach an arrangement case. If the Court were to do what Baragwanath J appears to have suggested, nothing would be left. An arrangement case is concerned with the author's arrangement of features which in themselves have no originality. The originality lies in the arrangement. To remove from the arrangement matters of no originality would, in these circumstances, leave nothing to arrange; all that would be left would be a blank sheet of paper.

23. *The common-law approach:* Typically, common-law jurisdictions that follow English precedents require a very low level of originality and have denigrated the requirement of originality to the question of whether the author has copied the work, also known as the sweat of the brow test.¹⁷⁰ "The originality which is required relates to the expression of the thought." The reason for the extensive interpretation approach may be the fact that English law does not recognize a general tort of unfair competition and that matters that could have been protected by such a tort are given the generous protection of copyright laws.

The approach of the US Supreme Court is different. Its test is this: "Original, as the term is used in copyright, means only that the work was independently created by the author (as opposed to copied from other works), and that it possesses at least some minimal degree of creativity."

Canadian jurisprudence is moving towards an intermediate position. This judgment of the Supreme Court of Canada deals with the opposing views and suggests a compromise.

170 *The Newspaper Licensing Agency Ltd & Ors v Meltwater Holding BV & Ors* [2010] EWHC 3099 (Ch).

CCH CANADIAN LTD v LAW SOCIETY OF UPPER CANADA

2004 SCC 13 [Canada]

The publishers of law reports alleged that the Law Society's library infringed its copyright by providing photocopies of the judgments or by providing the facility for members to make copies. One issue was whether the law reports were original. In this regard the Court found that the head-notes, the case summaries and the topical index were original but that the bodies of the reported judicial decisions were not, even if they were edited by the publishers.

There are competing views on the meaning of "original" in copyright law. Some courts have found that a work that originates from an author and is more than a mere copy of a work is sufficient to ground copyright. See, for example, *University of London Press Ltd v University Tutorial Press, Ltd* [1916] 2 Ch 601. This approach is consistent with the "sweat of the brow" or "industriousness" standard of originality, which is premised on a natural rights or Lockean theory [John Lock's] of "just desserts", namely that an author deserves to have his or her efforts in producing a work rewarded.

Other courts have required that a work must be creative to be "original" and thus protected by copyright. See, for example, *Feist Publications Inc v Rural Telephone Service Co* 499 US 340 (1991). This approach is also consistent with a natural rights theory of property law; however, it is less absolute in that only those works that are the product of creativity will be rewarded with copyright protection. It has been suggested that the "creativity" approach to originality helps ensure that copyright protection only extends to the expression of ideas as opposed to the underlying ideas or facts.

I conclude that the correct position falls between these extremes. For a work to be "original" within the meaning of the Copyright Act, it must be more than a mere copy of another work. At the same time, it need not be creative, in the sense of being novel or unique. What is required to attract copyright protection in the expression of an idea is an exercise of skill and judgement. By skill, I mean the use of one's knowledge, developed aptitude or practised ability in producing the work. By judgement, I mean the use of one's capacity for discernment or ability to form an opinion or evaluation by comparing different possible options in producing the work. This exercise of skill and judgement will necessarily involve intellectual effort. The exercise of skill and judgement required to produce the work must not be so trivial that it could be characterized as a purely

mechanical exercise. For example, any skill and judgement that might be involved in simply changing the font of a work to produce “another” work would be too trivial to merit copyright protection as an ‘original’ work.

In reaching this conclusion, I have had regard to: (1) the plain meaning of “original”; (2) the history of copyright law; (3) recent jurisprudence; (4) the purpose of the Copyright Act; and (5) that this constitutes a workable yet fair standard.

The plain meaning of the word “original” [point (1)] suggests at least some intellectual effort, as is necessarily involved in the exercise of skill and judgment. *Original’s* plain meaning implies not just that something is not a copy. It includes, if not creativity *per se*, at least some sort of intellectual effort. As Professor Gervais has noted,

“when used to mean simply that the work must originate from the author, originality is eviscerated of its core meaning. It becomes a synonym of ‘originated’, and fails to reflect the ordinary sense of the word.”

The idea of “intellectual creation” was implicit in the notion of literary or artistic work under the *Berne Convention*, to which Canada adhered in 1923, and which served as the precursor to Canada’s first *Copyright Act*, adopted in 1924. Professor Ricketson has indicated that in adopting a sweat of the brow or industriousness approach to deciding what is original, common law countries such as England have “depart[ed] from the spirit, if not the letter, of the [Berne] Convention” since works that have taken time, labor or money to produce but are not truly artistic or literary intellectual creations are accorded copyright protection. [Point (2).]

Although many Canadian courts have adopted a rather low standard of originality, i.e., that of industriousness, more recently, some courts have begun to question whether this standard is appropriate. The United States Supreme Court explicitly rejected the “sweat of the brow” approach to originality in *Feist, supra*. In so doing, O’Connor J explained that, in her view, the ‘sweat of the brow’ approach was not consistent with the underlying tenets of copyright law. [Point (3).]

As mentioned, in *Théberge* this Court stated that the purpose of copyright law [point (4)] was to balance the public interest in promoting the encouragement and dissemination of works of the arts and intellect and obtaining a just reward for the creator.

When courts adopt a standard of originality requiring only that something be more than a mere copy or that someone simply show industriousness to ground copyright in a work, they tip the scale in favor of the author's or creator's rights, at the loss of society's interest in maintaining a robust public domain that could help foster future creative innovation.

Requiring that an original work be the product of an exercise of skill and judgment is a workable yet fair standard [point (5)]. The "sweat of the brow" approach to originality is too low a standard. It shifts the balance of copyright protection too far in favor of the owner's rights, and fails to allow copyright to protect the public's interest in maximizing the production and dissemination of intellectual works. On the other hand, the creativity standard of originality is too high. A creativity standard implies that something must be novel or non-obvious – concepts more properly associated with patent law than copyright law. By way of contrast, a standard requiring the exercise of skill and judgment in the production of a work avoids these difficulties and provides a workable and appropriate standard for copyright protection that is consistent with the policy objectives of the Copyright Act.

24. *The civil-law approach.* The civil-law has a stricter approach. It requires some level of creativity.¹⁷¹ The work must carry the personal stamp of the author.

RUDOLPH JAN ROMME v VAN DALE LEXICOGRAPHIE BV

Hoge Raad, 4 January 1991, nr. 14 449 [The Netherlands]

The facts: The issue in this case concerned the legal question whether a collection of key words or lemmas could be entitled to copyright. The work concerned was the standard Dutch dictionary known as Van Dale. The Dutch Hoge Raad, sitting as a *cour de cassation*, had to decide the legal question. It held that such a work is entitled to copyright provided it has a unique and original character and if it bears the personal stamp of the author. The case was then referred back for a decision on the facts and Van Dale's copyright was upheld. It should be noted that the copyright in the dictionary itself was never in issue since everyone accepted that the bigger work consisting of the book (which defined the listed words) was entitled to copyright protection.

In the assessment of the argument it must first be said that, for a product to be regarded as a literary, scientific or artistic work

171 *Construction Denis Desjardins inc. c. Jeanson*, 2010 QCCA 1287 [Quebec].

as referred to in Article 1, in conjunction with Article 10, of the Copyright Act, it must have its own, original character and bear the personal stamp of the author.

A collection of words that form part of the Dutch language does not automatically meet this requirement, since in itself such a collection is no more than a quantity of factual data that, as such, does not qualify for copyright protection. The case would be different only if the collection were the result of a selection that expressed the author's personal view.

It cannot be deduced from the court's findings that there is such a selection in the present case. On the contrary, it refers only to "the treasury of words that form part of the Dutch language", in which respect, as far as the selection criteria are concerned, all that can be said is that they are words that merit inclusion in a modern dictionary such as the Grote Van Dale.

CASE NUMBER: 2003(WA)NO.12551, 2004(WA)NO.8021

Tokyo District Court, 47th Civil Division [Japan]

This case must be understood in the light of the definition of "work" in Japanese law, namely "work" means a production in which thoughts or sentiments are expressed in a creative way and which falls within the literary, scientific, artistic or musical domain. What is significant is the requirement of creativity.

The author and copyright owner of a book on law for the general public contended that the texts and charts in the defendant's work of the same nature are either identical or closely similar to his, and therefore violate his copyright.

Where the identical part of an existing copyrighted work and another work consist of statutes, circular notices, judgments, decisions and the like, which are not the subject matter of the copyright, it does not amount to a reproduction or adaptation. And in case where the identical part was the content of the statutes and naturally guided by [the terms of the] statute, precedent, or theory, it would also not be a case of reproduction and adaptation because the identical part is something other than the expression itself.

Although a graphic representation of the flow of procedure and content of a statute requires certain ingenuity, any diagram that is merely arranged based on the content of [a] statute would

inevitably be expressed [in a like manner] by anyone (unless there is a distinctive expression of arranging and summarizing from a unique perspective). Therefore, [if] the identical part in the diagram was merely [an] arrangement of [the] content of [the] statute, it is not a reproduction or adaptation because this is not a case where the part where thoughts or sentiments are expressed in a creative way are identical. Had it been otherwise it may prohibit others from giving a graphic representation of same flow of procedure based on the statute.

Moreover, if the identical part is the author's opinion or a general view regarding a certain legal issue, the identity is only in thought and idea and not in the creative way of expression. An opinion per se on certain legal issues does not amount to an expression which can be protected under copyright law and expressing the same opinion does not require to be prohibited under copyright law.

There are constraints in describing the content of a statute and the meaning of the legal terms and in referring to a general interpretation of the law and operation of practice concerning certain legal issues. That is because the established legal term must be used in the way previously defined or the general interpretation of law that is naturally guided by statute, precedent, or theory must be described.

Therefore, [unless] there is particular ingenuity in the expression from classifying from a unique aspect regardless of the order of the letter of the law or the arrangement and summarizing of exceptional expression, it would inevitably turn out a similar expression by anyone when concisely condensing the content of the laws, regulations, and the like by following the specified order of the laws and regulations or when giving explanation by using the definition of legal terms ordinarily used to describe them as in the text of laws and regulations or written in general book on law etc. In such cases, after all, it cannot be said that the author's personality is expressed. It would have to be said that the creativity in work protected by the copyright law is not recognized in here. In sum, in the case where identity is merely in the part that has no creative expression as mentioned above, it will not fall under the category of reproduction and adaptation.

On the other hand, although there is limitation in expression, in a case where a certain coherent unit of a specific expression is identical including order of description, it should be construed that there may be a case falling under infringement of reproduction right. In other

words, in a case where the range of creativity is small, when an identical part extends to a fixed quantity above a certain level even though there may be different expression, it should be construed as the infringement of a reproduction right.

OPERATING INSTRUCTIONS

BGH October 10, 1991 | ZR 147/89 [Germany]

From a legal point of view, the court below is correct to assume that the personal, intellectual creative input necessary for copyright protection in written works of a scientific and technical nature may find its expression primarily through the compilation, allocation and arrangement of available material.

The question of whether a written work possesses an adequate degree of individual creativity is thus answered according to the impression of intellectual creativity presented by the work in question as a whole in overall comparison with existing works. If overall comparison with previous known works establishes the presence of creative elements, these must be assessed against average creative activity. For a piece of writing intended to serve practical purposes to be eligible for copyright protection, it must in principle go significantly beyond the commonalities, manual processes and mechanical and technical arrangements involved in using the material. The lower requirements for eligibility for protection that apply to scientific and technical descriptions do not apply to written works of this type.

There is no legal objection to the position of the court below that the composition of the instruction manual, its mode of expression and other aspects of its presentation were largely prescribed by and conventional to its purpose. It was also right to deny that the typographical emphasis of headings, subsections and individual words and the monolingual nature of the instructions constituted individual creativity.

EXPLODED DIAGRAM

BGH February 28, 1991 | ZR 88/89 [Germany]

From a legal perspective, the court below was right to assume that the personal, intellectual creative input in scientific and technical descriptions must lie in the form itself. It was also right to accept that the requirement for individual creative form should not be set too high in the context of this condition: descriptions of this kind are

indeed protected under copyright despite regularly serving practical purposes that limit the latitude available for individual creation. It is therefore sufficient for there to be some expression of individual intellectual activity in the presentation over and above the norm for works created in the area of technical drawings, however small the extent of that individual creativity or character may be. However, a lesser degree of individuality nevertheless entails a lesser scope of protection for the work in question.

F. THE RELATIONSHIP BETWEEN “WORK” AND “ORIGINAL”

25. *“Original literary work” is a composite expression:*

EXXON CORP v EXXON INSURANCE CONSULTANTS LTD

[1982] Ch 119 (CA) [UK]

Original literary work, as used in the statute, is a composite expression, and for my part I do not think that the right way to apply a composite expression is, or at any rate is necessarily, to ascertain whether a particular subject matter falls within the meaning of each of the constituent parts, and then to say that the whole expression is merely the sum total of the constituent parts. In my judgment it is not necessary, in construing a statutory expression, to take leave of one’s common sense. That for which protection is sought in the instant case [copyright in the name EXXON] does not appear to me to have any of the qualities which commonsense would demand.

26. *The enquiries can be entwined and are objective:* A work has to be original. Whether an alleged work is proper subject-matter for copyright protection involves an objective test, both in respect of originality and work; and the two inquiries can become entwined. [The following case concerned the originality of a diary.]

WAYLITE DIARY CC v FIRST NATIONAL BANK LTD

1995 (1) SA 645 (A) [South Africa]

The types of works listed in the Act are “eligible for copyright” provided they are “original”. [That] presupposes, as a general rule, two different inquiries: first, whether the work relied upon falls within one of the categories and, if so, whether it was original. But, as pointed out by Blakeney and McKeough *Intellectual Property: Commentary and Materials* (1987) at 27:

“To some extent the concept of what constitutes a ‘work’ within the Act and the concept of originality are intertwined. It is difficult to discuss what amounts to a ‘work’ without discussing originality, since without a sufficient degree of ‘originality’ a ‘work’ will not come into existence.”

While it is true that the actual time and effort expended by the author is a material factor to consider in determining originality, it remains a value judgment whether that time and effort produces something original.

To illustrate the point reference may be made to *Francis Day and Hunter J Ltd v Twentieth Century Fox Corporation Ltd* [1940] AC 112 (PC). The copyright in the title of a song (written and composed by Fred Gilbert) called “The Man Who Broke the Bank at Monte Carlo” was an issue in the case. The title was subsequently used by the defendants for the name of a film. Lord Wright stated in this regard:

“As a rule, a title does not involve literary composition, and is not sufficiently substantial to justify a claim to protection. That statement does not mean that in particular cases a title may not be on so extensive a scale, and of so important a character, as to be a proper subject of protection against being copied. But this could not be said of the facts of the present case. There may have been a certain amount, though not a high degree, of originality in thinking of the theme of the song, and even in choosing the title, though it is of the most obvious. To *break a bank* is a hackneyed expression, and Monte Carlo is, or was, the most obvious place at which that achievement or accident might take place. The theme of the film is different from that of the song, and their Lordships see no ground in copyright law to justify the appellants’ claim to prevent the use by the respondents of these few obvious words, which are too unsubstantial to constitute an infringement, especially when used in so different a connection.”

It is implicit in this statement that whether an alleged work is proper subject –matter for copyright protection involves an objective test, both in respect of originality and “work”; also that the two inquiries can become entwined. And the last sentence quoted indicates that in assessing whether a work is entitled to protection, it is permissible to have regard to the consequences of the recognition of copyright in a work of doubtful substance.

G. FIXATION

27. Fixation is an optional requirement: According to the Berne Convention it is a matter for legislation of any particular country to prescribe that works in general or any specified categories of works will not be protected unless they have been fixed in some material form. (The terminology used in statutes differs in this regard.) As a general rule, works are not eligible for copyright in common-law countries unless they have been written down, recorded, represented in digital data or signals or otherwise reduced to a material form.¹⁷²

The rule does not apply to works that are not literary, dramatic or musical such as a broadcast or program-carrying signal; they require either a broadcast or transmission in order to be eligible for copyright.

CHEN WEIHUA v CHENGDU COMPUTER BUSINESS INFORMATION WEEKLY

Judgment No. (1999) 18

Intellectual Property Branch of Haidian District Court [Japan]:

The term “works” means intellectual creations with originality in the literary, artistic or scientific domain, and to the extent that they are capable of being reproduced in a tangible form. An intellectual creation should be fixed in a tangible medium of expression and kept stable enough to permit it to be reproduced or contacted by the public directly or with the help of some machines. The work is a literary description of 3D technology, in character of originality. Besides, it could be fixed in a digital format in the hard disc of a computer and uploaded onto the internet through a www server and kept stable enough to be accessed and reproduced by the public via any host. Therefore, the work is deemed to be a copyrightable work. The time of its first publication should be the time when it was first uploaded onto the personal homepage.

H. PROVING SUBSISTENCE OF COPYRIGHT

28. Proof of subsistence of copyright: It will immediately be clear that proving subsistence of copyright can be bothersome. It is consequently not surprising that most laws contain special provisions for alleviating this problem. There are three models (apart from oral evidence) but they are not exclusive or self-excluding:

¹⁷² *Green v Broadcasting Corp of New Zealand* [1989] RPC 469; *Bormley v EMI Records (Ireland) Ltd* [1998] IESC 44.

- registration (notification),¹⁷³
- affidavit evidence, and
- presumptions.

These matters are dealt with in the chapter on Copyright Piracy and are therefore omitted from this chapter.

173 See WIPO's survey on registration: http://www.wipo.int/copyright/en/registration/registration_and_deposit_system_03_10.html.

COPYRIGHT INFRINGEMENT

CHAPTER IX

- A. TYPES OF INFRINGEMENT (1-5)
- B. REPRODUCTION (6-12)
- C. CAUSAL CONNECTION (13)
- D. COPYING A SUBSTANTIAL PART (14-15)
- E. ADAPTATIONS (16)
- F. INDIRECT (SECONDARY) INFRINGEMENT (17-18)
- G. CONTRIBUTORY INFRINGEMENT (19)

A. TYPES OF INFRINGEMENT

1. *Nature of the work*: The rights accorded to owners and the ways in which these rights can be infringed differ depending on the type of the protected work. By the nature of things, the infringement of a literary work will for instance differ from that of a broadcast.

HENKEL KG v HOLDFAST

[2006] NZSC 102

A cause of action for breach of copyright necessarily involves clear and accurate identification of the copyright work in respect of which the defendant is said to have infringed. The early case of *Page v Wisden* (1869) 17 WR 483 exemplifies the principle. Malins VC said:

“when an author files a bill to protect a work, being only entitled to copyright in a small part of such work, he is bound to tell the defendant what that part is”.

[The] principle that accurate particulars are required in a copyright case is of general application. In the present case Henkel’s failure to plead the copyright work on which it is ultimately seeking to rely must result in its inability to rely on that work.

2. *Reproducing or copying*: The main form of infringement is reproducing or copying the copyright work. Pirated copies are, as a rule, copies of the whole of the work. The copying of a substantial part of a work – and not the whole – amounts to infringement. Determining the question of substantiality is often a difficult question of fact.

The adaptation of a work may also amount to an infringement. The term “adaptation” is usually defined in the statute. Under the broad term one could include the possibility of indirect reproductions: it is possible to reproduce indirectly, e.g., by making a three-dimensional representation of a two-dimensional artistic work.

3. *Direct and indirect infringement*. Copyright statutes as a rule define acts of infringement, e.g., reproducing or translating a literary work or performing it in public or broadcasting it. It is not feasible to discuss all these possibilities and the emphasis will be on a few aspects important for enforcement.

Copyright is infringed by any person, not being the owner of the copyright, who, without the license of the owner, does or causes any other person to

do, within the jurisdiction, any act which the owner has the exclusive rights to do or to authorize. Direct infringement refers to the performance of such an infringing act by the defendant.

Indirect infringement refers principally to the importation, with guilty knowledge, of goods that would have infringed the copyright had they been made within the country of importation.

FRANK & HIRSCH (PTY) LTD v A ROOPANAND BROTHERS (PTY) LTD

1993 (4) SA 279 (A) [South Africa]

If the person who made the article could not lawfully (i.e. without infringing copyright) have made it in South Africa, a person who, with the requisite knowledge and without license, either imports the article into South Africa or sells or distributes it here commits an infringement of copyright in terms of s 23(2).

This subject is dealt with in more detail later in this chapter. It is first necessary to determine what amounts to primary infringement because, in general terms, indirect infringement is not possible without primary infringement.

4. *The boundary between mere taking of general concepts and ideas and copying in the copyright sense:*¹⁷⁴

BAIGENT v THE RANDOM HOUSE GROUP LTD

[2007] EWCA Civ 247 [UK]

If material is found in a later work, which is also in an earlier copyright work, and it is shown that the author of the later work had access to the earlier work, an inference of copying is raised. Then it has to be considered whether there was in fact any copying, in relation to which the later author may say that he obtained the material from his own unaided efforts or from a different source. If it is found that any of the material common to both works was copied from the earlier work, then the question arises whether what was copied was a substantial part of the earlier work.

If the copyright work in question is a literary work, the allegation will normally be that part of the text of the earlier work was copied, exactly or with some modification, in the creation of the later work. In the present case that is not what is alleged as the basis for the claim in copyright infringement. What is said to have been copied is

174 *Allen v Bloomsbury Publishing Plc & Anor* [2010] EWHC 2560 (Ch).

a theme of the copyright work. Copyright does not subsist in ideas; it protects the expression of ideas, not the ideas themselves. No clear principle is or could be laid down in the cases in order to tell whether what is sought to be protected is on the ideas side of the dividing line, or on the expression side.

IPC MEDIA LTD v HIGHBURY-LEISURE PUBLISHING LTD

[2004] EWHC 2985 (Ch) [UK]

Needless to say, it is impossible to define the boundary between mere taking of general concepts and ideas on the one hand and copying in the copyright sense on the other. Judge Learned Hand in *Nichols v Universal Pictures Co* 45 F 2nd 119 (2nd Cir. 1930) said that wherever the line is drawn will seem arbitrary. He also said:

“Upon any work, and especially upon a play, a great number of patterns of increasing generality will fit equally well, as more and more of the incident is left out. The last may perhaps be no more than the most general statement of what the play is about, and at times may consist of only its title; but there is a point in this series of abstractions where they are no longer protected, since otherwise the playwright could prevent the use of his ‘ideas’, to which, apart from their expression, his property is never extended.”

HARMAN PICTURES NV v OSBORNE

[1967] 1 WLR 723 [UK]

One must, however, be careful not to jump to the conclusion that there has been copying merely because of similarity of stock incidents, or of incidents which are to be found in historical, semi-historical and fictional literature about characters in history. In such cases the plaintiffs, and that includes the plaintiffs in the present case, are in an obvious difficulty because of the existence of common sources.

5. “*What is worth copying is worth protecting*”: This is a commonly quoted axiom but it is dangerous and may beg the question.¹⁷⁵

175 See also *Lambretta Clothing Company Ltd v Teddy Smith (UK) Ltd* [2004] EWCA Civ 886.

NETWORK TEN PTY LIMITED v TCN CHANNEL NINE PTY LTD

[2004] HCA 14 [Australia]

Counsel invoked “the rough practical test that what is worth copying is *prima facie* worth protecting”. But later authorities correctly emphasize that, whilst copying is an essential element in infringement to provide a causal connection between the plaintiff’s intellectual property and the alleged infringement, it does not follow that any copying will infringe. The point was stressed by Laddie J when he said:

“Furthermore many copyright cases involve defendants who have blatantly stolen the result of the plaintiff’s labors. This has led courts, sometimes with almost evangelical fervor, to apply the commandment ‘thou shalt not steal’. If that has necessitated pushing the boundaries of copyright protection further out, then that has been done. This has resulted in a body of case law on copyright which, in some of its further reaches, would come as a surprise to the draughtsmen of the legislation to which it is supposed to give effect.”

JHP LTD v BBC WORLDWIDE LTD

[2008] EWHC 757 (Ch) (16 April 2008)

Although [counsel] referred me to the practical test that “what was worth copying was *prima facie* worth protecting”, so that I should start with a bias towards anything that was “copied” being “substantial”, I have not found that test useful. I think it tends to confuse questions of “copying” with questions of “substantiality”, and to proceed upon the premise that if the text was “worth” copying for the Guide it was *prima facie* a substantial part of the relevant Book (which seems to me to focus on the importance of the text to the Guide rather than on the importance of the text to the whole of the relevant Book).

B. REPRODUCTION

6. *The meaning of “reproduction”:* The main form of copyright infringement consists of the reproduction of the work concerned.

The term “reproduction” is not defined in the Berne Convention. It is, however, understood that the reproduction right, as set out in Art. 9 of the Berne Convention, and the exceptions permitted thereunder, fully apply in

the digital environment, in particular to the use of works in digital form. The storage of a protected work in digital form in an electronic medium, it is also understood, constitutes a reproduction within the meaning of Article 9 of the Berne Convention.¹⁷⁶

ROBERTSON v THOMSON CORP

2006 SCC 43 [Canada]

Article 9 of the *Berne Convention* guarantees authors a right of reproduction of works “in any manner or form”, which the *WIPO Guide to the Copyright and Related Rights Treaties Administered by WIPO and Glossary of Copyright and Related Rights Terms* (2003), at p. 55, develops as follows:

“The text of the Berne Convention does not contain any complete and explicit definition of ‘reproduction’. Certain elements of the concept of reproduction may, however, be identified in it. A good example is the clarification offered in Article 9(3) [sound or visual recordings deemed to be reproductions] which makes it obvious that it is not a condition that, on the basis of the reproduction, the copy of the work be directly perceivable; it is sufficient if the reproduced work may be made perceivable through appropriate equipment.”

7. Reproduction involves the making of a copy or copies:

THEBERGE v GALERIE D’ART DU PETIT CHAMPLAIN INC

2002 SCC 34 [Canada]

We are required in this appeal to determine the extent to which an artist, utilizing the statutory rights and remedies provided by the Copyright Act, can control the eventual use or display of an authorized reproduction of his or her work in the hands of a third party purchaser.

The historical scope of the notion of “reproduction” under the Copyright Act should be kept in mind. As one would expect from the very word “copyright”, “reproduction” is usually defined as the act of producing additional or new copies of the work in any material form. Multiplication of the copies would be a necessary consequence of this physical concept of “reproduction”.

176 Agreed Statements concerning the WIPO Copyright Treaty: <http://www.wipo.int/treaties/en/ip/wct/statements.html>

A similar understanding of “reproduction” is reflected in decisions under the English Act on which s 3(1) of our Act is based, i.e., the physical making of something which did not exist before.

8. *To reproduce does not require exact replication:*

SPECTRAVEST INC v APERKNIT LTD

[1988] FSR 161 [UK]

Reproduction does not mean exact replication. A man may use another’s work as an inspiration to make a new work of his own, treating the same theme in his own manner; but he is not entitled to steal its essential features and substance and retain them with minor and inconsequential alterations. The question is whether there is such a degree of similarity between the salient features of the two works that the one can be said to be a reproduction of the other. In considering whether a substantial part of the plaintiffs’ work has been reproduced by the defendant, attention must primarily be directed to the part which is said to have been reproduced, and not to those parts which have not.

9. *Reproduction includes reproduction of a work by its storing in digital form:*¹⁷⁷

ROBERTSON v THOMSON CORP

2006 SCC 43 [Canada]

That there is no loss of copyright by virtue of reproduction in digital storage form, such as databases, is further confirmed by an Agreed Statement concerning Art. 1(4) of the WIPO Treaty which is set out in a footnote to that article:

“The reproduction right, as set out in Article 9 of the Berne Convention, and the exceptions permitted thereunder, fully apply in the digital environment, in particular to the use of works in digital form. It is understood that the storage of a protected work in digital form in an electronic medium constitutes a reproduction within the meaning of Article 9 of the Berne Convention.”

177 Agreed Statements concerning the WIPO Copyright Treaty: <http://www.wipo.int/treaties/en/ip/wct/statements.html>: “It is understood that the mere provision of physical facilities for enabling or making a communication does not in itself amount to communication within the meaning of this Treaty or the Berne Convention.”

Just as individual authors do not lose copyright in their articles by virtue of their inclusion in an electronic database, newspaper publishers do not lose their right to reproduce their newspaper, including the articles that comprise it, by doing the same.

The fact that the actual newspaper page is not fully or identically reproduced in the database and the articles are therefore presented in a different form from a *paper* newspaper is irrelevant. It is not the physical manifestation of the work that governs; it is whether the product perceivably reproduces the exercise of skill and judgment by the publishers that went into the creation of the work.

10. *“Reproduction of the whole” involves few substantial factual or legal issues:* It is factually unlikely that a copy of any substantial work will not have been derived from the original unless the original is not truly original and both works are derived from another source.

BILHOFER MASCHINENFABRIK GMBH v TH DIXON & CO LTD

[1990] FSR 105:

It is the resemblances in *inessentials*, the small, redundant, even mistaken elements of the copyright work, which carry the greatest weight. This is because they are least likely to have been the result of independent design.

CREATIVE TECHNOLOGY LTD v AZTECH SYSTEMS PTE LTD

[1997] FSR 491 [Singapore]

Next, we turn to the literal similarities which exist (including the programming errors) between the respective firmware of the parties, when viewed *in toto*, raise the irresistible inference that the chances of independent development on the part of Aztech were low. We find that Aztech have failed to provide a reasonable explanation, one that is consistent with the absence of any copying through disassembly. In our view the learned Judicial Commissioner failed to address the question of the cumulative weight and significance of all the similarities in reaching his decision, including similarities in non-essentials and errors.

11. *To be actionable the copy must be a substantial and material one:*

RG ANAND v MIS DELUX FILMS¹⁷⁸

(1978) 4 SCC 118 [India]

Where the same idea is being developed in a different manner, it is manifest that the source being common, similarities are bound to occur. In such a case the courts should determine whether or not the similarities are on fundamental or substantial aspects of the mode of expression adopted in the copyrighted work. If the defendant's work is nothing but a literal imitation of the copyrighted work with some variations here and there it would amount to violation of the copyright.

In other words, in order to be actionable the copy must be a substantial and material one which at once leads to the conclusion that the defendant is guilty of an act of piracy.

12. *Two-dimensional drawings may be reproduced by three-dimensional articles:*

KING FEATURES SYNDICATE INC v O AND M KLEEMAN LTD

[1940] 2 All ER 355 (Ch) [UK]

There can be no doubt at all that a figure which in fact reproduces an original artistic work consisting, in substance, of a sketch of that figure, is none the less a reproduction of the original artistic work, because the maker of it has copied it not directly from the original but from some representation derived directly or indirectly from the original work. It seems to have been suggested in the court below that the fact that the alleged infringement was in three dimensions, whereas the original was in two, prevented the plaintiffs making good their claim. I agree with the learned judge that while this circumstance may add to the difficulty of forming a conclusion on the degree of resemblance between the infringing article and the original, the plain words of the Act ('in any material form') get rid of any difficulty there might otherwise have been in treating a copy in three dimensions as an infringement of copyright in a sketch in two dimensions.

178 Quoted in *Gupta v Dasgupta* [2003] FSR 18 (HC) [India].

C. CAUSAL CONNECTION

13. *Causal connection:* Reproduction requires not only the production of the same work, but also that it must have been copied, i.e., there must be a causal connection between the copyright work and the copy.¹⁷⁹

HENLEY ARCH PTY LTD v CLARENDON HOMES (AUST) PTY LTD

(1998) 41 IPR 443 [Australia]

The question of reproduction for the purposes of copyright law involves the two elements of resemblance to, and actual use of, the copyright work. These elements have been described as “a sufficient degree of objective similarity between the two works” and “some causal connection between the plaintiffs’ and the defendants’ work”. There is no reproduction for the purposes of the Act where two persons produce substantially similar works through independent effort.

UNIVERSITY OF WAIKATO v BENCHMARKING SERVICES LTD

[2004] NZCA 90 [New Zealand]

It is common ground that there are three requirements to establish infringement by copying in the form of reproduction:

- The reproduction must be either of the entire work or of a substantial part;
- There must be sufficient objective similarity between the infringing work and the copyright work, or a substantial part thereof;
- There must be some causal connection between the copyright work and the infringing work. The copyright must be the source from which the infringing work is derived.

CREATIVE TECHNOLOGY LTD v AZTECH SYSTEMS PTE LTD

[1997] FSR 491 [Singapore]

The burden of proof does remain with the plaintiff in an infringement claim, to prove copying and access to his work, and, where there is sufficient resemblance shown between the two works, he will invite the court to draw an inference of copying. The defendant then has the opportunity to rebut the inference; to give an alternative explanation of the similarities where this is possible; and at this point, in our view, the burden shifts.

¹⁷⁹ *Baigent & Anor v The Random House Group Ltd* [2007] EWCA Civ 247 [UK]; *Toy Major Trading Co v Hang Shun Plastic Toys* Civil Appeal No. 11 of 2007 [Hong Kong Special Administrative Region].

The copyright owner must essentially show that 'causal connection' is the explanation of the similarity between the work and infringement – but there are other possibilities which may be pleaded by way of defense; that the plaintiff copied from the defendant, that they both copied from a common source, or that they arrived at their respective results independently. The relevant question in our case is this: whether the inference of copying could be displaced by evidence from Aztech how in fact they had arrived at their design and that they had not done so by copying?

The above statement must not be read to mean that the copyright plaintiff is awarded a lower standard of proof. He must still run his case in the most thorough and best way he can, to show the existence of probative similarities leading to the inference of copying, whereupon the opportunity then arises for the defendant to explain those difficulties away.

D. COPYING A SUBSTANTIAL PART

14. *Copying a substantial part:* The copying of a substantial part of a copyrighted work amounts to infringement. This may raise difficult factual questions. The Berne Convention provides some guidance in this regard in Art. 10:

- It shall be permissible to make quotations from a work which has already been lawfully made available to the public, provided that their making is compatible with fair practice, and their extent does not exceed that justified by the purpose, including quotations from newspaper articles and periodicals in the form of press summaries.
- It shall be a matter for legislation in the countries of the Union, and for special agreements existing or to be concluded between them, to permit the utilization, to the extent justified by the purpose, of literary or artistic works by way of illustration in publications, broadcasts or sound or visual recordings for teaching, provided such utilization is compatible with fair practice.
- Where use is made of works in accordance with the preceding paragraphs of this Article, mention shall be made of the source, and of the name of the author if it appears thereon.

GILHAM v REGINA

[2009] EWCA Crim 2293.

“Substantial” is a difficult word. It may indeed mean “not insubstantial”. But another dictionary meaning is “of ample or considerable amount, quantity, or dimensions”.

NETWORK TEN PTY LIMITED v TCN CHANNEL NINE PTY LTD

[2004] HCA 14 [Australia]

The term “substantial part” has a legislative pedigree [and] keeps separate the concepts of substantial part and fair dealing. Accordingly:

“acts done in relation to insubstantial parts do not constitute an infringement of copyright and the defenses of fair dealing only come into operation in relation to substantial parts or more.”

It would be quite wrong to approach an infringement claim on the footing that the question of the taking of a substantial part may be by-passed by going directly to the fair dealing defenses.

As already emphasized in these reasons, the requirement that an infringer who takes less than the whole of the protected subject-matter must take at least a substantial part thereof plays a well-established and central part in copyright law. Questions of quality (which could include the potency of particular images or sounds, or both, in a broadcast) as well as quantity arise.

15. *The test is qualitative and not quantitative.*

LADBROKE (FOOTBALL) LTD v WILLIAM HILL (FOOTBALL) LTD

[1964] 1 All ER 465 (HL)

If he does copy, the question whether he has copied a substantial part depends much more on the quality than on the quantity of what he has taken. One test may be whether the part which he has taken is novel or striking, or is merely a common-place arrangement of ordinary words or well-known data.

The more correct approach is first to determine whether the plaintiff’s work as a whole is “original” and protected by copyright, and then to enquire whether the part taken by the defendant is substantial. A wrong result can easily be reached if one begins by dissecting the

plaintiff's work and asking, could section be the subject of copyright if it stood by itself, could section be protected if it stood by itself, and so on.

To my mind, it does not follow that because the fragments taken separately would not be copyright, therefore the whole cannot be. Indeed, it has often been recognized that if sufficient skill and judgment have been exercised in devising the arrangement of the whole work, that can be an important or even decisive element in deciding whether the work as a whole is protected by copyright.

There are two instances to be considered under this head: first, where an identifiable part is taken and, second, where there is an alteration of the original.

DESIGNER GUILD LTD v RUSSELL WILLIAMS (TEXTILES) LTD

[2000] UKHL 58 (HL) [UK]

Section 16(3) of the 1988 Act says that copying a copyright work is a copyright infringement if the copying is of "the work as a whole or any substantial part of it". Section 16(3) may come into play in two quite different types of case. One type of case is, obviously, where an identifiable part of the whole, but not the whole, has been copied. For example, only a section of a picture may have been copied, or only a sentence or two, or even only a phrase, from a poem or a book, or only a bar or two of a piece of music, may have been copied. In cases of that sort, the question whether the copying of the part constitutes an infringement depends on the qualitative importance of the part that has been copied, assessed in relation to the copyright work as a whole.

The other type of case in which a question of substantiality may become relevant is where the copying has not been an exact copying of the copyright work but a copying with modifications. This type of copying is referred to in Laddie¹⁸⁰ as "altered copying". A paradigm of this type of case would be a translation of a literary work into some other language, or the dramatization of a novel. The translation, or the play or film, might not have a single word in common with the original. But, assuming copyright existed in the original, the "copy" might well, and in the case of a word-by-word translation certainly would, constitute an infringement of copyright.

E. ADAPTATIONS

16. *Definition of adaptation:* Adaptation of a work involves producing a different version of the work incorporating the same product of originality. The term is usually defined in the relevant Copyright Act. In relation to a literary work, “adaptation” may include the conversion of a non-dramatic work, such as a novel, into a dramatic work or vice versa. The Berne Convention (Art. 2(3)) provides in this regard that “translations, adaptations, arrangements of music and other alterations of a literary or artistic work shall be protected as original works without prejudice to the copyright in the original work.”

BENCHMARK BUILDING v MITRE 10 (NEW ZEALAND) LTD

[2003] NZCA 213 [New Zealand]

Counsel’s argument equated the copyright works with the brochures. It was submitted that Benchmark had adapted the brochures for its own purpose. However, this misconceives the nature of the restricted act. It is not directed to using the copyright works or reproductions of them. The act of infringement is the making of an adaptation of the work. Infringement in this way [i.e., making an adaptation] can occur only in respect of literary, dramatic or musical works. It does not apply to artistic works. We must, therefore, concentrate on the written matter in the brochures which might constitute literary works.

Making an adaptation of a work involves producing a different version of the work incorporating the same product of originality of the author but expressing it in a manner which cannot be characterized as copying or reproduction but still presents substantially the same work. Writing a play or film script from a novel, producing object code from a computer program source code, are typical examples. As noted in Laddie,¹⁸¹ what matters is that the intellectual content of the original work has been taken. Making an adaptation of a work is quite different from making use of a work (or of reproductions of a work). Section 34(2) provides that an adaptation is made when it is recorded, in writing or otherwise. That language makes clear that more is involved than merely taking and using the original work without change.”

181 Laddie, Prescott & Vitoria, *The Modern Law of Copyright and Designs*.

CASE NUMBER: 2005(NE) NO.10023

[2005.6.14]

Intellectual Property High Court, Second Division [Japan]

“Adaptation” under the Copyright Law is an act of creating a separate work by modifying, adding/subtracting, changing, etc., a specific expression, based on an existing work while maintaining the same essential expression of the existing work, so as to creatively express a new thought or feeling. Under this Article, a person exposed to this separate work must be able to directly perceive the essential expression of the existing work. Along these lines, if a work created based on an existing work is merely identical to the existing work with respect to an aspect which is not in itself an expression or which has no expressional creativity, such as any thought, feeling or idea, or fact or incident in the existing work it work is not an adaptation. The “Seven Samurai” is a work that is much more artistic than “MUSASHI” and these works have similarities or commonalities in their ideas only. The essential expression of the “Seven Samurai” cannot be perceived from “MUSASHI”. Therefore, the similarities or commonalities do not constitute an infringement of the copyright (right of adaptation) or of the author’s moral rights (right of attribution and right of integrity).

F. INDIRECT (SECONDARY) INFRINGEMENT

17. *Direct (primary) and indirect (secondary) infringement:* The basic distinction between direct and indirect (or primary and secondary) infringement has been set out at the beginning of the chapter. Secondary infringement is, principally, the case of dealing with or the importation of infringing products with the requisite degree of knowledge.¹⁸²

EURO-EXCELLENCE INC v KRAFT CANADA INC

2007 SCC 37 [Canada]

The Kraft companies thus allege that Euro-Excellence has engaged in ‘secondary infringement’ by importing for sale or distribution copies of KFS and KFB’s copyrighted works into Canada. Secondary infringement is dealt with under s. 27(2) of the Act.

Three elements must be proven to establish secondary infringement: (1) a primary infringement; (2) the secondary infringer should have known that he or she was dealing with a product of infringement;

182 Katsunari Goto *Indirect Infringement’ of Copyrights in a Multimedia Society*: http://www.cric.or.jp/cric_e/cuj/cuj98/cuj98_4.html.

and (3) the secondary infringer sold, distributed or exposed for sale the infringing goods. Perhaps the most straightforward form of secondary infringement arises when one sells a copy of an infringing work. Under s. 27(2)(a), '[i]t is an infringement of copyright for any person to ... sell ... a copy of a work ... that the person knows or should have known infringes copyright'.

Section 27(2)(e) stands out as an apparent exception to the rule in *CCH* that secondary infringement first requires primary infringement because, unlike s. 27(2)(a) to (d), it does not require *actual* primary infringement. Instead, it requires only *hypothetical* primary infringement. Under s. 27(2)(e),

It is an infringement of copyright for any person to... import...a copy of a work...that the person knows...*would infringe copyright if it had been made in Canada by the person who made it.*

Section 27(2)(e) substitutes hypothetical primary infringement for actual primary infringement. It is possible that the infringing imports may have been lawfully made outside of Canada. Still, they are deemed to infringe copyright if the importer has imported into Canada works that *would have infringed* copyright if those works had been made in Canada by the persons who made the works abroad.

The apparent purpose of s. 27(2)(e) is to give Canadian copyright holders an added layer of protection where the Canadian copyright holder does not hold copyright in that work in foreign jurisdictions. Section 27(2)(e) protects Canadian copyright holders against 'parallel importation' by deeming an infringement of copyright even where the imported works did not infringe copyright laws in the country in which they were made.

18. *Knowledge or deemed knowledge:* Knowledge or deemed knowledge is usually required for indirect infringement. It is not required for direct infringement.

BAIGENT & ANOR v THE RANDOM HOUSE GROUP LTD

[2007] EWCA Civ 247 [UK]

Breach of copyright does not depend on intention or knowledge (though these may be relevant in some cases to remedy).

The question now is whether there has been copying, not what the intention of the copier was in doing it. If the alleged infringer denies copying, and is disbelieved, then what matters is the finding of fact as to copying which follows, though no doubt his being disbelieved may also have other forensic effects as to the findings made by the judge in the case.

I cannot see how the intention with which any copying was done is or can be legally relevant to the issue whether the copying is an infringement, either generally or by reference to the question whether what was copied is a substantial part of the copyright work.

POLYGRAM RECORDS v RABEN FOOTWEAR

[1996] 797 FCA 1

The final requirement for [secondary] infringement under s 102 and s 103 is that the importer must have knowledge or deemed knowledge as required by those sections. The requirement in s 102 is that:–

the importer knew, or ought reasonably to have known, that the making of the article would, if the article had been made in Australia by the importer, have constituted an infringement of the copyright.

Therefore the question in relation to knowledge required to be answered in these proceedings can be formulated thus: did Raben know, or ought it reasonably to have known, that if it had made each of the Pilz CDs in Australia, that making would have constituted an infringement of the sound recording copyright in the PolyGram recordings (i.e. the Cher songs)?

It is irrelevant in this regard whether the making of the CDs in their country of origin constituted an infringement of copyright. Moreover, there is no requirement that Raben must have (or ought to have) known that the sound recording copyright infringed was that of the applicants.

MILPURRURRU v INDOFURN

(1994) 30 IPR 209

Knowledge refers to notice of facts such as would suggest to a reasonable person having the ordinary understanding expected of persons in the particular line of business that a breach of copyright was being committed. Knowledge of the law is not required. It

is sufficient that there be actual or constructive knowledge that intellectual property rights would be infringed, without knowing the precise nature of those rights’.

G. CONTRIBUTORY INFRINGEMENT

- 19.** This issue is discussed in the context of criminal enforcement.

COPYRIGHT DEFENSES

CHAPTER X

1. *Constitutional considerations. Freedom of speech and the press:* Jurisdictions that have a constitutionally protected right to free speech (including the freedom of the press) may have to consider whether a particular copyright claim may be affected or inhibited by constitutional considerations. A constitutional complaint concerning a copyright dispute requires a balancing of intellectual property rights with freedom of expression and press freedom.

BUNDESGERICHTSHOF I ZR 191/08183

This provision of the Copyright Act is based on Article 6 of Directive 2001/29/EC on the harmonization of certain aspects of copyright and related rights in the information society. Under of this Directive, Member States undertake to provide appropriate sanctions and remedies for violations of the rights and obligations laid down in the Directive.

The sanctions must be effective, proportionate and dissuasive. In the interpretation of the Directive and the implementation of national law, fundamental rights to freedom of expression and freedom of reporting may only be restricted in accordance with the principle of proportionality.

The protection of freedom of the press covers the protection of freedom of the law, the subject of reports to choose freely. It is not for the courts to determine whether a particular issue is at all newsworthy or not. The protection of fundamental rights includes freedom of expression and press freedom in all its dimensions. It covers not only the content but also in the form of expression or reporting.

ASHDOWN v TELEGRAPH GROUP LTD

[2001] EWCA Civ 1142 [UK]

The infringement of copyright constitutes interference with “the peaceful enjoyment of possessions”. It is, furthermore, the interference with a right arising under a statute which confers rights recognized under international convention and harmonized under European law. There is thus no question but that restriction of the

183 Bundesgerichtshof I ZR 191/08 Verkündet am 14. Oktober 2010, a judgment upheld by the German Constitutional Court (Bundesverfassungsgericht): BVerfG, 1 BvR 1248/11 vom 15.12.2011, Absatz-Nr. (1 - 38), http://www.bverfg.de/entscheidungen/rk20111215_1bvr124811.html. Freely translated.
On the question of censorship by internet service providers see: Edwards *WIPO Study on the Role & Responsibility of Internet Intermediaries in the field of Copyright & Related Rights* p 12: http://www.wipo.int/export/sites/www/copyright/en/doc/role_and_responsibility_of_the_internet_intermediaries_final.pdf

right of freedom of expression can be justified where necessary in a democratic society in order to protect copyright. The protection afforded to copyright under the 1988 Act is, however, itself subject to exceptions. Thus both the right of freedom of expression and copyright are qualified. This appeal raises the question of how the two rights fall to be balanced, when they are in conflict.

It is important to emphasize in the present context that it is only the form of the literary work that is protected by copyright. Copyright does not normally prevent the publication of the information conveyed by the literary work. Thus it is only the freedom to express information using the verbal formula devised by another that is prevented by copyright. This will not normally constitute a significant encroachment on the freedom of expression. The prime importance of freedom of expression is that it enables the citizen freely to express ideas and convey information. It is also important that the citizen should be free to express the ideas and convey the information in a form of words of his or her choice. It is stretching the concept of freedom of expression to postulate that it extends to the freedom to convey ideas and information using the form of words devised by someone else.

Freedom of expression protects the right both to publish information and to receive it. There will be occasions when it is in the public interest not merely that information should be published, but that the public should be told the very words used by a person, notwithstanding that the author enjoys copyright in them. On occasions, indeed, it is the form and not the content of a document which is of interest.

We do not consider that this conclusion will lead to a flood of cases where freedom of expression is invoked as a defense to a claim for breach of copyright. It will be very rare for the public interest to justify the copying of the form of a work to which copyright attaches.

2. *Fair dealing and fair use justification:* Copyright laws generally provide for, what is sometimes referred to as, a fair dealing exception to copyright infringement.

Article 9(2) of the Berne Convention (1967 revision) states in this regard that national legislation may permit the reproduction of works in certain special cases, provided that such reproduction does not conflict with a normal exploitation of the work and does not unreasonably prejudice the legitimate interests of the author. Article 13 of the TRIPS Agreement is in similar terms:

“Members shall confine limitations or exceptions to exclusive rights to certain special cases which do not conflict with a normal exploitation of the work and do not unreasonably prejudice the legitimate interests of the right holder.”

Otherwise stated, fair dealing may be legitimate.

The three Berne requirements are cumulative and are to be applied one after the other. They have been formulated in these terms:¹⁸⁴

- Exemptions are permitted in special cases. Berne does not allow broad exemptions, but only in respect of quite specific purposes. “Special” means a justification by some clear reason of public policy or some other exceptional circumstance.
- The exemption may not be in conflict with the normal exploitation of the work.
- The copyright owner may not be unreasonably prejudiced.

3. Application of the Berne requirements: This analysis is perceivable in a number of laws, especially in the civil tradition, such as China, France, Portugal and Spain but also now in Australian law where, by virtue of a recent amendment, the Copyright Act provides that the copyright in a work or other subject matter is not infringed by a use of the work or other subject matter if all the following conditions exist: the circumstances of the use must amount to a special case; the use is by libraries and archives, educational institutions, or use by or for a person with a disability; the use does not conflict with a normal exploitation of the work or other subject matter; and the use does not unreasonably prejudice the legitimate interests of the owner of the copyright.

The effect of this type of provision is that a court must assess in each instance whether all these conditions exist. Other countries interpret the Berne Convention differently.

4. Further applicable Convention provisions: Conventions in addition permit a number of special exceptions or limitations on the rights of authors.¹⁸⁵

The Berne Convention provides that legislation may exclude protection for political speeches and speeches delivered in the course of legal proceedings and may prescribe conditions under which lectures, addresses and other works of the same nature which are delivered in public may be reproduced (Art. 2*bis*).

184 Cohen Jehoram *Restrictions on copyright and their abuse* [2005] EIPR 359; Ricketson *The Berne Convention 1886-1996* p 482.

185 See further Article 15 Rome Convention; Article 13 TRIPS Agreement; Article 10 WCT; Article 16 WPPT.

Apart from special provisions relating to the possible free use of certain articles and broadcast works and works seen or heard in connection with current events (Art 10*bis*), compulsory licenses for broadcasting and the like (Art 11*bis*), the Berne Convention (Art 10) states the following:

- It shall be permissible to make quotations from a work which has already been lawfully made available to the public, provided that their making is compatible with fair practice, and their extent does not exceed that justified by the purpose, including quotations from newspaper articles and periodicals in the form of press summaries.
- It shall be a matter for legislation in the countries of the Union, and for special agreements existing or to be concluded between them, to permit the utilization, to the extent justified by the purpose, of literary or artistic works by way of illustration in publications, broadcasts or sound or visual recordings for teaching, provided such utilization is compatible with fair practice.
- Where use is made of works in accordance with the preceding paragraphs of this Article, mention shall be made of the source, and of the name of the author if it appears thereon.

5. *Fair dealing:* The position of some jurisdictions is that it is for the legislature to prescribe what amounts to fair use and that the overriding conditions prescribed by Art 9.2 of the Berne Convention do not concern courts in deciding the issue in the ultimate event.

Typical of the common-law tradition is the Irish legislation. One provision only of the many will be quoted to illustrate the matter. The Act permits, for instance, fair dealing with a literary, dramatic, musical or artistic work, sound recording, film, broadcast, cable program, or non-electronic original database, for the purposes of research or private study.

“Fair dealing” is defined to mean the making use of a [work] which has already been lawfully made available to the public, “for a purpose and to an extent which will not unreasonably prejudice the interests of the owner of the copyright.”

6. *Made available to the public:* Fair dealing is only possible in relation to works that have been made available to the public in a lawful manner.¹⁸⁶

BELOFF v PRESSDAM LTD

[1973] 1 All ER 241 [UK]

The law by bestowing a right of copyright on an unpublished work bestows a right to prevent its being published at all; and even though an unpublished work is not automatically excluded from the defense of fair dealing, it is yet a much more substantial breach of copyright than publication of a published work.

7. *Assessing fair dealing in the common-law tradition:*¹⁸⁷

ASHDOWN v TELEGRAPH GROUP LTD

[2001] EWCA Civ 1142 [UK]

Authority is very sparse in relation to the defense of fair dealing in the context of reporting current events. The [court below] commented with approval, however, on the summary of Laddie, Prescott & Vitoria *The Modern Law of Copyright and Designs*, para 20.16, on the test of fair dealing in the general context of s 30. We also have found this an accurate and helpful summary and set it out for the purpose of discussion.

“It is impossible to lay down any hard-and-fast definition of what is fair dealing, for it is a matter of fact, degree and impression. However, by far the most important factor is whether the alleged fair dealing is in fact commercially competing with the proprietor’s exploitation of the copyright work, a substitute for the probable purchase of authorized copies, and the like. If it is, the fair dealing defense will almost certainly fail. If it is not and there is a moderate taking and there are no special adverse factors, the defense is likely to succeed, especially if the defendant’s additional purpose is to right a wrong, to ventilate an honest grievance, to engage in political controversy, and so on.

The second most important factor is whether the work has already been published or otherwise exposed to the public. If it has not, and especially if the material has been obtained by a breach of confidence or other mean or underhand dealing, the courts will be reluctant to say this is fair. However this is by no means conclusive, for sometimes it is necessary for the purposes of legitimate public controversy to make use of ‘leaked’ information.

187 See further *CCH Canadian Ltd v Law Society of Upper Canada* 2004 SCC 13 [Canada].

The third most important factor is the amount and importance of the work that has been taken. For, although it is permissible to take a substantial part of the work (if not, there could be no question of infringement in the first place), in some circumstances the taking of an excessive amount, or the taking of even a small amount if on a regular basis, would negative fair dealing.”

8. *Fair dealing is a matter of impression and fact:*

HUBBARD v VOSPER

[1972] 1 All ER 1023 (CA) [UK]

It is impossible to define what is “fair dealing”. It must be a question of degree. You must consider first the number and extent of the quotations and extracts. Are they altogether too many and too long to be fair? Then you must consider the use made of them. If they are used as a basis for comment, criticism or review, that may be a fair dealing. If they are used to convey the same information as the author, for a rival purpose, that may be unfair. Next, you must consider the proportions. To take long extracts and attach short comments may be unfair. But, short extracts and long comments may be fair. Other considerations may come to mind also. But, after all is said and done, it must be a matter of impression. As with fair comment in the law of libel, so with fair dealing in the law of copyright. The tribunal of fact must decide.

FRASER-WOODWARD LTD v BRITISH BROADCASTING CORPORATION BRIGHTER PICTURES LTD

[2005] EWHC 472 (Ch) [UK]

If use of copyright material is to fall within section 30(1) then that use must amount to “fair dealing”. In considering whether the use in the present case amounted to fair dealing (and the claimant says it was not) the following guidelines are relevant:

- It is relevant to have regard to the motives of the user (contrast the question of criticism and review where the focus is more on the actual use without, or without so much, reference to the motive).
- Whether there is fair dealing is a matter of impression.

“What amounts to fair dealing must depend on the facts of the particular case and must to a degree be a matter of impression. What is of prime importance is to consider the real objective of

the party using the copyright work. Section 30 is designed to protect a critic or reviewer who may bona fide wish to use the copyright material to illustrate his review or criticism.”

- If some degree of use would be fair dealing, excessive use can render the use unfair.
- In assessing whether the dealing is fair the court can have regard to the actual purpose of the work, and will be live to any pretense in the purported purpose of the work:

“It is necessary to have regard to the true purpose of the work. Is it a genuine piece of criticism or review, or is it something else, such as an attempt to dress up the infringement of another’s copyright in the guise of criticism, and so profit unfairly from another’s work?”

- In the same vein, the amount of the work used can be relevant:

“I may add, however, that the substantiality of the part reproduced is, in my view, an element which the Court will take into consideration in arriving at a conclusion whether what has been done is a fair dealing or not. To take an example, if a defendant published long and important extracts from a plaintiff’s work and added to those extracts some brief criticisms upon them, I think that the Court would be very ready to arrive at the conclusion that that was not fair dealing within the section.”

- However, this must be carefully applied in relation to photographs. It makes more sense in relation to extended literary or musical works. If one is critiquing a photograph, or using it for the purpose of criticizing another work, then the nature of the medium means that any reference is likely to be by means of an inclusion of most of the work because otherwise the reference will not make much sense. This degree of care is particularly appropriate in the context of a television program where the exposure is not as (for example) continuous or permanent as publication in printed form would be.
- Reproduction should not unreasonably prejudice the legitimate interests of the author or conflict with the author’s normal exploitation of the work – see the Berne Copyright Convention Article 9(2).

9. *Commercial exploitation is not fair dealing:*

NEWSPAPER LICENSING AGENCY LTD v MARKS & SPENCER PLC

[2000] EWCA Civ 179 [UK]¹⁸⁸

Fair dealing, as a concept, appears not only in section 30(2), but also in section 29 (fair dealing for the purposes of research or private study) and section 30(1) (fair dealing for the purpose of criticism or review). That is the context in which the phrase must be construed. When those provisions are read together, it seems to me that a dealing by a person with copyright work for his own commercial advantage – and to the actual or potential commercial disadvantage of the copyright owner – is not to be regarded as a ‘fair dealing’ unless there is some overriding element of public advantage which justifies the subordination of the rights of the copyright owner. In my view it was the recognition that the property right conferred on the copyright owner by the 1988 Act and its statutory predecessors – and which, subject to the provisions of the Act, the copyright owner is entitled to protect and exploit – should yield, in appropriate circumstances, to an overriding public interest in the promotion of research or private study, in the publication of comment or criticism, or in the reporting of current events which led Parliament to include the fair dealing provisions in the legislation.

I can see no reason why Parliament should have intended, in the absence of some overriding element of public advantage, to permit one person to deal with copyright work to his own commercial advantage and to the actual or potential commercial disadvantage of the copyright owner; and no reason why what would otherwise be an infringement of the rights of the owner of copyright in typographical arrangement should be permitted simply because the particular commercial advantage to be obtained was a more convenient (or less costly) means of disseminating reports of current events within a commercial organization by the circulation of facsimile copies of press cuttings.

10. *Fair use in US law:* US law is different because it uses the concept of fair use and sets out a list of purposes for which the reproduction of a particular work may be considered fair, such as criticism, comment, news reporting, teaching, scholarship, and research. It also sets out four factors that have to be considered in determining whether or not a particular use is fair: the purpose and character of the use, including whether such use is

188 The judgment was overruled on appeal, but on another point: [2001] UKHL 38.

of commercial nature or is for nonprofit educational purposes; the nature of the copyrighted work; the amount and substantiality of the portion used in relation to the copyrighted work as a whole; and the effect of the use upon the potential market for or value of the copyrighted work. It is thought by some that this approach is not in accordance with the Berne Convention.

TY INC v PUBLICATIONS INTERNATIONAL LTD

292 F.3d 512 [USA]

The defense of fair use, originally judge-made, now codified, plays an essential role in copyright law. Without it, any copying of copyrighted material would be a copyright infringement. A book reviewer could not quote from the book he was reviewing without a license from the publisher. Quite apart from the impairment of freedom of expression that would result from giving a copyright holder control over public criticism of his work, to deem such quotation an infringement would greatly reduce the credibility of book reviews, to the detriment of copyright owners as a group, though not to the owners of copyright on the worst books. Book reviews would no longer serve the reading public as a useful guide to which books to buy. Book reviews that quote from (“copy”) the books being reviewed increase the demand for copyrighted works; to deem such copying infringement would therefore be perverse, and so the fair-use doctrine permits such copying.

On the other hand, were a book reviewer to quote the entire book in his review, or so much of the book as to make the review a substitute for the book itself, he would be cutting into the publisher’s market, and the defense of fair use would fail. Generalizing from this example in economic terminology that has become orthodox in fair-use case law, we may say that copying that is complementary to the copyrighted work (in the sense that nails are complements of hammers) is fair use, but copying that is a substitute for the copyrighted work (in the sense that nails are substitutes for pegs or screws), or for derivative works from the copyrighted work is not fair use.

11. *The design defense:* It is recognized that since copyright protection may overlap with industrial design protection, the owner of a registered design may be overprotected if he were also entitled to rely on copyright. Another problem relates to copyright protection in relation to spare parts: is it fair to prevent competitors to make spare parts through the use of copyright laws?¹⁸⁹ Legislatures have approached these problems differently and it is not possible to give a generally applicable set of rules.¹⁹⁰

189 *British Leyland Motor Corp Ltd v Armstrong Patents Co Ltd* [1986] 1 All ER 850 [UK]; *Klep Valves (Pty) Ltd v Saunders Valve Co Ltd* 1987 (2) SA 1 (A) [South Africa].

190 Cf *Sansomite Corporation v Vijay Sales* [2000] FSR 463 (HC) [India]; *Lambretta Clothing Company Ltd v Teddy Smith (UK) Ltd* [2004] EWCA Civ 886.

PATENTS: GENERAL PRINCIPLES

CHAPTER XI

- A. LEGISLATIVE TEXTS (1)
- B. PATENTS AND INVENTIONS (2-5)
- C. THE RIGHTS CONFERRED BY A PATENT (6-11)
- D. TERRITORIALITY (12-15)
- E. TYPES OF PATENTS (16)
- F. PATENT LITIGATION (17-22)
- G. THE FORM OF THE SPECIFICATION (23-24)
- H. THE BODY OF THE SPECIFICATION (25)
- I. THE RELATIONSHIP BETWEEN THE BODY OF THE SPECIFICATION AND THE CLAIMS (26-28)
- J. WHAT IS INFRINGEMENT? (29)
- K. THE FUNCTION OF THE CLAIMS (30-32)
- L. THERE IS NO INFRINGEMENT OF THE EQUITY OF A PATENT (33)
- M. INTEGERS OF CLAIMS (34)
- N. EMBODIMENTS (35)
- O. EXPERIMENTAL USE (36)

A. LEGISLATIVE TEXTS

1. *TRIPS*: The TRIPS Agreement imposes obligations in relation to the protection of patents on the Member States of the WTO. It also introduced certain provisions of the Paris Convention by reference. Some of these will be referred to in the course of the discussion and will form its basis. As before, it will be assumed that the laws of the WTO Member States comply with these provisions. For purposes of illustration a few national laws will also be quoted.

B. PATENTS AND INVENTIONS

2. *Patents for inventions*: Although the term “patent” is often used as synonymous with “invention”, the terms are not synonyms. Patents are granted for inventions. A patent is the grant of exclusive rights by the state for an invention. In other words, an invention is the subject matter of a patent. For example, Thomas Edison found that an electric current passed through a tungsten filament in a vacuum produces light and he used that finding to develop a light bulb. This invention entitled him to the grant of a patent.

3. *Patentable subject matter*. In order to be patentable, an invention must have patentable subject matter. The requirement is spelt out in TRIPS (Art. 27), which provides that patents must be available for any inventions:

- whether products or processes,
- in all fields of technology,
- provided that they are
 - new,
 - involve an inventive step (are non-obvious), and
 - are capable of industrial application (or useful).

Patents must be available and patent rights enjoyable without discrimination as to:

- the place of invention,
- the field of technology, and
- whether products are imported or produced locally.

4. *Limitations*: Member countries may refuse by law the patenting of certain inventions necessary to protect *ordre public* or morality within their territory, including to protect human, animal or plant life or health or to avoid serious prejudice to the environment, provided that such exclusion is not made merely because the exploitation is prohibited by their law. They may, in addition, exclude from patentability:

- diagnostic, therapeutic and surgical methods for the treatment of humans or animals;
- plants and animals other than microorganisms, and
- essentially biological processes for the production of plants or animals other than non-biological and microbiological processes.

However, there is a duty to provide for the protection of plant varieties either by patents or by an effective *sui generis* system or a combination of them.¹⁹¹

The European Patent Convention (Art. 52), for instance, excludes the following classes from its definition of “invention”:

- discoveries, scientific theories and mathematical methods;
- aesthetic creations;
- schemes, rules and methods for performing mental acts, playing games or doing business,
- programs for computers;¹⁹² and
- presentations of information.

In this regard it differs significantly from the position in the USA where business methods and programs for computers are patentable.

5. Discoveries and inventions: A discovery (including the laws of nature, physical phenomena and abstract ideas) is not a patentable invention even where a statute provides that “whoever invents or discovers any new and useful process, machine, manufacture may obtain a patent therefore” as in the US. Marie Curie, for example, discovered the radio-active element radium, isolated it and established its properties. This discovery did not entitle her to a patent without any industrial application. The discovery of X-rays by Röntgen consisted of an application for medical use of the properties of radio-active material and was an invention that could have been patented.¹⁹³

The earliest known English patent for an invention was granted by King Henry VI to Flemish-born Jan (John) of Uytynam in 1449. The patent gave him a 20-year monopoly for a method of making stained glass, required for the windows of Eton College, something not previously known in England.

191 The International Convention for the Protection of New Varieties of Plants is administered by the International Union for the Protection of New Varieties of Plants (UPOV). This Case Book does not cover issues relating to protection of plant varieties.

192 The exact scope of this exclusion has been the subject of many decisions.

193 *Genentech Inc's Patent* [1989] RPC 147 (CA) [UK]; *Chiron Corp v Murex Diagnostics Ltd* [1997] RPC 535 (CA) [UK].

DIAMOND v CHAKRABARTY

(1980) 447 US 303, 100 S Ct 2204

The laws of nature, physical phenomena, and abstract ideas have been held not patentable. Thus, a new mineral discovered in the earth or a new plant found in the wild is not patentable subject matter. Likewise, Einstein could not patent his celebrated law that $E=mc^2$ nor could Newton have patented the law of gravity. Such discoveries are “manifestations of nature, free to all men and reserved exclusively to none.”

GENENTECH INC'S PATENT

[1987] RPC 553

It is trite law that you cannot patent a discovery, but if on the basis of that discovery you can tell people how it can be usefully employed, then a patentable invention may result. This in my view would be the case, even though once you have made the discovery, the way in which it can be usefully employed is obvious enough.

C. THE RIGHTS CONFERRED BY A PATENT

6. *The rationale for patent protection:*

FREE WORLD TRUST v ÉLECTRO SANTÉ INC

2000 SCC 66 [Canada]

Patent protection rests on the concept of a bargain between the inventor and the public. In return for disclosure of the invention to the public, the inventor acquires for a limited time the exclusive right to exploit it. It was ever thus. Even before the *Statute of Monopolies* (1623), the Crown rewarded an inventor with a limited monopoly in exchange for public disclosure of “a new invention and a new trade within the kingdom ... or if a man hath made a new discovery of any thing”: *Clothworkers of Ipswich Case* (1653), where the court went on to say that the effect of an unjustified monopoly was “to take away free-trade, which is the birthright of every subject”.

CFS BAKEL BV v STORK TITAN BV

AU6098, Hoge Raad (Supreme Court), C04/334HR [The Netherlands]

In assessing this legal complaint [the issue related to the liability in damages of a patentee who attempts to enforce a patent which proved to be invalid], which is essentially an invitation to reconsider

the prevalent doctrine in the Netherlands outlined below, the following two points of view should be considered.

On the one hand, the granting of a patent honors the achievement underlying the invention embodied in the patent, as well as the research carried out and the investment in time and money. This encourages the making of inventions, which also serves the public interest. These considerations argue in favor of not regarding the owner of a tested patent liable to his competitors on the grounds of an unlawful act solely on the ground that the patent has been subsequently revoked or declared void. The patent owner would otherwise be discouraged from exercising his rights against those who deny them to him, which might reduce the incentive to produce inventions.

On the other hand, the granting of a patent (or at least the invoking of it) restricts competition and gives the patentee a lead on the competition. The invoking of the patent against third parties is generally an appropriate means of influencing the behavior of those third parties to the patent owner's benefit. The fact that our social system is based precisely on the encouragement of free competition in the public interest is an argument, in this light, for allowing the person who relies on a patent that is subsequently revoked or declared void to bear the risk of his claims being disproved.

7. *The TRIPS requirements:* The exclusive rights conferred by a patent are (Art. 28 of TRIPS):

- where the subject matter of a patent is a product, to prevent third parties not having the owner's consent from the acts of: making, using, offering for sale, selling, or importing [this right, like all other rights conferred under this Agreement in respect of the use, sale, importation or other distribution of goods, is subject to the provisions of Article 6] for these purposes that product;
- where the subject matter of a patent is a process, to prevent third parties not having the owner's consent from the act of using the process, and from the acts of: using, offering for sale, selling, or importing for these purposes at least the product obtained directly by that process.

8. *Negative right:* It follows from the definition that a patent does not entitle the patentee to use the invention, but only to prevent others from using it. The exploitation of a later (dependent) patent, which is valid, may for instance infringe the earlier master patent (although the second

patentee may be able to obtain a compulsory cross-licence). Usually, though, a patentee will be able to exercise a patented invention and a failure to exercise the invention may lead to a compulsory licence.

PANDUIT CORP v STAHLIN BROS

575 F2d 1152 [USA]

Patents must by law be given “the attributes of personal property”. The right to exclude others is the essence of the human right called “property”. The right to exclude others from free use of an invention protected by a valid patent does not differ from the right to exclude others from free use of one’s automobile, crops, or other items of personal property. Every human right, including that in an invention, is subject to challenge under appropriate circumstances. That one human property right may be challenged by trespass, another by theft, and another by infringement, does not affect the fundamental *indicium* of all “property”, i.e., the right to exclude others.

9. *A patent does not create a monopoly*:¹⁹⁴

UNITED STATES v DUBILIER CONDENSER CORP

289 US 178 (1933) [USA]

Though often so characterized, a patent is not, accurately speaking, a monopoly, for it is not created by the executive authority at the expense and to the prejudice of all the community except the grantee of the patent. The term “monopoly” connotes the giving of an exclusive privilege for buying, selling, working or using a thing which the public freely enjoyed prior to the grant. Thus a monopoly takes something from the people. An inventor deprives the public of nothing which it enjoyed before his discovery, but gives something of value to the community by adding to the sum of human knowledge.

This statement is contentious and depends on one’s view of what a monopoly is in economic terms.¹⁹⁵

194 See also the quotation from *Panduit Corp v Stahlin Bros* supra in Chapter 1.

195 See e.g. Patricia Loughlan *Patents: Breaking into the Loop* (1998) 20 Sydney Law Review 553.

10. *A patentee is entitled to price its products:*

CANON INC. v RECYCLE ASSIST C, LTD

[2006] JPIPHC 3 [Japan]

Division Grand Panel:

Recycle Assist, criticizing Canon's business model (i.e. selling printers at a low price and driving the printer users to buy the genuine ink tanks at a high price, thereby making unfair profits), argues that Canon's exercise of the Patent would harm consumer interest and afford excessive protection to the patent holder.

However, there is no evidence that shows Canon's business model is as argued by Recycle Assist. In addition, as compensation for the disclosure of an industrially applicable invention to the public, the patent holder is given the exclusive right to exploit the patented invention for making profit, and the patent holder has discretion to set the prices of the patented products and other related products unless there are special circumstances where such pricing is against public interest or public order under the Anti-monopoly Law, etc. If it is assumed, as argued by Recycle Assist, that Canon sets the price of the genuine products at a level significantly higher than the manufacturing cost and gains excessive profits from the sale of the genuine products, it follows that Recycle Assist [by infringing] also gains excessive profits considering such factors as the price gap between the genuine products and the recycled products and costs incurred by Canon and Recycle Assist respectively (Recycle Assist incurs expenses for manufacturing and transporting the recycled products but has avoided R&D costs for the patented invention and manufacturing costs for the ink tank). Therefore, it is unreasonable for Recycle Assist to argue that Canon's exercise of the Patent rights should not be allowed for the benefit of consumers.

11. *The term of protection:* The minimum term of a patent is 20 years, and this is calculated as from the date of filing and not the date of grant. Article 33 of TRIPS is explicit in this regard:

The term of protection available shall not end before the expiration of a period of twenty years counted from the filing date. [The footnote reads: It is understood that those Members which do not have a system of original grant may provide that the term of protection shall be computed from the filing date in the system of original grant.]

Since patent rights are only granted (sometimes many) years after filing of the application for a patent, this means that the effective term of patent protection may be much shorter than 20 years. Another complicating factor is the fact that for certain products, such as pharmaceuticals, some or other regulatory permission is required before they may be marketed, and this can further reduce the effective term of protection. For this reason some countries used to provide for an extension of the term of a patent on the ground of inadequate remuneration and others, such as the European Union, have provision for supplementary protection certificates, which have the same effect.¹⁹⁶

D. TERRITORIALITY

12. *Territoriality*: Patents are territorial. This principle is spelt out by the Paris Convention (Art. 4*bis*), which provides:

Patents applied for in the various countries of the Union by nationals of countries of the Union shall be independent of patents obtained for the same invention in other countries, whether members of the Union or not.

The foregoing provision is to be understood in an unrestricted sense, in particular, in the sense that patents applied for during the period of priority are independent, both as regards the grounds for nullity and forfeiture, and as regards their normal duration.

13. *The effect of the principle*: In practical terms it means that an inventor in country A may apply for a patent in A and may, within the period of one year apply in country B for a patent in relation to the same invention. These two patents will exist independently. They may differ in scope. The one may lapse or be revoked without affecting the other. It also means that a patentee can only sue for patent infringement in a country where the invention is patented.¹⁹⁷ The principle is also relevant for judging the legality of parallel importation (the importation of so-called grey goods) and the doctrine of patent exhaustion.¹⁹⁸

KODAK AG v JUMBO MARKT AG

Swiss Federal Court (First Division):¹⁹⁹

196 Regulation (EC) No. 469/2009 concerning the supplementary protection certificate for medicinal products, *OJ*, 2009, L152/1.

197 See further the section on jurisdiction in chapter 1 part I.

198 See the chapter on Exhaustion below..

199 As reported in translation [2001] ENPR 11.

According to Bundesgericht [Federal Court] practice, the Swiss Patentgesetz [Patents Act] has a strictly territorial purview. This means, in particular, that the protection conferred by a Swiss patent ends at the Swiss border. The protection which the Swiss patent law endeavors to provide is valid only within Swiss national boundaries, and patent infringements are covered by it only if they have an effect in Switzerland, that is to say, if the products unlawfully made or used in imitation of the invention enter Swiss territory. This means, for example, that Switzerland cannot be considered as the place where the contract was made, irrespective of whether the products are intended solely for third countries. If they are, the scope of protection conferred by the law will then extend outside Switzerland. The manufacture of products outside Switzerland in infringement of a patent protected in Switzerland is also covered by the Swiss Patentgesetz only if the products are imported into Switzerland to be marketed in Switzerland or even just to be stored there before being re-exported. According to the territoriality principle, the unauthorized use of a patented invention is in breach of Swiss law only if it takes place inside Switzerland. This does not, however, mean that acts committed outside Switzerland are irrelevant in every case. On the contrary, it is sufficient for the unlawful use in Switzerland to have been instigated or actively encouraged from outside Switzerland. Furthermore, the party committing the act is responsible under Swiss law for any act or omission, irrespective of where this occurs, if such behavior is the material cause of a use in Switzerland.

The territoriality principle is also enshrined in international patent law. Under the international treaties to which Switzerland is party, patent protection is therefore always restricted to the States for which the rightful party is expressly claiming this protection and for which the appropriate formal requirements for protection are satisfied.

DEEPSOUTH PACKING CO v LAITRAM CORP

406 US 518 (1972) [USA]

The statute makes it clear that it is not an infringement to make or use a patented product outside of the United States. Thus, in order to secure the injunction it seeks, [the plaintiff] must show a direct infringement by [the defendant] in the United States, that is, that [the defendant] “makes”, “uses”, or “sells” the patented product within the bounds of this country.

The effect of this judgment on its particular facts was undone by way of an amendment to the US Patents Act but even that amendment has restricted application as appears from the following extract.

MICROSOFT CORP v AT&T CORP

550 US (2007) [USA]

Any doubt that Microsoft's conduct falls outside [the amendment] would be resolved by the presumption against extraterritoriality. The presumption that United States law governs domestically but does not rule the world applies with particular force in patent law. The traditional understanding that our patent law "operate[s] only domestically and d[oes] not extend to foreign activities," is embedded in the Patent Act itself, which provides that a patent confers exclusive rights in an invention within the United States.

As a principle of general application, moreover, we have stated that courts should "assume that legislators take account of the legitimate sovereign interests of other nations when they write American laws". Thus, the United States accurately conveyed in this case: "Foreign conduct is [generally] the domain of foreign law," and in the area here involved, in particular, foreign law "may embody different policy judgments about the relative rights of inventors, competitors, and the public in patented inventions."

14. *Jurisdiction under the Brussels Convention:*

GESELLSCHAFT FÜR ANTRIEBSTECHNIK MBH & CO. KG v LAMELLEN UND KUPPLUNGSBAU BETEILIGUNGS KG

ECJ, 13 July 2006, C-4/03, ECR 2006, I-6509

Thus, the exclusive jurisdiction in proceedings concerned with the registration or validity of patents conferred upon the courts of the Contracting State in which the deposit or registration has been applied for or made is justified by the fact that those courts are best placed to adjudicate upon cases in which the dispute itself concerns the validity of the patent or the existence of the deposit or registration. The courts of the Contracting State on whose territory the registers are kept may rule, applying their own national law, on the validity and effects of the patents which have been issued in that State. This concern for the sound administration of justice becomes all the more important in the field of patents since, given the specialized nature of this area, a number of Contracting States have set up a system of specific judicial protection, to ensure that these types of cases are dealt with by specialized courts.

That exclusive jurisdiction is also justified by the fact that the issue of patents necessitates the involvement of the national administrative authorities.

The argument that under German law the effects of a judgment indirectly ruling on the validity of a patent are limited to the parties to the proceedings is not an appropriate response to that risk. The effects flowing from such a decision are in fact determined by national law. In several Contracting States a decision to annul a patent has *erga omnes* effect. In order to avoid the risk of contradictory decisions, it is therefore necessary to limit the jurisdiction of the courts of a State other than that in which the patent is issued to rule indirectly on the validity of a foreign patent to only those cases in which, under the applicable national law, the effects of the decision to be given are limited to the parties to the proceedings. Such a limitation would, however, lead to distortions, thereby undermining the equality and uniformity of rights and obligations arising from the Convention for the Contracting States and the persons concerned.

15. *The independence of patents:*

BBS CASE

Japan Supreme Court
1 July 1997

Article 4*bis* of the Paris Convention denies the mutual dependency of patents, and stipulates that patents in the various countries of the Paris Union shall be independent of each other regarding their generations, variations and extinctions; that is, a patent in one country is independent from a patent in another country with respect to nullity, forfeiture and normal duration. A question of whether or not to allow a patentee to enforce his patent right under a certain condition is of no concern in Article 4*bis*.

The territoriality principle in patents means that a patent right in a country of the Paris Union shall be defined by that country's laws as regards its establishment, transfer, validity, among other things, and that the patent right can be enforced only in that country's territory. In the case where a Japanese patent owner enforces his/her Japanese patent right within Japan, it is entirely a matter of interpretation of the Japanese Patent Law as to how the fact that the accused products were already lawfully sold by the patent owner in a foreign country is considered for determining whether or not the

patent owner can indeed enforce his Japanese patent right on the accused products in Japan.

This matter is irrelevant with respect to the Paris Convention or the territoriality principle.

E. TYPES OF PATENTS

16. *Types of patents:* It follows from Art. 28 of TRIPS that patents are classified either as (a) product patents or (b) process (method) patents. Typically, the same patent may have claims for both types of inventions.

A process patent protects the patentee not only against the use of the process within the jurisdiction but also against importation of goods made elsewhere by the same process. The Paris Convention (Art. 5*quater*) provides as follows:

When a product is imported into a country of the Union where there exists a patent protecting a process of manufacture of the said product, the patentee shall have all the rights, with regard to the imported product, that are accorded to him by the legislation of the country of importation, on the basis of the process patent, with respect to products manufactured in that country.

In addition, as appears from TRIPS, the product produced by the process is also protected (but not if the product is produced by another process). Then there are inventions protected by what is known as Swiss claims.

ACTAVIS UK LTD V MERCK & CO INC

[2008] EWCA Civ 444

Swiss form claims have been long accepted in the UK. Such a claim steers clear of two obstacles to patentability, namely the requirement of novelty and the ban on methods of treatment of the human body by therapy. It follows a statement of practice regarding “use claims” issued by the Swiss Federal Intellectual Property Office. The generalized form of such a claim is “the use of compound X in the manufacture of a medicament for a specified (and new) therapeutic use”. Such claims are unnecessary when X is new, for then X can be patented in itself. But when X is old, a Swiss form of claim confers novelty and yet is not a claim to a method of treatment.

The Enlarged Board of the European Patent Office so held in *Eisai*, G5/83 [1985] OJ EPO 64. It said:

“It is legitimate in principle to allow claims directed to the use of a substance or composition for the manufacture of a medicament for a specified new and inventive therapeutic application, even in a case where the process of manufacture as such does not differ from known processes using the same active ingredient.”

So the manufacture of an old substance for use in a new treatment was considered by the Enlarged Board to be novel. The justification for novelty was the new therapeutic use. And since the claim was to the manufacture of the compound, it was not a claim to a method of treatment.

F. PATENT LITIGATION

17. *Special or general courts:* Patent infringement is a statutory wrong (tort or delict). The jurisdiction to try infringement cases is sometimes granted to special patent tribunals to the exclusion of other courts and sometimes to the ordinary courts of the land. Patent appeals are, however, generally dealt with by the ordinary appellate courts in the common-law world (the USA is a notable exception) but there are also specialist patent appeal courts in some civil-law countries.

18. *The plaintiff:* An infringement action may be instituted by the registered patentee (who may not be the inventor since the patent rights may be assigned); or by a licensee of right (but only after having called upon the patentee to do so, in which event the patentee must be joined as a defendant). This, and what follows in this section, contains generalizations which depend on the terms of each Patents Act.

19. *Intervention as plaintiff:* Notice of the intended litigation must be given by the patentee to every licensee under the patent whose name is recorded in the register; this enables any such licensee to join as co-plaintiff as of right and to recover any damages suffered as a result of the infringement. Likewise, a joint patentee who institutes infringement proceedings must give notice to every other joint patentee, who may intervene as co-plaintiff and recover its own loss.

20. *The grant:* The plaintiff must allege and prove that the patent has been granted (not merely applied for) and that it was at all relevant times

in existence. It is practice, though unnecessary, to allege that the patent is valid. There generally is a presumption that a registered patent is valid.²⁰⁰ A patent is a public document and may be proved by means of a certificate signed by the registrar of patents or the like.

21. Acts of infringement: The plaintiff must allege and prove that the defendant has infringed one or more of the claims of the patent. The practice in this regard is to plead one or more particular instances of infringement which will be the subject of the evidence. If the act is established, an inquiry into damages will follow and during this process the extent of the infringement will be litigated.

22. Invalidity: A defendant may rely on the invalidity of a patent in two ways: in the plea, as a defense; and (optionally) in a counterclaim for the revocation of the patent. There is little, if any, merit in not counterclaiming for revocation.

In some countries the jurisdiction to try an infringement case is different from the jurisdiction to try a case of invalidity. The effect of this is that the infringement case may have to be suspended pending the finalization of the revocation proceedings in the other court.

The grounds of invalidity are usually enumerated in the statute and are limited in number. The onus rests on the defendant to allege and prove the invalidity of the patent and each particular statutory ground of invalidity relied on must be pleaded separately and distinctly and considered separately by the court. Although each objection must be considered separately, evidence on one aspect may be relevant to another.

The attack of invalidity must, as far as possible, be directed towards the claims relied on by the plaintiff, because some relief may be granted in respect of a partially valid patent in some jurisdictions.²⁰¹

GESELLSCHAFT FÜR ANTRIEBSTECHNIK MBH & CO. KG v LAMELLEN UND KUPPLUNGSBAU BETEILIGUNGS KG

ECJ, 13 July 2006, C-4/03, ECR 2006, I-6509

In practice, however, the issue of a patent's validity is frequently raised as a plea in objection in an infringement action, the defendant seeking to have the claimant retroactively denied the right on which the claimant relies and thus have the action brought against him

200 In India, though, there is a specific provision in the Act to the effect that there is no such presumption: *Standipack Pty Ltd v Oswal Trading Co* 1999 PTC (19) 479.

201 *Auspflow (Pty) Ltd v Northpark Trading 3 (Pty) Ltd and Others* [2011] ZASCA 123.

dismissed. The issue can also be invoked, as in the case in the main proceedings, in support of a declaratory action seeking to establish that there has been no infringement, whereby the claimant seeks to establish that the defendant has no enforceable right in regard to the invention in question.

The civil onus is usually applied but the USA uses a higher standard.

MICROSOFT CORP. v. I4I LIMITED PARTNERSHIP

564 US (2011)

In asserting an invalidity defense, an alleged infringer must contend with the first paragraph of §282, which provides that “[a] patent shall be presumed valid” and “[t]he burden of establishing invalidity rest[s] on the party asserting such invalidity.” Under the Federal Circuit’s reading of §282, a defendant seeking to overcome this presumption must persuade the fact-finder of its invalidity defense by clear and convincing evidence.

The common-law presumption reflected the universal understanding that a preponderance standard of proof was too “dubious” a basis to deem a patent invalid. (“[A] patent is presumed to be valid until the presumption has been overcome by convincing evidence of error”). Thus, by the time Congress enacted §282 and declared that a patent is “presumed valid,” the presumption of patent validity had long been a fixture of the common law. According to its settled meaning, a defendant raising an invalidity defense bore “a heavy burden of persuasion,” requiring proof of the defense by clear and convincing evidence. That is, the presumption encompassed not only an allocation of the burden of proof but also an imposition of a heightened standard of proof.

G. THE FORM OF THE SPECIFICATION

23. *Contents:* A typical patent specification must contain the following:

- The name of the inventor (according to the Paris Convention an inventor is entitled to be named).
- A title.
- The body of the specification.
- Claims.

The Canadian Patent Act (s 27) is an example of a statute that deals fully with the requirements of a specification.²⁰² It requires that the specification of an invention must:

- correctly and fully describe the invention and its operation or use as contemplated by the inventor;
- set out clearly the various steps in a process, or the method of constructing, making, compounding or using a machine, manufacture or composition of matter, in such full, clear, concise and exact terms as to enable any person skilled in the art or science to which it pertains, or with which it is most closely connected, to make, construct, compound or use it;
- in the case of a machine, explain the principle of the machine and the best mode in which the inventor has contemplated the application of that principle;
- in the case of a process, explain the necessary sequence, if any, of the various steps, so as to distinguish the invention from other inventions; and
- must end with a claim or claims defining distinctly and in explicit terms the subject matter of the invention for which an exclusive privilege or property is claimed.

24. *Patent grant:* The patent grant will contain additionally the date of the application and the date of grant and will reflect whether or not priority in terms of the Paris Convention is claimed (i.e., whether the application is based on the filing in a convention country).

H. THE BODY OF THE SPECIFICATION

25. *Sufficient description:* As appears from the quoted Canadian provision, the specification must sufficiently describe, ascertain and, where necessary, illustrate or exemplify the invention and the manner in which it is to be performed in order to enable the invention to be performed by a person skilled in the art of such invention.

Apart from a description of the invention, the specification usually consists of a general description of the state of the prior art and the problem that faced the inventor, and explains the inventive step. It may contain examples and drawings.

²⁰² The Canadian Supreme Court was not happy with the formulation of the provision, finding that it is not clear or concise: *Consolboard Inc v Macmillan Bloedel* [1981] 1 SCR 504.

Some laws require an abstract but provide that the abstract may not be used in interpreting the specification. The specification may also contain a so-called consistory clause, a paragraph or section which sets out the heart of the invention. Quite often it is a recital of the first or broadest claim and is inserted to avoid an attack of lack of fair basis or insufficiency.

I. THE RELATIONSHIP BETWEEN THE BODY OF THE SPECIFICATION AND THE CLAIMS

26. *The claims do not form a separate document:*

ELECTRIC AND MUSICAL INDUSTRIES LTD v LISSEN LTD

(1938) 56 RPC 23 [UK]

The function of the claims is to define clearly and with precision the monopoly claimed, so that others may know the exact boundary of the area within which they will be trespassers. Their primary object is to limit and not to extend the monopoly. What is not claimed is disclaimed. The claims must undoubtedly be read as part of the entire document and not as a separate document; but the forbidden field must be found in the language of the claims and not elsewhere.

27. *What is not claimed is disclaimed.*

FELLOWS v THOMAS WILLIAM LENCH

(1917) 34 RPC 45 [UK]

A claiming clause operates as a disclaimer of what is not specifically claimed, and for such disclaimer there may be reasons known to the inventor but not to the court.

MARCONI'S WIRELESS TELEGRAPH v PHILLIPS LAMPS LTD

1933 RPC 287

It is not sufficient for the inventor to discover his gold mine – he must also peg out his claim. Outside the pegs, the gold, if it is there, is free to all.

SARTAS NO. 1

30 IPR 486 [Australia]

In reading the specification as a whole the different functions of the claim and the rest of the specification should be observed. The claim, cast in precise language, marks out the legal limits of the monopoly

granted by the patent: and 'what is not claimed is disclaimed'. The specification describes how to carry out the process claimed and the best method known to the patentee of doing that.²⁰³

RA-LIPASE CASE

Supreme Court of Japan
8 March 1991

The summary of the invention in the patent application must be evaluated when examining whether the patent requirements of novelty and inventive step have been met as prerequisites. This determination, except for in cases of special circumstances, must be made on the basis of the scope of the patent claim as indicated in specifications attached to the patent application.

Only where the technological meaning contained in the scope of the patent claim cannot be clearly or unequivocally understood, or, where in light of the detailed description of the invention, there is an obvious error in the entry of the scope of the patent claim, among other cases, can the detailed explanation in the Specification be taken into account. This is evident from [the] Patent Law, which stipulates that in the scope of the patent claim only matters that are essential to the constitution of the invention in the patent applications shall be entered.

28. *Each part of the specification has a separate function:*

WELCH PERRIN CO PTY LTD v WORREL

[1960] HCA 91 [Australia]

The specification must be read as a whole. But it is a whole made up of several parts, and those parts have different functions. Courts have often insisted that it is not legitimate to narrow or expand the boundaries of monopoly as fixed by the words of a claim by adding to those words glosses drawn from other parts of the specification.

²⁰³ Quoted in *Leonardis v Theta Developments* [2000] SASC 402 [Australia].

J. WHAT IS INFRINGEMENT?

29. *Infringement is not necessarily defined by statute:*

LEONARDIS v THETA DEVELOPMENTS

[2000] SASC 402 [Australia]

The [Australian] Patents Act 1990 contains no definition of infringement. In terms of s 13 (and subject to the Act) a patent confers upon the patentee the exclusive rights during the term of the patent to exploit and to authorize another person to exploit the invention within the patent area (relevantly Australia). It may be concluded that infringement occurs when a person does an act which breaches the monopoly of the patentee.

The same applies, for example, to the South African Patents Act (s 45(1)):

The effect of a patent shall be to grant to the patentee in the Republic, subject to the provisions of this Act, for the duration of the patent, the right to exclude other persons from making, using, exercising, disposing or offering to dispose of, or importing the invention, so that he or she shall have and enjoy the whole profit and advantage accruing by reason of the invention.

The term “invention” in this provision means the invention claimed and not the broader invention as described or the inventive idea.

K. THE FUNCTION OF THE CLAIMS

30. *The claims define the exclusive right:* Infringement, consequently, involves the taking of the invention as claimed in the claims. The claims circumscribe the monopoly and amount to a definition of the invention for purposes of setting the limits of the monopoly.²⁰⁴

CUTTER I

BGH, judgment of March 12, 2002 – X ZR 168/00 [Germany]

According to article 14 of the Patents Act and the identical provision of Article 69, paragraph 1 of the European Patent Convention (EPC),

204 The UK the Patents Act defines the extent of “the invention” (s 125(1)) by stating: “For the purpose of this Act an invention for a patent ... shall, unless the context otherwise requires, be taken to be that specified in a claim as interpreted by the description and any drawings contained in that specification, and the extent of the protection conferred by a patent or application for a patent shall be determined accordingly.”

the extent of the protection conferred by a patent is determined by the terms of the claims and by the description and drawings used to interpret those claims. According to the relevant guidelines drawn up by the adjudicating Senate, the construction of the patent claims serves not only to clarify any ambiguities but also to explain the technical terms used therein and to clarify the meaning and scope of the invention described therein.

The description should be geared to consider the point of view of a person skilled in the art: it is on his/her understanding that the meaning of the contents of the patent claims – including the terms used therein – depends, and his/her understanding that is decisive in determining from their wording how far the scope of the protection conferred by the patent claims extends. In assessing whether use is being made of the invention protected under the patent, the contents of the patent claims must first be established, on the basis of the specialist's understanding – that is to say, the meaning inferred by the specialist from the wording of the claims.

31. *Fences and boundaries:*

FREE WORLD TRUST v ÉLECTRO SANTÉ INC

2000 SCC 66 [Canada]

Patent claims are frequently analogized to 'fences' and 'boundaries', giving the 'fields' of the monopoly a comfortable pretence of bright line demarcation. Thus, in *Minerals Separation North American Corp v Noranda Mines Ltd* [1947] Ex CR 306 Thorson P put the matter as follows:

“By his claims the inventor puts fences around the fields of his monopoly and warns the public against trespassing on his property. His fences must be clearly placed in order to give the necessary warning and he must not fence in any property that is not his own. The terms of a claim must be free from avoidable ambiguity or obscurity and must not be flexible; they must be clear and precise so that the public will be able to know not only where it must not trespass but also where it may safely go.”

In reality, the “fences” often consist of complex layers of definitions of different elements (or “components” or “features” or “integers”) of differing complexity, substitutability and ingenuity. A matrix of descriptive words and phrases defines the monopoly, warns the

public and ensnares the infringer. In some instances, the precise elements of the “fence” may be crucial or “essential” to the working of the invention as claimed; in others the inventor may contemplate, and the reader skilled in the art appreciate, that variants could easily be used or substituted without making any material difference to the working of the invention. The interpretative task of the court in claims construction is to separate the one from the other, to distinguish the essential from the inessential, and to give to the “field” framed by the former the legal protection to which the holder of a valid patent is entitled.

32. *All the essential integers must be taken before there can be an infringement of the claim:*

AZUKO PTY LTD v OLD DIGGER PTY LTD

[2001] FCA 1079 [Australia]

Infringement requires that all integers of the claim be taken, with the exception of the substitution of a mechanical equivalent of an inessential integer. *Populin v HB Nominees* (1982) 41 ALR 471 [held] that –

“the patentee must show that the defendant has taken each and every one of the essential integers of the patentee’s claim. Therefore if, on its true construction, the claim in a patent claims a particular combination of integers and the alleged infringer of it omits one of them he will escape liability.”

L. THERE IS NO INFRINGEMENT OF THE EQUITY OF A PATENT

33. *Mere similarities do not establish infringement:*

RAUBENHEIMER v KREEPY KRAULY (PTY) LTD

1987 (2) SA 650 (A) [South Africa]

From this description it is apparent that the Kreepy Krauly [the allegedly infringing device] achieves the same result as the patented device. The evidence shows moreover that the fundamental hydraulic operation, which enables the Kreepy Krauly to move over the surface to be cleaned, is the same as that in the patented device, namely the intermittent substantial variation of the flow of water through the machine. Such similarities have, of course, no bearing on the issue of infringement.

RODI AND WIENENBERGER AG v HENRY SHOWELL LTD

[1966] RPC 441 (CA) [UK]

In construing a modern specification, to speak of looking for the “substance” or the “pith and marrow” of the invention may lead one erroneously to suppose that the patentee, whatever be the precise language in which he has framed his claim, is entitled to a monopoly of the mechanical or other principle of which his invention makes use of or the result which his invention achieves. This is not so. If the language which the patentee has used in the claims which follow the description upon its true construction specifies a number of elements or integers acting in a particular relation to one another as constituting the essential features of his claim, the monopoly which he obtains is for that specified combination of elements or integers so acting in relation to one another – and for nothing else. There is no infringement of his monopoly unless each and every one of such elements is present in the process or article which is alleged to infringe his patent and such elements also act in relation to one another in the manner claimed.

M. INTEGERS OF CLAIMS

34. *The purpose of integers:* For the sake of convenience, a claim is divided into its elements (or, in patent jargon, its integers) for purposes of interpretation. It simplifies the exercise. But a claim need not have more than one element, for instance, a claim to a particular chemical compound consists of a single element.

A claim for a new toothpaste may have more than one integer and may read thus:

A dentifrice comprising a polishing agent, a water-soluble fluoride-containing compound which yields fluoride ions in aqueous solution, a buffering agent, the dentifrice being such that its pH is from 5 to 6.

This claim may be divided into the following integers: (a) A dentifrice comprising (b) a polishing agent, (c) a water-soluble fluoride-containing compound which yields fluoride ions in aqueous solution, (d) a buffering agent, (e) the dentifrice being such that its pH is from 5 to 6. In order to infringe, each of these integers must be present in the defendant's product.

N. EMBODIMENTS

35. Embodiments are discrete inventions: This claim for a toothpaste contains more than one embodiment (or discrete invention). For instance, the use of any polishing agent is claimed in this combination, whether talcum, gel or whatever. Therefore, a dentifrice with talcum and one with gel can be said to be discrete inventions falling within the scope of the claim (provided the other integers are present). Sometimes a claim may cover hundreds of thousand embodiments, particularly when a general chemical formula is used to describe a class of compounds.

O. EXPERIMENTAL USE

36. The Bolar exception: It has become the norm to allow some experimental use of patents by third parties without the consent of the patentee. One of these is to permit someone to prepare a dossier for the registration of a drug before the expiry of the patent. This is known as the Bolar exception after the US case of *Roche Pharmaceuticals v Bolar*²⁰⁵ and the subsequent legislative measures.

The Canadian provision is to the effect that it is not an infringement of a patent for any person to make, construct, use or sell the patented invention solely for uses reasonably related to the development and submission of information required under a law that regulates the manufacture, construction, use or sale of any product.

In Spain the exemption provision is wider because the rights conferred by a patent do not extend to practices engaged in for test purposes relating to the subject matter of a patented invention, in particular studies and trials conducted with a view to the authorization of generic medicinal products, within or outside of Spain, and the ensuing practical requirements, including preparing, obtaining and using the active principle for these purposes. Japan is not dissimilar and one may use a patented product as a building block for one's own innovation as long as the resulting discovery is not marketed until the patent expires.

205 *Roche Products v. Bolar Pharmaceutical*, 733 F.2d 858 (Fed. Cir. 1984). Some countries do not regard the Bolar exception under the experimental use exception.

PATENTS: INTERPRETATION

CHAPTER XII

- A. INTERPRETATION AND INFRINGEMENT (1-2)
- B. THE PROBLEM AREAS (3-5)
- C. STUDIED MISINTERPRETATION (6)
- D. THE PRIMARY RULES OF CONSTRUCTION (7-10)
- E. THE DOCTRINE OF EQUIVALENTS (11-16)
- F. PURPOSIVE CONSTRUCTION (17-21)
- G. THE EUROPEAN PATENT CONVENTION (EPC) (22-24)
- H. THE PROTOCOL QUESTIONS (25-28)
- I. ENGLISH LAW ON INTERPRETATION: THE FINAL WORD? (29)
- J. GERMAN LAW ON INTERPRETATION (30)
- K. JAPANESE LAW ON EQUIVALENTS (31-32)
- L. US LAW ON EQUIVALENTS (33-35)

A. INTERPRETATION AND INFRINGEMENT

1. *The need for interpretation:* In order to determine the scope of the claims, it is necessary to interpret them. Interpretation is a complicated process.

FABIO PERINI SPA v LPC GROUP PLC & ORS

[2010] EWCA Civ 525

The process of construction has to start somewhere, and when the ultimate issue is the interpretation of a common English word, it is often helpful to begin with its ordinary meaning before one turns to its documentary context and other relevant factors. After all, issues of interpretation (whether arising in connection with patents or any other commercial documents) often require an intracranial iterative process, involving multiple factors, including natural meaning, documentary context, technical considerations, commercial context, and business common sense.

Interpretation takes place without any regard to the infringing product or process. A patent has one meaning only, irrespective of whether validity or infringement has to be determined.²⁰⁶

WHIRLPOOL CORP v CAMCO INC

2000 SCC 67 [Canada]

A patent must not of course be construed with an eye on the allegedly infringing device in respect of infringement or with an eye to the prior art in respect of validity to avoid its effect. Claims construction cannot be allowed to become a results-oriented interpretation.

However, the defendant's alleged or admitted actions may limit the scope of the inquiry.

SELERO (PTY) LTD v CHAUVIER

1984 (1) SA 128 (A) [South Africa]

I appreciate that a patent specification should be construed without reference to what the alleged infringer has done. It is nevertheless convenient at this stage to focus attention on the infringing article in order to delimit and define the areas of dispute between the parties in regard to the issue of infringement.

206 Compare BGH, Judgment of June 29, 2010, *Crimpwerkzeug III* Case X ZR 193/03 [Germany].

2. *Incorrect comparison*: The comparison is not between the plaintiff's commercial product or process and that of the defendant. The plaintiff's claim is the only measure for comparison.

STAUFFER CHEMICAL CO v SAFSAN

1987 (2) SA 331(A)

At the outset I would point out that the comparison between the STC [the plaintiff's commercial product] and Genep Plus [the allegedly infringing product], which is central to appellant's argument, is a misconceived approach. Apart from the fact that the STC was not even a described embodiment of the invention, the correct comparison in law is between claim 1, properly construed, and Genep Plus. For the determination of the question as to whether or not the plaintiff has proved an infringement of his patent turns upon a comparison between the article or process, or both, involved in the alleged infringement and the words of the claims in the patent.

B. THE PROBLEM AREAS

3. *Problems with interpretation*. Reverting to the hypothetical claim mentioned before, namely:

A dentifrice comprising a polishing agent, a water-soluble fluoride-containing compound which yields fluoride ions in aqueous solution, a buffering agent, the dentifrice being such that its pH is from 5 to 6 .

Three problems arise typically with its interpretation.

- The first is purely one of meaning. A dispute may, for instance, arise in relation to the meaning of the term "polishing agent" and whether the defendant's product contains a polishing agent within the meaning of the term as used in the claim.
 - The second relates to equivalents. The defendant may use a chemical, which is the equivalent of fluoride, and the question will then be whether the claim is limited to fluoride or extends to its equivalents.
 - The third problem, which is related to the second, deals with the breadth of the claim: Would a pH of 4,9 fall within the scope of the claim?
4. *Pith and marrow*: It is in regard to the last two examples that it is necessary to determine whether any integer is essential or inessential and

why the concepts of pith and marrow and purposive construction have developed in the UK (see below, under E. The Doctrine of Equivalents). Courts have always frowned on immaterial alterations or omissions. The next citations (which contain some unjustified hyperbole) set the background to the problem.

WENHAM GAS COMPANY LTD v THE CHAMPION GAS LAMP COMPANY

(1891) 9 RPC 49 [UK]

The super-adding of ingenuity to a robbery does not make the operation justifiable. The fact that that new lamp, which is the result of having taken the invention of another person, is an improvement upon that other person's idea does not excuse the person who borrows what is not his.

INCANDESCENT GAS LIGHT CO v DE MARE etc SYSTEM

13 RPC 301 [UK]

When, however, you come to make that comparison, how can you escape from considering the relative magnitude and value of the things taken and of those left or varied; it is seldom that the infringer does the thing, the whole thing, and nothing but the thing claimed by the specification. He always varies, adds, omits and the only protection the patentee has in such a case lies, as has often been pointed out by every Court, from the House of Lords downward, in the good sense of the tribunal which has to decide whether the substance of the invention has been pirated.

IMPROVER CORPORATION v RAYMOND INDUSTRIAL LTD

[1990] HKCA 253 [Hong Kong]

It is a well-known rule of patent law that no one who borrows the substance of a patented invention can escape the consequences of infringement by making immaterial variations. The question is whether the infringing apparatus is substantially the same as the apparatus said to be infringed. It is also clear that there will be infringement of a patent even if the infringement is an improvement. If an inventor takes an essential integer of somebody else's patent and simply makes it work better by some alteration but does not change the way in which that integer basically operates, he can patent his own invention but it is what has been referred to by [counsel] as a "nesting" patent and if his device is produced and sold he must pay royalties to the other patentee. The alleged infringing patent can perform the same task but it

must, in at least one essential respect, do it in a different way if it is to escape liability.

5. *There is nothing special about the interpretation of patent specifications:* Much forensic skill and judicial ingenuity and time has been spent on the issue of interpretation. But once it is remembered that a patent does not differ materially from any other document also when it comes to interpretation, the matter is not that difficult. Before turning to that subject in more detail, it is necessary to set out the ordinary rules of interpretation.

C. STUDIED MISINTERPRETATION

6. *Forced interpretation:* Litigants tend to use a forced method of interpretation. Justice Oliver Wendell Holmes Jr once wrote in a letter to Harold Laski that

ideas rarely are difficult to grasp. The difficulties come from the language. To this day I am troubled as I hear arguments in patents cases, by the slang of the specialty. The thoughts behind the words rarely require a colossus.²⁰⁷

TOPLIFF v TOPLIFF

145 U.S. 156, 171 (1892)

The object of the patent law is to secure inventors what they have actually invented or discovered, and it ought not to be defeated by a too strict and technical adherence to the letter of the statute or by the application of artificial rules of interpretation.

WHITE v DUNBAR

119 US 47 (1886) [USA]

Some persons seem to suppose that a claim in a patent is like a nose of wax which may be turned and twisted in any direction, by merely referring to the specification, so as to make it include something more than, or something different from, what its words express. The claim is a statutory requirement, prescribed for the very purpose of making the patentee define precisely what his invention is; and it is unjust to the public, as well as an evasion of the law, to construe it in a manner different from the plain import of its terms.

MONSANTO CO v MDB ANIMAL HEALTH (PTY) LTD

[2001] ZASCA 4 [South Africa]

In patent litigation an application of Murphy's Law has special significance: if a word or sentence is capable of two interpretations, the reader will choose the wrong one. In this case the issue is whether alpha tocopherol acetate, a synthetic Vitamin E, is an 'oil' within the meaning of the term as used in the patent in suit. If it is, the respondent is infringing the patent. In spite of the narrow point of interpretation the parties were nevertheless able to generate a record of nearly 1300 pages.

***YKK CORPORATION v OPTI PATENT, FORSCHUNGS UND FABRIKATIONS AG
BOARDS OF APPEAL OF THE EUROPEAN PATENT OFFICE***

Case no T 0190/99 - 3.2.4

The board adds that the skilled person when considering a claim should rule out interpretations which are illogical or which do not make technical sense. He should try, with synthetical propensity i.e. building up rather than tearing down, to arrive at an interpretation of the claim which is technically sensible and takes into account the whole disclosure of the patent (Article 69 EPC). The patent must be construed by a mind willing to understand not a mind desirous of misunderstanding.²⁰⁸

CLEVELAND GRAPHITE BRONZE CO v GLACIER METAL CO LTD

(1949) RPC 157 (CA) [UK]

The vice of the respondents' contention appears to me to lie in the fact that for the purpose of having recourse to the legitimate use of the body of the specification as a dictionary they have seized upon a definition therein contained and read it out of its context. It is not right to seize upon one passage in the body of the specification and treat it as though it were an interpretation section in an Act of Parliament. In order to make proper use of the body of a specification for dictionary purposes the whole document must be considered: and even where a passage describes itself as a definition it must be read in its context.

²⁰⁸ The statement that a patent 'must be read by a mind willing to understand, not by a mind desirous of misunderstanding' must have been taken from *Lister v. Norton Brothers and Co.* (1886) 3 RPC199 (Ch D) per Chitty J.

D. THE PRIMARY RULES OF CONSTRUCTION

7. *The primary rules of interpretation:* These have often been formulated and reformulated. Here is a random sample.²⁰⁹

FREE WORLD TRUST v ÉLECTRO SANTÉ INC

2000 SCC 66 [Canada]

The appeal thus raises the fundamental issue of how best to resolve the tension between ‘literal infringement’ and ‘substantive infringement’ to achieve a fair and predictable result. There has been considerable discussion of this issue in Canada and elsewhere, which I will discuss briefly in support of the following propositions:

The *Patent Act* promotes adherence to the language of the claims. Adherence to the language of the claims in turn promotes both fairness and predictability.

- The claim language must, however, be read in an informed and purposive way.
- The language of the claims thus construed defines the monopoly. There is no recourse to such vague notions as the spirit of the invention to expand it further.
- The claims language will, on a purposive construction, show that some elements of the claimed invention are essential while others are non-essential. The identification of elements as essential or non-essential is made:
 - on the basis of the common knowledge of the worker skilled in the art to which the patent relates;
 - of the date the patent is published;
 - having regard to whether or not it was obvious to the skilled reader at the time the patent was published that a variant of a particular element would not make a difference to the way in which the invention works; or
 - according to the intent of the inventor, expressed or inferred from the claims, that a particular element is essential irrespective of its practical effect;
 - without, however, resort to extrinsic evidence of the inventor’s intention.
- There is no infringement if an essential element is different or omitted. There may still be infringement, however, if non-essential elements are substituted:

209 See also *Ranbaxy Australia Pty Ltd v Warner-Lambert Company LLC (No 2)* [2006] FCA 1787; *Monsanto Co v MDB Animal Health (Pty) Ltd* [2001] ZASCA 4 [South Africa].

8. *Dictionary meanings are not decisive:*

DE BEERS INDUSTRIAL DIAMOND DIVISION (PTY) LTD v ISHIZUKA

1980 (2) SA 191 (T) [South Africa]

A dictionary meaning of a word cannot govern the interpretation. It can only afford a guide. And, where a word has more than one meaning, the dictionary does not, indeed it cannot, prescribe priorities of meaning. The question is: what is the meaning applicable in the context of the particular document under consideration.

FUNDSTRUST (PTY) LTD (IN LIQ) v VAN DEVENTER

1997 (1) SA 710 (A) [South Africa]

Recourse to authoritative dictionaries is, of course, a permissible and often helpful method available to the courts to ascertain the ordinary meaning of words. But judicial interpretation cannot be undertaken by “excessive peering at the language to be interpreted without sufficient attention to the contextual scene”. The task of the interpreter is, after all, to ascertain the meaning of a word or expression in the particular context of the statute [or patent] in which it appears. As a rule every word or expression must be given its ordinary meaning and in this regard lexical research is useful and at times indispensable. Occasionally, however, it is not.

GLAXOSMITHKLINE INC v CANADA (ATTORNEY GENERAL)

2004 FC 1725 [Canada]

A dictionary approach is not to be used in construing claims. This would be using evidence from outside the four corners of the specification. Furthermore, looking at the claims of a patent using a dictionary approach is equivalent to looking at the words through the eyes of a grammarian or etymologist, rather than through the eyes of and with the knowledge of a person skilled in the art.

[The judgment contains a useful annexure setting out rules of construction.]

9. *The document must be interpreted as at the date of filing.*

SAPPI FINE PAPERS (PTY) LTD v ICI CANADA INC

1992 (3) SA 306 (A) [South Africa]

Consequently, a patent specification must be construed with reference to the state of knowledge of those skilled in the art; and,

according to English authority, the relevant state of knowledge is that obtaining at the time of the publication of the specification. I take this to be the time of filing of the application. This appears to be in accordance with our law.

10. *Interpretation is for the court and expert evidence has a limited role in relation to patent interpretation:* Interpretation is not a jury question. This means that it is not a factual issue but a legal one. As the German Federal Court said, the granted patent claim and its subject matter have a normative character and their meaning must therefore be determined as a question of law.²¹⁰

PFIZER CANADA INC v CANADA (MINISTER OF HEALTH)

2005 FC 1725 [Canada]

The Court construes the claim. It is not the function of an expert witness to construe the claim. As the [Canadian] Supreme Court said:

“The role of the expert was not to interpret the patent claims but to put the trial judge in the position of being able to do so in a knowledgeable way.”

The Court may be assisted by expert witnesses in order to understand the context of the invention described and the particular meaning of terms used in the patent. The expert, however, is not to displace the Court in the role of the person who is to interpret the claims. In *Whirlpool* the Supreme Court stated:

“The key to purposive construction is therefore the identification *by the court*, with the assistance of the skilled reader, of the particular words or phrases in the claims that describe what the inventor considered to be the ‘essential’ elements of his invention.”

BRITISH CELANESE LTD v COURTAULDS LTD

(1935) 52 RPC 171 [UK]

The area of the territory in which in cases of this kind an expert witness may legitimately move is not doubtful. He is entitled to give evidence as to the state of the art at any given time. He is entitled to explain the meaning of any technical terms used in the art. He is entitled to say whether in his opinion that which is described in the specification on a given hypothesis as to its meaning is capable

210 BGH, Judgment of 31 March 2009, *Strassenbaumaschine* Case X ZR 95/05 [Germany].

of being carried into effect by a skilled worker. He is entitled to say what at a given time to him as skilled in the art a given piece of apparatus or a given sentence on any given hypothesis as to its meaning would have taught or suggested to him. He is entitled to say whether in his opinion a particular operation in connection with the art could be carried out and generally to give any explanation required as to facts of a scientific kind.

He is not entitled to say nor is counsel entitled to ask him what the specification means, nor does the question become any more admissible if it takes the form of asking him what it means to him as an engineer or a chemist. Nor is he entitled to say whether any given step or alteration is obvious, that being a question for the court.

The disadvantages of these methods are two-fold. In the first place time is wasted and money spent on what is not legitimate. In the second place there accumulates a mass of material which so far from assisting the judge renders his task the more difficult, because he has to sift the grain from an unnecessary amount of chaff.

In my opinion the trial courts should make strenuous efforts to put a check upon an undesirable and growing practice.

SACHTLER GMBH & CO KG v RE MILLER PTY LTD

[2005] FCA 788 [Australia]

Evidence can be given by experts on the meaning which those skilled in the art would give to technical or scientific terms and phrases and on unusual or special meanings given by such persons to words which might otherwise bear their ordinary meaning. Where the patent contains technical material, the Court must, by evidence, be put in a position of a person of the kind to whom the patent is addressed, a person acquainted with the surrounding circumstances of the state and the art and at the relevant time. However, if the evidence does not establish that such a technical meaning exists, words used in a patent specification should be given their ordinary meaning

The evidence of the skilled reader is not determinative of the construction of the document. It is evidence of how a skilled reader would have read the document at the relevant time. It is then for the Court to construe the document, giving such weight to the evidence as it sees fit.

The construction of the specification is for the Court, not for the expert witness.

E. THE DOCTRINE OF EQUIVALENTS

11. *Basis of doctrine:* The problem with which courts struggle in determining the scope of the protection given by the claims is to balance the interests of the patentee and those of the public. It is a question of balancing certainty with fairness. A literal approach to the interpretation of claims may lead to limiting the scope of the invention unduly while an expansive interpretation may lead to uncertainty. There has thus arisen different approaches, which Prof Cornish has described as the conflict between fence post claiming (marking the boundary of the invention) and sign post claiming (specifying the essential inventive concept), while in US jurisprudence the conflict has been described as between central claiming (describing the core principles of the invention) and peripheral claiming (where the claims describe the outer limits of the invention).²¹¹

Jonathan D. C Turner gave this exposition:

If [the interpreter] has been told (in the British tradition) that the claims are there to define the outer limits of the patentee's exclusive rights in the invention so that competitors know where they stand, he will interpret them relatively strictly. If, on the other hand, he has been told (in the German tradition) that the claims are guidelines identifying the principal features of the invention which have been described in more detail in the description and drawings, he will interpret the claims relatively liberally.²¹²

The basis of the doctrine (also called the pith and marrow doctrine) is that essential integers cannot be omitted or replaced (by equivalents) without infringing the claim. Equivalents are usually mechanical equivalents; chemical equivalents are possible but rare.²¹³ Logically, though, the question of equivalence ought never to arise because once an integer is inessential whatever the alleged infringer does in relation to it is irrelevant.

211 Donald S Chisum Patent Claim Interpretation in David Vaver and Lionel Bently *Intellectual Property in the New Millennium - Essays in Honour of William R. Cornish* (2004) p 98.

212 Purposive Construction – Seven Reasons Why Catnic Is Wrong *European Intellectual Property Review*, November 1999 and the *CIPA Journal*, August 1999.

213 *Beecham v Bristol* [1978] RPC 153 (HL) [UK].

12. *There is no general doctrine of equivalents:*

ROCKWATER LTD v TECHNIP FRANCE SA

[2004] EWCA Civ 381 [UK]

It further follows that there is no general “doctrine of equivalents”. Any student of patent law knows that various legal systems allow for such a concept, but that none of them can agree what it is or should be. Here is not the place to set forth the myriad versions of such a doctrine.

On the other hand, purposive construction can lead to the conclusion that a technically trivial or minor difference between an element of a claim and the corresponding element of the alleged infringement nonetheless falls within the meaning of the element when read purposively. This is not because there is a doctrine of equivalents: it is because that is the fair way to read the claim in context.

13. *Inessentials only.* The doctrine applies to inessential integers only.

RODI AND WIENENBERGER AG v HENRY SHOWELL LTD

[1969] RPC 367 (HL)

The facts: The patent in question related to expanding metal bracelets for wristwatches. The links in the bracelets were held together with U-shaped connecting bows. The alleged infringement differed from the claim in that C-shaped connecting bows were used instead of U-shaped ones. The alleged infringers failed to give any reason for their change of the design. Although both types of bracelets worked in essentially the same way, the House of Lords decided that there was no infringement. Interestingly, the South African Appellate Division, while adopting the English legal approach, came to the opposite conclusion on the facts.²¹⁴

I am not suggesting that the doctrine of “pith and marrow” is dead and do not resile from anything I said on this subject in the *Van der Lely* case. I am only protesting against its becoming used as a phrase embracing some undefined form of cheating where the alleged infringer is found not to have taken the essential features of the patentees’ claim. The doctrine, as has often been pointed out, has lost much of its importance, at least since the passing of the Patents Act, 1949. The modern form of claim covers all essential features, whereas in earlier days it was often necessary sometimes to search the specification for the ‘pith and marrow’ of what was claimed.

214 *Frank & Hirsch (Pty) Ltd v Rodi & Wienenberger AG* 1960 3 SA 747 (A).

This reference to mechanical equivalence can only relate to inessentials, for it is only where there are differences in inessentials, while the alleged infringement possesses all the essential features of integers of the claim, that there will be infringement. 'Pith and marrow' does not enlarge the scope of essentiality'.

First, the question is whether the relevant claim has been infringed. This is purely a question of construction of the claim read as a matter of ordinary language, in the light of the complete specification taken as a whole; but the claim must be construed as a document without having in mind the alleged infringement. What is not claimed is disclaimed. The claim must be read through the eyes of the notional addressee, the man who is going to carry out the invention described. There are many authorities on this, but it is unnecessary to review them, for I have already said enough to show that, in my view, this document must be read through the eyes of the common man at his bench.

In considering the claim the court must ascertain what are the essential integers of the claim; this remains a question of construction and no general principles can be laid down.

Secondly, the essential integers having been ascertained, the infringing article must be considered. To constitute infringement the article must take each and every one of the essential integers of the claim. Non-essential integers may be omitted or replaced by mechanical equivalents.

14. *What is essential depends on the form of the claim:*

OLIN CORPORATION v SUPER CARTRIDGE CO PTY LTD

(1977) 180 CLR 236 [Australia]

The principle that there may be infringement by taking the "pith and marrow" or the substance of an invention does not mean that there will be an infringement where the patentee has by the form of his claim left open that which the alleged infringer has done. And it does not affect the fundamental rule that there will be no infringement unless the alleged infringer has taken all of the essential features or integers of the patentee's claim.

15. *The application of the principle is limited:*

AZUKO PTY LTD v OLD DIGGER PTY LTD

[2001] FCA 1079 [Australia]

The invention must be defined with precision and with clarity in the claims. [The] application of this principle [of the functional equivalent] is limited to two possible situations:

- where the alleged infringing article possesses a mechanical equivalent of an inessential integer; or
- where upon a too literal construction of an integer of a claim, the alleged infringing device would escape infringement.

In both these situations, it is necessary to determine first whether or not the alleged infringing article possesses each and every integer of the claim. In considering the [first] question of a mechanical equivalent of an inessential integer, an assessment is made of the 'essentiality' of the integers taken or omitted by the alleged infringing device. But this is a very narrow class of case. Infringement was not demonstrated merely by showing the performance of substantially similar functions by the apparatus.

16. *Matter of interpretation:* It is a matter of interpretation to determine whether an integer is essential or not. In this regard it is not possible to limit the inquiry to the wording of the claim.

STAUFFER CHEMICAL CO v SAFSAN

1987 (2) SA 331 (A) [South Africa]

To ascertain what are and what are not the essential features or integers of a claimed invention the specification must be read and interpreted purposively or realistically, with the understanding of persons with practical knowledge and experience of the kind of work in which the invention was intended to be used and in the light of what was generally known by such persons at the date of the patent, which date by our law is the priority date of the claim.

Obviously, the fact that a claim incorporates a particular feature does not alone suffice to make that feature an essential one. Otherwise the problem would not arise. In general, if the feature is in fact essential to the working of the claimed invention, then it must be regarded as an essential feature.

On the other hand, a patentee may indicate in his specification, either expressly or by implication, that he regards a particular integer as essential; and in that event it must be treated as essential and it matters not that it may not be essential to the working of the invention.

Where, however, a feature is not essential to the working of the invention and the patentee has not indicated that he regards it as an essential integer, then in general it may be treated as unessential and an alleged infringer may be held to have infringed the claim notwithstanding that his product or process does not incorporate that feature or substitutes an equivalent for it.

F. PURPOSIVE CONSTRUCTION

17. *The origin of purposive construction:* The judgment of the House of Lords in *Catnic Components Ltd v Hill & Smith Ltd* [1982] RPC 183 introduced the term “purposive construction” into patent law. The judgment has given rise to a mass of literature and massive problems, and has fueled litigation in common-law countries. But, after all has been said and done, it was not an earth-shattering judgment and, on the facts, fairly straightforward.

AZUKO PTY LTD v OLD DIGGER PTY LTD

[2001] FCA 1079 [Australia]

As Gummow J observed in *Nicaro Holdings Pty Ltd v Martin Engineering Co* (1990) 91 ALR 513, the decision of the House of Lords did not propound “any novel principle or new category of non-textual infringement”.

WHIRLPOOL CORP v CAMCO INC

2000 SCC 67 [Canada]

The key to purposive construction is therefore the identification by the court, with the assistance of the skilled reader, of the particular words or phrases in the claims that describe what the inventor considered to be the “essential” elements of his invention. This is no different, I think, than the approach adopted roughly 40 years earlier by Duff CJ in *JK Smit & Sons Inc v McClintock* [1940] SCR 279.

The ‘essential’ elements approach was established in earlier English cases such as *Marconi v British Radio Telegraph and Telephone Co* and more recent pre-*Catnic* decisions in that country.

The *Catnic* analysis therefore was not a departure from the earlier jurisprudence in the United Kingdom or in this country. It is no disrespect to Lord Diplock to suggest that at least to some extent he poured some fine old whiskies into a new bottle, skillfully refined the blend, brought a fresh clarity to the result, added a distinctive label, and *voilà* “purposive construction”. In *Catnic*, as in the earlier case law, the scope of the monopoly remains a function of the written claims but, as before, flexibility and fairness is achieved by differentiating the essential features (‘the pith and marrow’) from the unessential, based on a knowledgeable reading of the whole specification through the eyes of the skilled addressee rather than on the basis of ‘the kind of meticulous verbal analysis in which lawyers are too often tempted by their training to indulge’.

18. *The facts in Catnic:* *Catnic* sought to do away with what has been called an over-literal claim construction mindset. The facts were simple. The claim claimed a lintel, and its load-bearing had to be vertical. The question was whether the term “vertical” in context meant in strict geometrical terms 90 degrees off the horizontal or whether it meant something close to the true vertical that could do the job. The court found that the addressee would have understood the term in context with reference to its function and that the geometrical meaning was not intended. Put differently, the word “vertical” has more than one meaning; and sensibly and realistically the meaning that fits the purpose of the invention should apply. The cynic may have asked: Since the typical builder never builds something truly vertical, why should he have thought that this lintel had to be 90 degrees from the horizontal? It is fair to assume that the Court’s answer may have been different had the claim stated that the lintel had to be 90 degrees from the vertical. On the other hand, if the inventor did not have the geometrical meaning in mind, why did he not say substantially vertical?

19. *The Catnic judgment:* This is what the judgment had to say.

CATNIC COMPONENTS LTD v HILL & SMITH LTD

[1982] RPC 183

My Lords, a patent specification is a unilateral statement by the patentee, in words of his own choosing, addressed to those likely to have a practical interest in the subject matter of his invention (i.e. “skilled in the art”), by which he informs them what he claims to be the essential features of the new product or process for which the letters patent grant him a monopoly. It is those novel features only that he claims to be essential that constitute the so-called “pith and marrow” of the claim. A patent specification should be given a

purposive construction rather than a purely literal one derived from applying to it the kind of meticulous verbal analysis in which lawyers are too often tempted by their training to indulge. The question in each case is whether persons with practical knowledge and experience of the kind of work in which the invention was intended to be used, would understand that strict compliance with a particular descriptive word or phrase appearing in a claim was intended by the patentee to be an essential requirement of the invention so that *any* variant would fall outside the monopoly claimed, even though it could have no material effect upon the way the invention worked.

The question, of course, does not arise where the variant would in fact have a material effect upon the way in which the invention worked. Nor does it arise unless at the date of the publication of the specification it would be obvious to the informed reader that this [i.e. that the variant could have no material effect upon the way the invention works] was so. Where it is not obvious, in the light of then-existing knowledge, the reader is entitled to assume that the patentee thought at the time of the specification that he had good reason for limiting his monopoly so strictly and had intended to do so, even though subsequent work by him or others in the field of the intervention might show the limitation to have been unnecessary. It is to be answered in the negative only when it would be apparent to any reader skilled in the art that a particular descriptive word or phrase used in a claim cannot have been intended by a patentee, who was also skilled in the art, to exclude minor variants which, to the knowledge of both him and the readers to whom the patent was addressed, could have no material effect upon the way in which the invention worked.

20. *One is still at the end of the day concerned with the meaning of the language used:*

ROCKWATER LTD v TECHNIP FRANCE SA

[2004] EWCA Civ 381 [UK]

When ascertaining the inventor's purpose, it must be remembered that he may have several purposes, depending on the level of generality of his invention. Typically, for instance, an inventor may have one, generally more than one, specific embodiment as well as a generalized concept. It is the latter which matters when construing the claim, particularly the widest claim. Otherwise one is in danger of being unfair to the inventor. I put it this way in *Tickner v Honda* [2002] EWHC 8 (Patents) at paragraph 28:

“The whole approach goes by the sobriquet ‘purposive construction’. You learn the inventor’s purpose by understanding his technical contribution from the specification and drawings. You keep that purpose in mind when considering what the terms of the claim mean. You choose a meaning consistent with that purpose – even if that involves a meaning which, a-contextually, you would not ascribe to the word or phrase. Of course in this exercise you must also be fair to the patentee – and in particular must not take too narrow a view of his purpose – it is the widest purpose consistent with his teaching which should be used for purposive construction.”

Nonetheless purpose is not the be-all and end-all. One is still at the end of the day concerned with the meaning of the language used. It is the terms of the claims which delineate the patentee’s territory.

It follows that if the patentee has included what is obviously a deliberate limitation in his claims, it must have a meaning. One cannot disregard obviously intentional elements. Hoffmann LJ put it this way in *STEP v Empson* [1993] RPC at 522:

“The well known principle that patent claims are given a purposive construction does not mean that an integer can be treated as struck out if it does not appear to make any difference to the inventive concept. It may have some other purpose buried in the prior art and even if this is not discernible, the patentee may have had some reason of his own for introducing it.”

It also follows that where a patentee has used a word or phrase which, a-contextually, might have a particular meaning (narrow or wide) it does not necessarily have that meaning in context. A good example of this is the *Catnic* case itself – ‘vertical’ in context did not mean ‘geometrically vertical’, it meant ‘vertical enough to do the job’ (of supporting the upper horizontal plate).

21. *The issue of construction remains a unitary one:*

WHEATLEY v DRILLSAFE LTD

[2000] EWCA Civ 209

These passages in Lord Diplock’s speech in *Catnic* underline the fact that, in this context as elsewhere in the law, the issue of construction is ultimately a unitary one. The various matters arising under the second quoted paragraph, aim simply to assist in arrival at the proper

purposive and contextual interpretation. They assist, in particular, to decide “whether a feature embodied in an alleged infringement which fell outside the primary, literal or a-contextual meaning of a descriptive word or phrase in the claim (a variant) was nevertheless within its language as properly interpreted”.

G. THE EUROPEAN PATENT CONVENTION (EPC)

22. *The EPC:* The legal developments in the UK after the *Catnic* decision were affected by the accession by the UK to the EPC and the new Patents Act, which incorporated the principles of the EPC and its protocols. These developments are strictly of little legal consequence to non-EC countries but in practice, since courts of other jurisdictions look to the UK and continental courts for guidance, they impact on others.²¹⁵ Of importance is the fact that the EPC attempted to eliminate the perceived difference of interpretation between the civil systems and the common-law systems.

23. *The Protocol on the Interpretation of Article 69 EPC (2000) attempted to reconcile the previously divergent approaches to claim interpretation:* This is explained by Nicholas Fox.²¹⁶

The origins of the Protocol lie in an attempt to reconcile the previously divergent approaches to claim interpretation in Europe. In contrast to the common law ‘fence post’ approach in which patent protection was closely tied to the wording of the claims, civil-law countries such as Germany adopted a “sign post” approach where claims were seen as defining the general inventive concept or “Kerntheorie” of an invention. Under this “sign post” approach a patent would be infringed if the identified inventive concept were utilized even if the infringement did not fall literally within the wording of the claims. With the adoption of the Protocol, the German courts now accept that the claims are no longer merely a pointer towards a claimed inventive concept, and that the claims now define the boundaries of a monopoly.

24. *The Protocol:* The Protocol, accordingly, provides in Article 1 as follows:²¹⁷

215 Adam Bobker, Patent Litigation in Canada – The Use of the Protocol Questions in Light of Lord Hoffman’s Decision in *Kirin-Amgen v. Hoechst Marion Roussel Lt*” 85 *Canadian Bar Review*.

216 Divided by a common language: a comparison of patent claim interpretation in the English and US courts [2004] *EIPR* 528.

217 The November 2000 Protocol provides in respect of equivalents in Art. 2 as follows: “For the purpose of determining the extent of protection conferred by a European patent, due account shall be taken of any element which is equivalent to an element specified in the claims.” It is not yet in force.

Article 69 should not be interpreted in the sense that the extent of protection conferred by a European patent is to be understood as that defined by the strict, literal meaning of the words used in the claims, the description and drawings being employed only for the purpose of resolving ambiguity found in the claims.

Neither should it be interpreted in the sense that the claims serve only as a guideline and that the actual protection conferred may extend to what, from a consideration of the description and drawings by a person skilled in the art, the patentee has contemplated.

On the contrary, it is to be interpreted as defining a position between these extremes which combines a fair degree of protection for the patentee with a reasonable degree of certainty for third parties.

The UK Patents Act incorporated these provisions in Article 125 in these terms:

For the purposes of this Act an invention ... shall, unless the context otherwise requires, be taken to be that specified in a claim of the specification ... as interpreted by the description and any drawings contained in that specification, and the extent of the protection conferred by a patent or application for a patent shall be determined accordingly.

H. THE PROTOCOL QUESTIONS

25. *The courts' interpretation of the Protocol:* Different jurisdictions have approached the question of interpretation under the Protocol differently. This is best illustrated by the outcomes in different jurisdictions operating under the Protocol in the so-called *Epilady* litigation – litigation between Improver Corp, the patentee, and Remington, the alleged infringer. The case concerned a device for the removal of hair. The patent used a revolving metal spring and Remington a revolving plastic rod with cuts. Both work on the same principle. Some courts found infringement; others not.

26. *The three-stage English Improver inquiry:* The English courts interpret the Protocol as imposing a three-stage approach to claim construction. This approach is, however, simply a matter of convenience and does not apply in all instances.

IMPROVER CORP v REMINGTON CONSUMER PRODUCTS

[1990] FSR 181 [UK]

The language should be given a ‘purposive’ and not necessarily a literal construction. If the issue was whether a feature embodied in an alleged infringement which fell outside the primary, literal or a-contextual meaning of a descriptive word or phrase in the claim (a variant) was nevertheless within its language as properly interpreted, the court should ask itself the following three questions:

- Does the variant have a material effect upon the way the invention works? If yes, the variant is outside the claim. If no –
- Would this (i.e. that the variant had no material effect) have been obvious at the date of publication of the patent to a reader skilled in the art? If no, the variant is outside the claim. If yes –
- Would the reader skilled in the art nevertheless have understood from the language of the claim, that the patentee intended that strict compliance with the primary meaning was an essential requirement of the invention? If yes, the variant is outside the claim.

27. *The three-stage German inquiry – the Schneidmesser questions:* German courts have adopted another set of questions under the Protocol.²¹⁸ They are:

- Does the (accused) embodiment solve the problem underlying the (patented) invention with means which, although modified, have objectively the same effect? If not, there is no patent infringement.
- Was the skilled person enabled by his general technical knowledge to find, without inventive effort, the variant as means functioning (acting) alike (in the same way)? If not, there is no patent infringement.
- Are the skilled person’s considerations under question no. 2 so based on the patent claim that the skilled person considers (entertains, takes into account) the variant as an equivalent (in German: gleichwertig) solution? Put differently: are the considerations, which the skilled person must apply (in connection with question 2), so closely oriented to the essence of the technical teaching under protection that the skilled person will consider the variant with its modified means as equivalent to the solution provided by the invention as defined in the claims?

²¹⁸ The questions here stated are as formulated (translated) by Axel von Hellfeld *Patent Infringement in Europe, the British and the German Approach to Claim Construction or Purposive Construction versus Equivalency* a lecture presented at the IPTA European Masters Course Melbourne and Sydney, March 2007.

These questions have been the subject of criticism. According to Axel von Hellfeld:

The German approach to claim construction (interpretation) under the EPC was developed by the German *Bundesgerichtshof* (Federal Court of Justice, BGH) in some dozens of decisions, starting in the early eighties until now. That case law is characterized by a large number of headnotes (i.e. theoretical principles) and sophisticated criteria. The British Courts, on the other hand, are much more reluctant to issue generalized theoretical principles. They prefer plain English over stilted language.

The German approach, he argues, is based on the dichotomy of literal or identical use and the protection outside the scope of identity (the German “equivalent” infringement).

28. *The Dutch approach:*

EPILADY

IEPT19920220,

Court of The Hague [The Netherlands]

The doctrine that the scope of protection of a patent is determined by the essence of the patented invention has led to an approach by way of the aforementioned question - the infringement question - as employed by Remington: first “the” essential features of the invention have to be formulated, summarizing and all-embracing, as a result of which a new patent claim emerges, so to speak, after which the respondent’s device or method is tested against it.

An objection to such an approach is that, in cases where nothing or little more can be said about the patented invention than that the measure in question or the combination of measures “works”, a search is nevertheless made for “the” essential features, which can lead to far-reaching abstractions that should not play any part in the application of Article 30(2) of the Netherlands Patents Act and Article 69 of the European Patent Convention and the accompanying Protocol, and to the objection that, in cases where much more can be said about the patented invention, it is nevertheless not really possible to formulate “the” essential features reliably once and for all, so that, even if the attempt is made, the formulation is usually inspired by the infringement question requiring a specific answer and an appropriate choice of the known state of the art against which the invention is to be tested, all of which leads to the resulting

formulation being either too broad, or too narrow, or otherwise proving not appropriate to other cases in which a question of infringement of the patent concerned has to be answered.

The court therefore considers that the infringement question should not be answered in this way. This does not mean that the court believes that no account should be taken of what forms part of – what might be interpreted as – the essential aspects of the patented invention, but that care should be taken to investigate what the nature or operation and function are of the measure referred to in the patent claim that the third party has replaced in his working method or device with another that does not correspond to the wording of the patent claim, what the place is of (the function of) the measure concerned in the totality of the measures referred to in the claim, and that subsequently an assessment is made, partly with reference to the known state of the art, (a) of to what extent the inventor can fairly lay claim to a certain abstraction of the measures he has described and (b) to what extent that abstraction is not unfair to those people, third parties, who may base their actions on the trust that they will not afterwards be prohibited or lead to an obligation to pay damages.

The coil spring and the Remington component referred to should therefore be regarded, in the framework of the device as a whole, as variants of each other, each with its own advantages or disadvantages, in which certain characteristics of the Remington device can be such that this device is also patentable on those grounds.

The hair-gripping component of the Remington device did not belong to the known state of the art in the field of depilatory devices and was not obvious to the user of the coil spring that does belong to the state of the art. Under these circumstances the applicant has not failed in his obligation towards third parties to formulate the patent in such a way that it gives rise to as little uncertainty as possible, and it is fair that the applicant, who names the well-known coil spring on the grounds of the characteristics referred to in the consideration above as a component of the device for which a patent is requested, should also receive protection in respect of a hair-gripping device that has the same characteristics.

Whether such protection against third parties is unfair must be judged against what the craftsman in the Netherlands should expect concerning the scope of protection, while this expectation is obviously partly based on Dutch case-law.

The advice of the expert indicates, among other things, how in the department's opinion, Dutch experts view the scope of the patent's protection. On the basis of that advice, of the obviousness of the mechanical equivalence in the said circumstances and of the fairness referred to in the second sentence, of which third parties ought to take account in their expectations, the court takes the view that third parties ought to realize that the term "coil spring" in the patent claims merits such abstraction that a device such as Remington's is covered by the patent's scope of protection. [Translated from Dutch.]

In any event, the outcome of the *Epilady* litigation showed that different courts construed the same claims differently. No infringement was found in England, but otherwise in Germany and the Netherlands.

I. ENGLISH LAW ON INTERPRETATION: THE FINAL WORD?

29. *The final word?* The final word may now have been spoken in the UK on the approach to patent interpretation. In *Kirin-Amgen Inc v Hoechst Marion Roussel Ltd* [2004] UKHL 46, Lord Hoffman reviewed in great detail the history of and rationale behind patent interpretation. It is a lengthy judgment, encyclopedic and, although basically a restatement, worthwhile reading. The extracts that follow do not do justice to the judgment.

The facts: The patent, owned by Amgen, dealt with the production of EPO, a very successful anemia drug. Although the protein was known, the patent covered the production of the EPO using genetic engineering techniques to express exogenous DNA in host cells. The defendant, TKT, developed a separate technique for producing EPO by inserting an inducible promoter sequence upstream of the endogenous EPO gene in human cell lines. The claim of Amgen's patent under consideration covered the production of the EPO protein through expression of an exogenous DNA sequence in a host cell. Amgen argued that the host cell simply had to host exogenous DNA which included the TKT introduced promoter sequence. On the other hand, TKT argued for a narrower claim interpretation that the exogenous DNA covered by the claim could only be an exogenous EPO gene.

KIRIN-AMGEN INC v HOECHST MARION ROUSSEL LTD

[2004] UKHL 46 [HL]

(a) [Prior to 1977 interpretation was not regulated by statute]²¹⁹

219 These headings have been added in order to highlight the different points made in the judgment.

Until the Patents Act 1977, which gave effect to the European Patent Convention ('EPC') there was nothing in any UK statute about the extent of protection conferred by a patent. It was governed by the common law, the terms of the royal grant and general principles of construction. But the EPC and the [1977] Act deal expressly with the matter in some detail.

(b) [*The EPC and the Protocol expressed existing UK law*]

In stating unequivocally that the extent of protection shall be 'determined' (in German, '*bestimmt*') by the 'terms of the claims' (*den Inhalt der Patentansprüche*) the Convention followed what had long been the law in the United Kingdom.

Although the EPC thus adopted the United Kingdom principle of using the claims to determine the extent of protection, the Contracting States were unwilling to accept what were understood to be the principles of construction which United Kingdom courts applied in deciding what the claims meant. These principles were perceived as having sometimes resulted in claims being given an unduly narrow and literal construction. The Contracting Parties wanted to make it clear that legal technicalities of this kind should be rejected. On the other hand, it was accepted that countries which had previously looked to the 'essence of the invention' rather than the actual terms of the claims should not carry on exactly as before under the guise of giving the claims a generous interpretation.

(c) [*The nature of the original purely linguistic approach*]

It is impossible to understand what the first sentence of the Protocol was intending to prohibit without knowing what used to be the principles applied (at any rate in theory) by an English court construing a legal document. These required the words and grammar of a sentence to be given their 'natural and ordinary meaning, that is to say, the meanings assigned to the words by a dictionary and to the syntax by a grammar. This meaning was to be adopted regardless of the context or background against which the words were used, unless they were "ambiguous", that is to say, capable of having more than one meaning.

On the other hand, if the language of the claim "in itself" was ambiguous, capable of having more than one meaning, the court could have regard to the context provided by the specification and drawings. If that was insufficient to resolve the ambiguity, the

court could have regard to the background, or what was called the “extrinsic evidence” of facts which an intended reader would reasonably have expected to have been within the knowledge of the author when he wrote the document.

These rules, if remorselessly applied, meant that unless the court could find some ambiguity in the language, it might be obliged to construe the document in a sense which a reasonable reader, aware of its context and background, would not have thought the author intended.

(d) [*The linguistic approach was abandoned by Catnic*]

As it happens, though, by the time the Protocol was signed, the English courts had already begun to abandon them, not only for patent claims, but for commercial documents generally. It came to be recognized that the author of a document such as a contract or patent specification is using language to make a communication for a practical *purpose* and that a rule of construction which gives his language a meaning different from the way it would have been understood by the people to whom it was actually addressed is liable to defeat his intentions. It is against that background that one must read the well known passage in the speech of Lord Diplock in *Catnic* when he said that the new approach should also be applied to the construction of patent claims.

(e) [*Patent construction is an objective exercise*]

Construction, whether of a patent or any other document, is of course not directly concerned with what the author meant to say. Construction is objective in the sense that it is concerned with what a reasonable person to whom the utterance was addressed would have understood the author to be using the words to mean. Notice, however, that it is not, as is sometimes said, “the meaning of the words the author used”, but rather what the notional addressee would have understood the *author* to mean by using those words. The meaning of words is a matter of convention, governed by rules, which can be found in dictionaries and grammars. What the author would have been understood to mean by using those words is not simply a matter of rules. It is highly sensitive to the context of and background to the particular utterance. It depends not only upon the words the author has chosen but also upon the identity of the audience he is taken to have been addressing and the knowledge and assumptions which one attributes to that audience.

(f) [*The notional addressee is the person skilled in the art*]

In the case of a patent specification, the notional addressee is the person skilled in the art. He (or, I say once and for all, she) comes to a reading of the specification with common general knowledge of the art. And he reads the specification on the assumption that its purpose is both to describe and to demarcate an invention – a practical idea which the patentee has had for a new product or process – and not to be a textbook in mathematics or chemistry or a shopping list of chemicals or hardware.

(g) [*Purposive construction does not extend the meaning of the words*]

It is this insight which lies at the heart of ‘purposive construction’. If Lord Diplock did not invent the expression, he certainly gave it wide currency in the law. But there is, I think, a tendency to regard it as a vague description of some kind of divination which mysteriously penetrates beneath the language of the specification. Lord Diplock was in my opinion being much more specific and his intention was to point out that a person may be taken to mean something different when he uses words for one purpose from what he would be taken to mean if he was using them for another.

“Purposive construction” does not mean that one is extending or going beyond the definition of the technical matter for which the patentee seeks protection in the claims. The question is always what the person skilled in the art would have understood the patentee to be using the language of the claim to mean. And for this purpose, the language he has chosen is usually of critical importance. The conventions of word meaning and syntax enable us to express our meanings with great accuracy and subtlety and the skilled man will ordinarily assume that the patentee has chosen his language accordingly.

(h) [*The doctrine of equivalents is a counter to literalism*]

At the time when the rules about natural and ordinary meanings were more or less rigidly applied, the United Kingdom and American courts showed understandable anxiety about applying a construction which allowed someone to avoid infringement by making an “immaterial variation” in the invention as described in the claims. In England, this led to the development of a doctrine of infringement by use of the “pith and marrow” of the invention as opposed to a “textual infringement”.

If literalism stands in the way of construing patent claims so as to give fair protection to the patentee, there are two things that you can do. One is to adhere to literalism in construing the claims and evolve a doctrine which supplements the claims by extending protection to equivalents. That is what the Americans have done. The other is to abandon literalism. That is what the House of Lords did in the *Catnic* case.

(i) [*Catnic is consistent with the Protocol*]

The *Catnic* principle of construction is therefore in my opinion precisely in accordance with the Protocol. It is intended to give the patentee the full extent, but not more than the full extent, of the monopoly which a reasonable person skilled in the art, reading the claims in context, would think he was intending to claim. Of course it is easy to say this and sometimes more difficult to apply it in practice, although the difficulty should not be exaggerated. The vast majority of patent specifications are perfectly clear about the extent of the monopoly they claim. Disputes over them never come to court. In borderline cases, however, it does happen that an interpretation which strikes one person as fair and reasonable will strike another as unfair to the patentee or unreasonable for third parties. That degree of uncertainty is inherent in any rule which involves the construction of any document. It afflicts the whole of the law of contract, to say nothing of legislation. In principle it is without remedy, although I shall consider in a moment whether uncertainty can be alleviated by guidelines or a 'structured' approach to construction.

(j) [*Equivalents are a guide to construction*]

Although article 69 prevents equivalence from extending protection outside the claims, there is no reason why it cannot be an important part of the background of facts known to the skilled man which would affect what he understood the claims to mean. That is no more than common sense.

(k) [*The Catnic and Improver questions are merely guidelines to interpretation*]

These questions [*Catnic* and *Improver*], which the Court of Appeal in *Wheatly v Drillsafe Ltd* [2001] RPC 133 dubbed "the Protocol questions" have been used by English courts for the past fifteen years as a framework for deciding whether equivalents fall within the scope of the claims. On the whole, the judges appear to have been comfortable with the results, although some of the cases have exposed the limitations of the method. When speaking of the

“*Catnic* principle” it is important to distinguish between, on the one hand, the principle of purposive construction which I have said gives effect to the requirements of the Protocol, and on the other hand, the guidelines for applying that principle to equivalents, which are encapsulated in the Protocol questions. The former is the bedrock of patent construction, universally applicable. The latter are only guidelines, more useful in some cases than in others.

The notion of strict compliance with the conventional meanings of words or phrases sits most comfortably with the use of figures, measurements, angles and the like, when the question is whether they allow for some degree of tolerance or approximation. That was the case in *Catnic* and it is significant that the ‘quintet’ of cases in which the German Bundesgerichtshof referred to *Catnic* and said that its approach accorded with that of the House of Lords were all concerned with figures and measurements. In such cases, the contrast with strict compliance is approximation and not the rather pretentious figures of speech mentioned in the Protocol questions. No doubt there are other cases, not involving figures or measurements, in which the question is whether a word or phrase was used in a strictly conventional or some looser sense. The Protocol questions are useful in many cases, but they are not a substitute for trying to understand what the person skilled in the art would have understood the patentee to mean by the language of the claims.

J. GERMAN LAW ON INTERPRETATION

30. Germany is also bound by the EPC and the Protocol. It is here used to illustrate the approach to interpretation by a country with a civil-law background. For this purpose a judgment of an English court by Laddie J will be used. It was a license case and the English court had to establish the scope of a patent under German law.

CELLTECH R & D LTD v MEDIMMUNE INC

[2004] EWHC 1124 [UK]

The current German law, like ours, seeks to implement the provisions of Art. 69 EPC and the Protocol. It would not be safe to assume that the outcome of applying the German approach would, in all cases, be the same as the outcome under our domestic law.

(a) [Pre-protocol German law]²²⁰

Under previous German patent law, a liberal approach to the scope of protection applied. There was infringement if the defendant used the 'general inventive idea' in the patent. Now the essential basis for determining the scope of protection is the claims. This was confirmed by the decision of the German Supreme Court, the Bundesgerichtshof ("BGH"), in *Formstein* (Moulded Kerbstone) BGHZ 98, 12 = GRUR 1986, 803, 6 IIC (1987) p795 (Annex 2):

"In contrast to the legal situation until 1978, the claims are not now merely the starting point but rather the essential basis for determining the extent of protection. Under the Patent Law 1981, the terms of the claim have to be determined by interpretation, taking the description and drawings into consideration. As the Protocol shows, the interpretation does not only serve the purpose of resolving an ambiguity found in the claims but also of clarifying the technical terms used in the claims as well as the limits and bounds of the invention described therein"

(b) [Post-protocol approach]

[The quotation from *Formstein* continued:]

"The extent of protection of a patent filed after January 1, 1978, is determined as regards the equivalent use of the invention, by the terms of the claims to be ascertained by interpretation. What must be considered is the scope of the invention as it may be recognized by a person skilled in the art. It has to be examined whether a person skilled in the art, based on the invention as claimed, is able to solve the problem solved by the invention as claimed with equivalent means, i.e. to achieve the desired result with different means also leading to that result. Means which the average person skilled in the art, due to his knowledge and skill and based on considerations oriented on the invention as claimed, can identify as being equivalent are generally covered by the extent of the protection conferred by the patent. This is required by the goal of fair remuneration for the inventor under consideration of the aspect of legal certainty."

Formstein is not only the foundation for the current approach to the law of infringement in Germany, but it is also the source of an additional defense, called the *Formstein* objection, which is to

the effect that the patent cannot be extended to cover equivalent embodiments if such embodiments were either known or were obvious in the light of the state of the art. This is similar to our *Gillette* defence.

(c) [*Construction is for the court*]

Before considering that case law, one general point should be made. Under German law, as under English law, it is for the court to construe the patent and to decide the issue of infringement. In doing that it must view the patent through the eyes of the notional skilled, but uninventive, addressee.

(d) [*Determining the semantic meaning as the first step*]

According to German law, the first step in determining whether there is infringement is to construe the “semantic” meaning of the claims. If the defendant’s product or process falls within that, there is infringement. If that type of infringement is not found, the next step is to determine how far away from the semantic meaning, if at all, the scope of protection extends. For this purpose the German courts adopt a three stage test which is similar, but not identical, to the *Improver* questions. As the BGH explained in *Custodial II*:

“The principles for determining the extent of protection are also to be applied if the patent claim contains specifications of figures or dimensions. Such details participate in the binding nature of the patent claim as the decisive basis for determining the extent of protection. The inclusion of figures or dimensions in the claim shows that they are intended to contribute to determining and hence to delimiting the subject matter of the patent. Consequently, such details must not be regarded as less binding, merely exemplary determinations of the protected technical teaching, as was considered possible in the case law of the legal situation in Germany before entry into effect of Art. 69 of the EPC, and the corresponding amendments of national legislation.

Like any element of the patent claim, specifications of figures and dimensions are as a matter of principle subject to interpretation. As in other aspects, the decisive factor is the way in which the person skilled in the art understands such details in the overall context of the patent claim, with the description and drawings again being used to illuminate this context. Account must be

taken of the fact that specifications of figures and dimensions, by virtue of their objective content, which will also dominate the interpretation by the person skilled in the art, are not uniform but may in different forms refer to factual constellations with very different contents.”

(e) [*The contextual approach*]

Thus the German courts take into account the fact that figures and dimensions are, or are capable of being, used to delimit the scope of protection. On the other hand, the way they are interpreted depends upon the context in which they are used. Furthermore, the BGH went on to explain that, because of their ability to be precise, figures and dimensions are different to mere verbal descriptions:

“These factors alone prevent the person skilled in the art always ascribing the same fixed meaning to specifications of figures, dimensions or ranges. However, as a rule, he will attach a higher degree of certainty and clarity to such details than to verbal descriptions of the elements of the teaching according to the invention [citation omitted]. Figures as such are unambiguous, while general concepts formulated in linguistic terms constitute a certain degree of abstraction from the object to which they refer. In addition, such concepts, if used in a patent specification, need not necessarily be used in the meaning attached to them by general technical linguistic usage; in this sense the patent specification can constitute its ‘own lexicon’. From the vantage point of the reader skilled in the art, the features given concrete form by means of the specification of figures and dimensions may be interpreted such that the objective success to be achieved according to the invention is determined more precisely and, where appropriate, more narrowly than would be the case for a purely verbal description. Since it is the applicant’s responsibility to ensure that everything is contained in the patent claim for which he requests protection, the reader of the patent specification is entitled to assume that this requirement has also been satisfied through the inclusion of figures in the wording of the patent claims. This applies all the more in that the applicant who specifies figures has particular occasion to be fully aware of the consequences of the wording of the claims for the limits of the patent protection requested.”

For this reason, a considerably stricter assessment is appropriate than was the practice under the law in Germany before 1978. As a matter

of principle, an unambiguous figure determines and delimits the protected object exhaustively in this respect; figures above or below are therefore as a rule no longer to be included within the subject matter of the patent claim.'

It will be seen that, as under English law, the German courts have to take into consideration the fact that the language of the claim is the patentee's choice and that the reader is entitled to assume that he knew what he was doing when seeking to define the monopoly he was seeking.

(f) [*The notional addressee*]

The BGH went on to explain that, even if the semantic meaning contained numerical limits, this did not necessarily avoid the possibility that such limits were subject to usual tolerances. In this as in other respects, whether tolerances are permissible is determined through the eyes of the notional addressee:

"the decisive factor is the semantic content of the patent claim to be determined with the assistance of the description and drawings. In another context, [a specified angle, e.g. 90 degrees] may therefore be regarded by the person skilled in the art as a magnitude to be complied with exactly. This also applies as a matter of principle to ranges of figures with limit values. An interpretation that a value must be complied with exactly will above all correspond to the interpretation of the person skilled in the art following the realization that this is a 'critical' value. Accordingly, the way in which a specific figure or dimension in the patent claim is to be understood is a question of the interpretation by the person skilled in the art in the individual case, which is a matter to be determined by the trial judge."

(g) [*The application of the Improver questions*]

A German court must also determine whether the patent monopoly extends beyond the semantic meaning of the claims. As indicated above, this involves a three stage test which is similar to the Improver questions. The nature of the test was indicated as follows in *Custodial II*:

"Accordingly, for an embodiment departing from the literal wording of the patent claim to be within the extent of protection, it is not sufficient that (1) it solves the problem underlying the invention with modified but objectively equivalent means and (2) specialist knowledge enables the person skilled in the art to

recognize the modified means as being equivalent. In the same way that the same effect cannot be determined without focusing on the patent claim, in addition (3) the considerations that the person skilled in the art must apply must focus on the semantic content of the technical teaching protected in the patent claim in such a way that the person skilled in the art would consider the different embodiment with its modified means as being the specific equivalent solution.

As with other elements of the patent claim, the effect according to the claim must not be determined without taking account of the figures and dimensions contained in the claim. Consequently, as a matter of principle it is not sufficient for the inclusion of different embodiments within the extent of protection that in the interpretation of the person skilled in the art the effect of the invention otherwise occurs independently of compliance with the figures. If no other figure than the value according to the claim appears to be equivalent to the person skilled in the art, the extent of protection does not go beyond the semantic content of the patent claim. In the interpretation of the person skilled in the art the effect of the feature determined by figures according to the claim is in such event determined by (exact) compliance with a figure and can therefore necessarily not be obtained by a different figure. In such a case, it is not sufficient for the person skilled in the art to realize that a teaching abstracted from the figures is technically reasonable.

The applicant will not always recognize and exhaust the entire technical contents of the invention; irrespective of the question whether this is legally possible, he is not obliged by law to do so. If, when observed objectively, the patent is restricted to a narrower wording of the claim than would be appropriate according to the technical content of the invention, and thus compared with the state of the art, the specialist in the field is entitled to rely on the fact that protection is correspondingly restricted. The patent holder is then prevented from subsequently claiming protection for something he has not placed under protection. The same applies even if the person skilled in the art realizes that the effect of the invention as such (in the narrower case discussed above) could be achieved beyond the range protected in the patent claim.”

This appears to be saying that, although it may be obvious to the notional reader that other variants will work as well, they are not

covered by the patent if the reader would conclude from the teaching of the patent that the inventor intended not to cover such variants.

(h) [*The third Improver question*]

In its *Plastic Pipe* judgment, the BGH confirmed that this is essentially the same as the third *Improver* question:

“Ultimately in agreement with the aforesaid, the courts in the United Kingdom, in order to determine an infringement, examine whether the specialist public is entitled to expect and proceed on the basis that according to the patent the decisive factor will be precise compliance with the wording of the patent claim. Related to an individual feature of the patent claim, the issue is whether the feature in question appears to the person skilled in the art as one that can be used exclusively in accordance with the meaning of the words, if the claimed teaching on the technical action to be complied with. Such an interpretation is possible particularly in the case of figures and measurements.”

OCCLUTECH GMBH v DR. ROBERT MOSZNER

BGH, judgment of 10 May 2011 - X ZR 16/09 (Occlusion device)²²¹

Certainly, the patent in suit teaches, from a philological viewpoint, several clamps, and furthermore prescribes that these clamps are used to clamp the strands at the opposing ends of the device, thus at both proximal and distal end. However, the person skilled in the art would not stop at this purely linguistic understanding. He would see that the clamps served to bundle the strands, regardless of whether the strands were left in the extended condition or their ends were superimposed on each other by being bent over, because this would not cause both strand ends to cease to exist. The person skilled in the art would therefore assume from this that claim 1 also includes in its technical meaning executions in which both strand ends were laid on top of each other and were only bundled at one end of the device

Also wrong is the objection of the defendants, supported by the decision of the court in *The Hague*, in the Dutch infringement proceedings, that the applicant waived patent protection in the grant procedure for embodiments according to paragraph 27, because the grant files were not in principle admissible interpretation

221 The translation was derived from the blog <http://www.eplawpatentblog.com/eplaw/>.

material. The person skilled in the art, who would not infer from the patent document that – as opined by the defendants – parts of the description ought to have been deleted, would understand the text references concerned as explanation of the protected subject matter and attempt to bring them into a meaningful context, in which there were no contradictions.

According to the guidance in Art. 69 (1), first sentence EPC, the extent of the protection conferred by a patent shall be determined by the claims. In order that this stipulation can take effect in such a way that the aims of Article 1 of the Protocol on Interpretation are achieved, it is firstly necessary to determine, taking into account the description and drawings, the technical meaning which is attributed to the wording of the claim from the point of view of the person skilled in the art. Although a literal understanding of the claims is not suitable in order to grasp the protected subject matter, nor may the subject matter of protection be extended by generalization of concrete solutions stated in the claim. In particular, a narrower claim cannot be interpreted according to the criterion of a more broadly worded description.

On the contrary, the claim takes precedence over the description. Anything not reflected in the claims cannot come under the protection of the patent. The description and the drawings are to be consulted in order to interpret the claims, since they serve as explanation of the claims. Description and drawings are therefore to be consulted in order to determine the meaning of the claim. However, their consultation must lead neither to an extension of the content nor to a substantive limitation of the subject matter defined by the wording of the claim. If the technical teaching of the description and the technical teaching of the claim cannot be reconciled, the claim is authoritative.

In the event of contradictions between the claims and the description, those parts of the description which have not been reflected in the claims, are in principle not included in the patent protection. The description can only be taken into account insofar as it can be read as an explanation of the subject matter of the claim.

Also the consideration that the expert would endeavor, in principle, to read the patent document in a meaningful context and, in case of doubt, to understand its overall content in such a way that no contradictions arise does not lead, here, to an inclusion of the disputed embodiments, which correspond in this respect, in the

subject matter of claim 1 of the patent in suit. This principle is namely limited by the precedence of the claim. If, as in this case, the wording of the claim cannot be reconciled with a point in the description, the description cannot be consulted as a “correction” of the claim; otherwise this would be a violation of the principle of the precedence of the claim.

It is therefore also unnecessary to discuss here whether the principle that one must not have recourse to processes in the grant proceedings which have not been reflected in the also prohibits having recourse to patent publications such as the officially published patent application or earlier versions of the patent document, perhaps amended later in the opposition proceedings or in the limitation procedure, if the content of the authoritative version of the patent document is only revealed by a comparison of these and hence has also led to a reflection therein.

K. JAPANESE LAW ON EQUIVALENTS

31. *The Japanese approach:* The courts of Japan have a somewhat different approach.

BALL SPLINE BEARING CASE

Japan Supreme Court
Feb 4, 1998

In a patent infringement case, when making a determination as to whether a product manufactured or sold by an accused infringer or a process employed by same falls within the technical scope of a patented invention, the technical scope of the patented invention must be determined based on the invention recited in the patented claim.

In a case where the invention recited in the patented claim includes a part that is different from the accused device, the accused device is considered as not falling within the technical scope of the patented invention. In such case, however, it is reasonable to deem the accused device an equivalent to the invention recited in the patented claim, and therefore to fall within the technical scope of the patented invention, if the following five tests are met:

Positive Tests:

Test 1: Such different part is not an essential part of the patented invention (non-essentiality).

Test 2: Even if such different part is interchanged with a part of

the accused device, the objects of the patented invention can be achieved, and the same advantages attained by the accused device (interchangeability).

Test 3: Such interchange would have been easily conceived by a person skilled in the art at the time of manufacturing the accused device (ease of interchangeability).

Negative Tests:

Test 4: The accused device was not the same as publicly known art at the time of filing the application, or could not have been easily conceived by a person skilled in the art based on the publicly known art at the time of filing the application (exclusion of publicly known art).

Test 5: There is no special circumstance such as where the accused device was intentionally excluded during the prosecution of the patent application (file wrapper estoppel).

32. *Comment:* In its *Case Book of Intellectual Property Rights (1)* 2003, the Japan Patent Office Asia-Pacific Industrial Property Centre commented on these tests in these terms:

(i) As for Test 1 (non-essentiality)

The “essential part” means a characteristic or core portion recited in a claim that is a basis for its technical solution unique to the claimed invention. If a patented invention is different from an accused product regarding an essential part, the technical idea of the patented invention differs from the accused product and therefore it is natural that its patent right cannot cover the accused product. In examining whether or not a portion recited in a claim constitutes an essential part, not only the claim but also specification should be considered when comparing close prior arts.

(ii) As for Test 2 (interchangeability)

Interchangeability is found when, even after a part of component in a patented claim is replaced with a corresponding part of an accused product, the same operational advantages of the patented invention can still be attained in the accused product. The operational advantages should be determined based on the specification. It should be carefully studied what advantage is obtained by what component in the claim, and what advantage is lost due to a lack of a component in the claim.

(iii) As for Test 3 (ease of interchangeability)

Whereas the previous high court determined the ease of interchangeability at the time of filing the patent application, the Supreme Court held that the ease of interchangeability should be determined at the time of manufacturing the accused product. The extent of the easiness of interchangeability is considered to be easier to meet than the extent of easiness required for a finding of lack of inventive step stipulated in Article 29 (2) of the Patent Law. In determining the ease of interchangeability, prior art documents should be useful.

(iv) As for Test 4 (exclusion of publicly known art)

The Supreme Court held that a technology that has been publicly known at the time of filing the patent application or could have been easily invented by a person skilled in the art based on such publicly known technology at the time of filing is not patentable (Article 29), and that such technology should naturally belong to public domain properties and should not be monopolized. This is the reason that under Test 4 patent-free publicly known technology is an affirmative defense. This test does not mean that the patented invention could be easily conceived but rather that the patent right cannot be enforced with respect to a product that is easily obtainable from the prior art at the time of filing an application for patent.

(v) As for Test 5 (file wrapper estoppel)

The Supreme Court for the first time held that the application of the doctrine of equivalents is prevented by file wrapper estoppel. The Supreme Court stated that if the applicant intentionally excluded an accused product from the scope of the claims, or acknowledged that the accused product does not fall within the scope of the claims during the prosecution of the patent application, then the patentee is precluded from later asserting his claims against the accused product in a manner contrary to or inconsistent with his earlier acknowledgement.

L. US LAW ON EQUIVALENTS

33. The US law on equivalents differs in material respects from that of other common-law countries. It was established by the decision of the Supreme Court in *Graver Tank & Mfg Co v Linde Air Products Co* 339 US

605 (1950). The main cause of the difference is the fact that, in the USA, the patent as granted is not the exclusive memorial of the scope of the patent protection, and that extrinsic evidence relating to the prosecution history is admissible in order to interpret the specification and claims.²²² This rule, which is not accepted in other common-law countries, gave rise to the concept of prosecution history or file-wrapper estoppel (argument and amendment estoppel). These matters were the subject of later Supreme Court judgments in *Warner-Jenkinson v Hilton Davis* 520 US 17 (1996) and *Festo Corporation v Shoketsu Kinzoku Kogyo Kabushiki Co* 122 S Ct 1831 (2002). Because of the limited application of these principles, the basics only will be set out.

34. US precedents on equivalents, consequently, may not be applicable without more in other common-law jurisdictions. As the Canadian Supreme Court said in relation to file-wrapper estoppel:²²³

To allow such extrinsic evidence for the purpose of defining the monopoly would undermine the public notice function of the claims, and increase uncertainty as well as fuelling the already overheated engines of patent litigation. The current emphasis on purposive construction, which keeps the focus on the language of the claims, seems also to be inconsistent with opening the Pandora's Box of file wrapper estoppel.

35. *An English view of US law:*

CELLTECH CHIROSCIENCE LTD v MEDIMMUNE INC

[2002] EWHC 2167 (Patents) [UK]

The facts: Because of the terms of a license agreement, the English court was called upon to decide the scope of a patent with reference to US law. The judgment by Jacob J provides a useful insight from the vantage point of an outsider. It went on appeal (*Celltech Chiroscience Ltd v Medimmune Inc* [2003] EWCA Civ 1008 (17 July 2003)) where the principles were also discussed. For present purposes the judgment of Jacob J will suffice.

In the US the law as to how the scope of a patent is determined is different from that in Europe. There is no express provision in Europe for a doctrine of equivalents. By this I mean a rule by which there may be infringement even if the accused product falls outside the meaning of the words of the claim when understood in context.

222 There is a similar rule in Japan and The Netherlands.

223 *Free World Trust v Électro Santé Inc* 2000 SCC 66 [Canada]. So, too, *Kirin-Amgen Inc v Hoechst Marion Roussel Ltd* [2004] UKHL 46 [UK]. But, as mentioned, Japan accepts the doctrine.

US patent law, by contrast, does have an explicit rule about equivalents. To my mind one of the best expositions of the reason for the rule remains that of Judge Learned Hand in *Royal Typewriter v Remington* (1948) 168 F 2d 691; 77 USPQ 517 (2d Cir):

“After all aids to interpretation have been exhausted and the scope of the claims has been enlarged as far as words can be stretched, on proper occasions courts make them cover more than their meaning can bear. If they applied the law with inexorable rigidity, they would never do this. [But] at times they resort to the doctrine of equivalents to temper unsparing logic and prevent an infringer from stealing the benefit of the invention.”

The US also has a further doctrine of patent law going by the name of “prosecution history (colloquially ‘file wrapper’) estoppel”. This rule is based on the broad notion that a patentee may not go back on anything he has said or represented to the United States Patent and Trademark Office in the course of prosecution of his patent.

Both rules are judge-made, to be ascertained from the rules laid down in the cases decided by the US Federal Courts. In recent years the higher US courts have been much concerned with both the doctrine of equivalents and file wrapper estoppel. The basic rules as regards equivalents are now that laid down in a pair of Supreme Court cases, *Markman v Westview Instruments* 517 US 370 (1996) and *Warner-Jenkinson v Hilton Davis* 520 US 17 (1996). *Markman* decided that the construction of a patent claim was a question of law for the court, not a jury question. That is not to say that expert evidence is not receivable – on the contrary it is. Most patent claims these days are only intelligible to a lawyer when the background technology (and particularly the jargon of the ‘trade’) has been explained. *Hilton-Davis* decided that the doctrine of equivalents remained alive and well following the 1952 revision of the US Patent Act. But it also reined in the doctrine. Justice Thomas, giving the opinion of a unanimous Supreme Court said this:

“We do, however, share the concern of the dissenters below that the doctrine of equivalents, as it has come to be applied since *Gruer Tank*, has taken on a life of its own, unbounded by the patents claims. There can be no denying that the doctrine of equivalents, when applied broadly, conflicts with the definitional and public-notice functions of the statutory claiming requirement.”

The reining in was achieved by adopting the solution of the late Judge Helen Nies in the CAFC. Justice Thomas expressed the modern rule thus:

“Each element contained in a patent claim is deemed material to defining the scope of the patented invention, and thus the doctrine of equivalents must be applied to individual elements of the claim, not to the invention as a whole. It is important to ensure that the application of the doctrine, even as to an individual element, is not allowed such broad play as to effectively eliminate that element in its entirety.”

INDUSTRIAL DESIGNS

CHAPTER XIII

1. *The Paris Convention:* The Paris Convention recognises industrial designs as industrial property without defining it. Member countries are obliged to protect industrial designs and to apply the principle of national treatment to nationals of the other Member countries. The protection of industrial designs may not be subject to forfeiture due to, for instance, non-working. In this respect they differ from patents.

The Convention also refers to utility models without defining them. According to Japanese law, for instance, a utility model is a device which is industrially applicable and which relates to the shape or construction of the device, and “device” is in turn defined as the creation of technical ideas by which a law of nature is utilized. However, since there is no convention obligation to recognise utility models, the issue is not discussed.

2. *The TRIPS Agreement:* The protection of industrial designs is also required by the TRIPS Agreement but it is silent about utility models. It lays down the requirements for the validity and the minimum term of protection of industrial designs without, once again, defining them. There is in addition a special provision relating to textile designs.

Articles 25 and 26 provide as follows:

- Members must provide for the protection of independently created industrial designs that are new or original.
- Members may provide that designs are not new or original if they do not significantly differ from known designs or combinations of known design features.
- Members may provide that such protection will not extend to designs dictated essentially by technical or functional considerations.
- Each Member must ensure that requirements for securing protection for textile designs, in particular in regard to any cost, examination or publication, do not unreasonably impair the opportunity to seek and obtain such protection. Members are free to meet this obligation through industrial design law or through copyright law.
- The owner of a protected industrial design must have the right to prevent third parties not having the owner’s consent from making, selling or importing articles bearing or embodying a design which is a copy, or substantially a copy, of the protected design, when such acts are undertaken for commercial purposes.
- Members may provide limited exceptions to the protection of industrial designs, provided that such exceptions do not unreasonably conflict with the normal exploitation of protected

industrial designs and do not unreasonably prejudice the legitimate interests of the owner of the protected design, taking account of the legitimate interests of third parties.

- The duration of protection available must amount to at least 10 years.

3. Definition: In the absence of a definition of a design in international instruments it is impossible to find commonality in the laws of different countries. In Japan a design is defined as a shape, pattern of colour in an article which produces an aesthetic impression through the sense of sight and which is capable of being used in industrial manufacture.

This means generally that:

- a design consists of a shape, configuration and/or ornamentation;
- it must be applied to an article; and
- the features of the design must be judged visually;
- it does not matter whether or not the design has any aesthetic quality.

To be valid a design must be:

- new or²²⁴
- original (i.e. independently created).

It may, in certain jurisdictions such as the UK, not involve a method or principle of construction, and any feature which is necessitated solely by the function which the article is intended to perform is not entitled to design protection.

4. Council Regulation (EC) No 6/2002 of 12 December 2001 on Community designs: This regulation²²⁵ applies to Community designs in the European Union. It does not replace national laws of EU Member States. It defines a design as

the appearance of the whole or a part of a product resulting from the features of, in particular, the lines, contours, colours, shape, texture and/or materials of the product itself and/or its ornamentation²²⁶.

A design is entitled to be protected by a Community design to the extent that it

224 Some laws require novelty and originality.

225 Amended by Council Regulation (EC) No 1891/2006 of 18 December 2006. The consolidated version of Regulation No. 6/2002 is available at: <http://eur-lex.europa.eu/LexUriServ/LexUriServ.do?uri=CONSLEG:2002R0006:20070101:EN:PDF>.

226 Article 3(a) of Council Regulation (EC) No 6/2002 of 12 December 2001 on Community designs.

- is new; and
- has individual character.

A design is considered to be new if no identical design has been made available to the public before the date on which the design for which protection is claimed has first been made available to the public (in the case of an unregistered Community design) or before the date of filing of the application for registration of the design for which protection is claimed, or the date of priority, if any (in the case of a registered Community design). Designs are deemed to be identical if their features differ only in immaterial details.

A design is considered to have individual character if the overall impression it produces on the informed user differs from the overall impression produced on such a user by any design which has been made available to the public before the above mentioned relevant dates.

5. UK law: The Registered Designs Act 1949, before amendment, defined a design as features of shape, configuration, pattern or ornament applied to an article by any industrial process or means, being features which in the finished article appeal to and are judge solely by the eye, but did not include a method or principle of construction etc. which are dictated solely by function. The Act has been amended under the influence of the EU and now provides as follows:

- “Design” means the design of any aspect of the shape or configuration (whether internal or external) of the whole or part of an article.
- Design right is a property right which subsists in an “original” design. A design is not “original” if it is commonplace in the design field in question at the time of its creation.
- Design right does not subsist in:
 - a method or principle of construction,
 - features of shape or configuration of an article which—
 - enable the article to be connected to, or placed in, around or against, another article so that either article may perform its function, or
 - are dependent upon the appearance of another article of which the article is intended by the designer to form an integral part, or
 - surface decoration.

6. Registration: Design rights are usually dependent upon registration and, in that regard, are similar to patent rights. The result of this is that infringement

of a design right differs from copyright infringement: copyright infringement requires that the second (infringing) work must have been derived (copied) from the other while this is not required of design infringement - the only issue is one of similarity, irrespective of independent creation.

Some systems recognize unregistered design rights but their term of protection is substantially shorter than that of registered design rights. The Community Designs Regulation provides an example:

A design which meets the requirements [for validity] shall be protected by an unregistered Community design for a period of three years as from the date on which the design was first made available to the public within the Community²²⁷.

Upon registration by the Office, a design which meets the requirements [...] shall be protected by a registered Community design for a period of five years as from the date of the filing of the application. [The period may be]renewed for one or more periods of five years each, up to a total term of of 25 years from the date of filing²²⁸.

7. US law: US law recognises design patents. A design consists of the visual ornamental characteristics embodied in, or applied to, an article of manufacture. Since a design is manifested in appearance, the subject matter of a design patent application may relate to the configuration or shape of an article, to the surface ornamentation applied to an article, or to the combination of configuration and surface ornamentation. A design for surface ornamentation is inseparable from the article to which it is applied and cannot exist alone. It must be a definite pattern of surface ornamentation, applied to an article of manufacture.²²⁹

A design patent protects only the appearance of the article and not structural or utilitarian features.

8. The overlap between designs and copyright: Many works that are entitled to design rights are, simultaneously, entitled to copyright, something recognized in the Community designs Regulation:

A design protected by a Community design shall also be eligible for protection under the law of copyright of Member States as from

227 Art. 11(1) of Council Regulation (EC) No 6/2002 of 12 December 2001 on Community designs.

228 Art. 12 of Council Regulation (EC) No 6/2002 of 12 December 2001 on Community designs.

229 http://www.uspto.gov/web/offices/com/iip/pdf/brochure_05.pdf. See further: *Egyptian Goddess, Inc. v Swisa Inc.*, 543 F.3d 665 (Fed. Cir. 2008).

the date on which the design was created or fixed in any form. The extent to which, and the conditions under which, such a protection is conferred, including the level of originality required, shall be determined by each Member State²³⁰.

This has given rise to practical problems, something recognised in the second sentence quoted, because it means that spare or body parts of motor vehicles may be protected for a minimum of 50 or 70 years, something many laws consider to be unacceptable.

The law in Singapore, for example, states that the making of any useful article in three dimensions does not infringe the copyright in an artistic work if, when the useful article or reproduction is made, the artistic work has been industrially applied at any time before the useful article or reproduction is made. An artistic work is applied industrially if, for instance, more than 50 reproductions in three dimensions are made of it, for the purposes of sale or hire; and a useful article means an article having an intrinsic utilitarian function that is not merely to portray the appearance of the article or to convey information.

The South African Copyright Act provides that the copyright in an artistic work of which three-dimensional reproductions were made available, whether inside or outside the country, to the public by or with the consent of the copyright owner are not infringed if any person without the consent of the owner makes or makes available to the public three-dimensional reproductions or adaptations of the authorized reproductions, provided these reproductions primarily have a utilitarian purpose and are made by an industrial process.

9. *The overlap between trademarks and designs:* In view of the wide definition of a trademark to include for instance shapes or containers there is necessarily some overlap between the two areas. Because the term of protection of a trademark may be renewed indefinitely while the term of protection of a design may not, they have different commercial values. The point is, however, that an existing trademark may destroy the novelty of a design.

230 Art. 96(2) of Council Regulation (EC) No 6/2002 of 12 December 2001 on Community designs.

*BEIFA GROUP CO. LTD v OHIM AND SCHWAN-STABILO SCHWANHAÜBER
GMBH & CO. KG*

General Court, 12 May 2010, T-148/08, ECR, 2010, II-1681 [EU]

It should be borne in mind that the proprietor of an earlier [trade] mark – whether a Community mark or a mark registered in a Member State – has the right to prevent the use of a subsequent Community design both where use is made in that design of a sign which is identical to the earlier mark and the goods or services covered by the design are identical to those covered by the earlier mark, and where use is made in the Community design of a sign bearing such similarity to the earlier mark that, in view also of the fact that the goods or services covered by the mark are identical or similar to those covered by the design, there is a likelihood of confusion on the part of the public.

Given that the proprietor of an earlier mark – whether a Community mark or a mark registered in a Member State – has the right to prevent the use of a subsequent Community design in which use is made of a sign which is either identical to the earlier mark or similar to it, it is inconceivable that, in adopting Article 25(1)(e) of Regulation No 6/2002, the Community legislature intended to allow such a proprietor to submit an application for a declaration of invalidity of the design only where use was made in that design of a sign identical to the earlier mark, and not to allow such an application to be submitted where use was made in the design of a sign so similar that there would be a likelihood of confusion on the part of the relevant public.

Moreover, the proprietor of a mark – whether a Community mark or a mark registered in a Member State – cannot rely on the provisions referred to [...] above to prevent the use of a Community design which has been registered earlier and in which use is made of a sign identical or similar to the mark, since the proprietor of the Community design is able to defend itself against such a prohibition by applying for a declaration of invalidity in respect of the subsequent mark in question, where necessary, by way of counterclaim.

10. *Design and trademark infringements differ:* The question of design infringement involves a determination of whether the respondents' products embody the registered design or a design not substantially different from the registered design. The search is not for differences but for substantial ones. This test is not a trademark infringement test and the issue is not whether or not there is confusion or deception and it would therefore be

wrong to use concepts developed in a trade mark context such as imperfect recollection. The designs test is closer to the patent infringement test.

HONEYWELL ANALYTICS LIMITED v HEE JUNG KIM

Case R 609/2006-3 (OHIM) [EU]

The appellant's argument that a registered design cannot be assumed to exist for the purposes of distinguishing goods and services, is not pertinent. It is true that the essential purpose of a design is not to distinguish the products or services of an undertaking from those of other undertakings. However, that does not mean that in a commercial context, when applied to products, their packaging and get up, or when used in advertising, the contested RCD [registered Community design] may not be perceived as a sign by the relevant public.

An assessment can, therefore, be made of whether there is a risk that the relevant public might believe that the goods or services in question come from the same undertaking or, as the case may be, from economically-linked undertakings, within the meaning of Article 5(1)(b) TMD [Trademark Directive].

Within the meaning of that article, the assessment of the similarity of signs requires a global appreciation of their visual, aural or conceptual similarity, based on the overall impression they give, bearing in mind, in particular, their distinctive and dominant components.

The registered design and the earlier mark are visually similar [...]. Phonetically, the marks are identical [...]. Conceptually, the signs are identical [...]. In their overall impression, the signs are similar.

[...] [It] is conceivable that when the public encounters the logo, the subject of the contested RCD applied to products, their packaging or their get up, it will perceive that logo as an indication of the commercial origin of the products in question and not as a pure embellishment. Consequently, the contested RCD is liable to jeopardise the guarantee of origin which constitutes the essential function of the respondent's trade mark. The presence of the other elements in the contested RCD will not prevent the likelihood of the relevant public in the relevant Member States taking the products marketed with the appellant's logo as a line of products originating from the respondent undertaking or an undertaking economically connected to the respondent undertaking.

11. *Designs are assessed visually:*

PROCTER & GAMBLE COMPANY v RECKITT BENCKISER (UK) LTD

[2007] EWCA Civ 936 [United Kingdom]

The most important things in a case about registered designs are:

- The registered design;
- The accused object;
- The prior art.

And the most important thing about each of these is what they look like. Of course parties and judges have to try to put into words why they say a design has “individual character” or what the “overall impression produced on an informed user” is. But “it takes longer to say than to see” as I observed in *Philips v Remington* [1998] RPC 283 at 318. And words themselves are often insufficiently precise on their own.

It follows that a place for evidence is very limited indeed. By and large it should be possible to decide a registered design case in a few hours. The evidence of the designer, e.g. as to whether he/she was trying to make, or thought he/she had made, a breakthrough, is irrelevant. The evidence of experts, particularly about consumer products, is unlikely to be of much assistance: anyone can point out similarities and differences, though an educated eye can sometimes help a bit. Sometimes there may be a piece of technical evidence which is relevant – e.g. that design freedom is limited by certain constraints. But even so, that is usually more or less self-evident and certainly unlikely to be controversial to the point of a need for cross-examination still less substantial cross-examination.

It follows that the design history of the P&G design, and whether Reckitt copied was irrelevant.

EGYPTIAN GODDESS, INC. V. SWISA, INC

543 F.3d 665 (Fed. Cir. 2008)

The starting point for any discussion of the law of design patents is the Supreme Court’s decision in *Gorham Co. v. White*, 81 U.S. 511, 20 L. Ed. 731 (1871). That case involved a design patent for the handles of tablespoons and forks. In its analysis of claim infringement, the Court stated that the test of identity of design “must be sameness of appearance, and mere difference of lines

in the drawing or sketch ... or slight variances in configuration ... will not destroy the substantial identity." *Id.* at 526–27. Identity of appearance, the Court explained, or "sameness of effect upon the eye, is the main test of substantial identity of design"; the two need not be the same "to the eye of an expert," because if that were the test, "[t]here never could be piracy of a patented design, for human ingenuity has never yet produced a design, in all its details, exactly like another, so like, that an expert could not distinguish them." *Id.* at 527.

The *Gorham* Court then set forth the test that has been cited in many subsequent cases: "[I]f, in the eye of an ordinary observer, giving such attention as a purchaser usually gives, two designs are substantially the same, if the resemblance is such as to deceive such an observer, inducing him to purchase one supposing it to be the other, the first one patented is infringed by the other." 81 U.S. at 528. In the case before it, the Court concluded that "whatever differences there may be between the plaintiffs' design and those of the defendant in details of ornament, they are still the same in general appearance and effect, so much alike that in the market and with purchasers they would pass for the same thing — so much alike that even persons in the trade would be in danger of being deceived." *Id.* at 531.

However, in a series of cases tracing their origins to *Litton Systems, Inc. v. Whirlpool Corp.*, 728 F.2d 1423 (Fed. Cir. 1984), this court has held that proof of similarity under the ordinary observer test is not enough to establish design patent infringement. Rather, the court has stated that the accused design must also appropriate the novelty of the claimed design in order to be deemed infringing.

After a review of those authorities, which we examine in some detail below, we conclude that the point of novelty test, as a second and free-standing requirement for proof of design patent infringement, is inconsistent with the ordinary observer test laid down in *Gorham*, is not mandated by *Whitman Saddle* or precedent from other courts, and is not needed to protect against unduly broad assertions of design patent rights.

CLIPSAL AUSTRALIA (PTY) LTD v TRUST ELECTRICAL WHOLESALERS

[2007] ZASCA 24 [South Africa]

Important aspects to consider when determining the scope of the registered design protection flow from the definition of an

“aesthetic design”, namely that design features have to appeal to and be judged solely by the eye. First, although the court is the ultimate arbiter, it must consider how the design in question will appeal to and be judged visually by the likely customer. Secondly, this visual criterion is used to determine whether a design meets the requirements of the Act and in deciding questions of novelty and infringement. And thirdly, one is concerned with those features of a design that ‘will or may influence choice or selection’ and because they have some “individual characteristic” are “calculated to attract the attention of the beholder.” To this may be added the statement by Lord Pearson that there must be something “special, peculiar, distinctive, significant or striking” about the appearance that catches the eye and in this sense appeals to the eye.

12. Whose eyes – the informed user:

PROCTER & GAMBLE COMPANY v RECKITT BENCKISER (UK) LTD

[2007] EWCA Civ 936 [United Kingdom]

The “informed user” test makes sense: a user who has experience of other similar articles will be reasonably discriminatory – able to appreciate enough detail to decide whether a design creates an overall impression which has individual character and whether an alleged infringement produces a different overall impression.

It follows that the informed user is not the same as the “average consumer” of trade mark law. The informed user of design law is more discriminating. Whilst I do not say that imperfect recollection has no part to play in judging what the overall impression of design is, it cannot be decisive. I would say that what matters is what strikes the mind of the informed user when it is carefully viewed.

I think the Higher Provisional Court in Vienna, in holding that P&G’s design is not infringed by the Air-Wick product (decision of 6th December 2006, overruling a lower court decision granting an interim injunction) was right when it said:

«The ‘informed user’ will, in the view of the Appeals Court, have more extensive knowledge than an ‘average consumer in possession of average information, awareness and understanding’, in particular he will be open to design issues and will be fairly familiar with them.”

KWANG YANG MOTOR CO LTD v OHIM AND HONDA GIKEN KOGYO KABUSHIKI KAISHA

General Court, 9 September 2011, T-11/08 [EU]

Therefore, in assessing the individual character of the challenged design, it must be examined, [...] whether the overall impression that that design produces on an informed user is different from that produced by earlier designs [...], in particular, the design relied on by the applicant in support of the application for a declaration of invalidity, taking account of the degree of freedom enjoyed by the designer when developing the design.

The informed user:

According to the case-law, an 'informed user' [...] is neither a manufacturer nor a seller of the products in which the designs at issue are intended to be incorporated or to which they are intended to be applied. An informed user is particularly observant and has some awareness of the state of the prior art, that is to say the previous designs relating to the product in question that had been disclosed on the date of filing of the contested design [...].

Furthermore, the status of 'user' implies that the person concerned uses the product in which the design is incorporated, in accordance with the purpose for which that product is intended [...].

The qualifier 'informed' suggests in addition that, without being a designer or a technical expert, the user knows the various designs which exist in the sector concerned, possesses a certain degree of knowledge with regard to the features which those designs normally include, and, as a result of his interest in the products concerned, shows a relatively high degree of attention when he uses them [...].

However, that factor does not imply that the informed user is able to distinguish, beyond the experience gained by using the product concerned, the aspects of the appearance of the product which are dictated by the product's technical function from those which are arbitrary [...].

Therefore, an informed user is a person having some awareness of the existing designs in the sector concerned, without knowing which aspects of that product are dictated by technical function.

13. Overall impression:***SHENZHEN TAIDEN INDUSTRIAL CO. LTD v OHIM AND BOSCH SECURITY SYSTEMS BV***

General Court, 22 June 2010, T-153/08, ECR 2010, II-2517 [EU]

Since Article 6(1) of Regulation No 6/2002 refers to a difference between the overall impressions produced by the designs at issue, the individual character of a Community design cannot be examined in the light of specific features of various earlier designs.

Therefore, a comparison should be made between on the one hand, the overall impression produced by the contested Community design and, on the other, the overall impression produced by each of the earlier designs legitimately relied on by the party seeking a declaration of invalidity.

The obligation to make a comparison between the overall impressions produced by the designs at issue does not preclude the possibility of taking into consideration, as representations of one and the same earlier design, features which were made available to the public in different ways, in particular, first, by the publication of a registration and, second, by the presentation to the public of a product incorporating the registered design. The purpose of registering a design is to obtain an exclusive right in particular to make and market the product incorporating it, which means that the representations in the application for registration are, as a general rule, closely related to the appearance of the product placed on the market.

PROCTER & GAMBLE COMPANY v RECKITT BENCKISER (UK) LTD

[2007] EWCA Civ 936 [United Kingdom]

Once one has identified the notional “informed user” correctly and what he would know about the design corpus, one asks whether the accused product produces “a different overall impression” to such a person?

This test is inherently rather imprecise: an article may reasonably seem to one man to create “a different overall impression” and yet to another to do so. It is always so with the scope of rights in a visual work. You need to cover not only exact imitations, but also things which come “too close”. Whatever words you choose, you are bound to leave a considerable margin for the judgment of the tribunal.

Having said that, however, there are some general observations that can be made:

- For the reasons I have given above, the test [in the infringement context] is different not clearly different.
- The notional informed user is fairly familiar with design issues, as discussed above.
- Next is not a proposition of law but a statement about the way people (and thus the notional informed user) perceive things. It is simply that if a new design is markedly different from anything that has gone before, it is likely to have a greater overall visual impact than if it is surrounded by kindred prior art.
- On the other hand it does not follow, in a case of markedly new design (or indeed any design) that it is sufficient to ask “is the alleged infringement closer to the registered design or to the prior art”, if the former infringement, if the latter not. The test remains: is the overall impression different?
- It is legitimate to compare the registered design and the alleged infringement with a reasonable degree of care. The court must “don the spectacles of the informed user” to adapt the hackneyed but convenient metaphor of patent law. The possibility of imperfect recollection has a limited part to play in this exercise.
- The court must identify the overall impression of the registered design with care. True it is that it is difficult to put into language, and it is helpful to use pictures as part of the identification, but the exercise must be done.
- In this exercise the level of generality to which the court must descend is important. Here, for instance, it would be too general to say that the overall impression of the registered design is “a canister fitted with a trigger spray device on the top.” The appropriate level of generality is that which would be taken by the notional informed user.
- The court should then do the same exercise for the alleged infringement.
- Finally the court should ask whether the overall impression of each is different. This is almost the equivalent to asking whether they are the same – the difference is nuanced, probably, involving a question of onus and no more.

GRUPO PROMER MON GRAPHIC SA V OHIM AND PEPSICO INC

General Court, 18 March 2010, T-9/07, ECR 2010, II-981 [EU]²³¹

Since ‘conflict’ is not defined as such in Regulation No 6/2002, it is necessary to clarify that concept. [...] [The] Board of Appeal found [...] that a conflict arose between two designs when they produced the same overall impression on the informed user, and that in that connection the degree of freedom of the designer in developing the contested design had to be taken into account.

[...] [In] the case of a design registered in a Member State, the scope of the protection conferred by a design is to include any design which does not produce on the informed user a different overall impression and that, in assessing the scope of that protection, the degree of freedom of the designer in developing his design is to be taken into consideration.

In that connection, it must be noted, first of all, that in the vast majority of the language versions, the wording of Article 10(1) of Regulation No 6/2002 [...] indicates that the issue is one of a ‘different overall impression’. Two language versions [...] state that the issue is one of a ‘different overall visual impression’. However, since [...] a design is only the appearance of the whole or a part of a product, it must be found that the overall impression must [...] be a visual one. [...]

Next, it is apparent [...] that, in assessing whether a design is in conflict with a prior design, the designer’s freedom in developing his design is to be taken into consideration.

Consequently, Article 25(1)(d) of Regulation No 6/2002 must be interpreted as meaning that a Community design is in conflict with a prior design when, taking into consideration the freedom of the designer in developing the Community design, that design does not produce on the informed user a different overall impression from that produced by the prior design relied on.

14. *Comparing the whole:* The shape or configuration as a whole has to be considered, not only for purposes of novelty and originality, but also in relation to infringement.

231 The appeal against this judgment was dismissed: Judgment of the Court (Fourth Chamber) of 20 October 2011 — *PepsiCo, Inc., v Grupo Promer Mon Graphic SA, Office for Harmonisation in the Internal Market (Trade Marks and Designs)*(Case C-281/10 P)

OCULAR SCIENCES LTD v ASPECT VISION CARE LTD

[1997] RPC 289 [United Kingdom]

The proprietor can choose to assert design right in the whole or *any* part of his product. If the right is said to reside in the design of a teapot, this can mean that it resides in design of the whole pot, or in a part such as the spout, the handle or the lid, or, indeed, in a part of the lid. This means that the proprietor can trim his design right claim to most closely match what he believes the defendant to have taken.

15. *Methods or principles of construction are excluded:**LANDOR & HAWA INTERNATIONAL LTD v AZURE DESIGNS LTD*

[2006] EWCA Civ 1285 [United Kingdom]

The first issue centres round Azure's contention that Landor's claim for UKUDR [UK Unregistered Design Right] in the Expander Design is precluded by s 213(3)(a) of the Copyright, Designs and Patents Act 1988 which provides as follows:

"Design right does not subsist in a method or principle of construction."

This contention has given rise to two main arguments, one of principle and one essentially of fact. The argument of principle concerns the meaning and effect of [the provision]. The Judge held that the provision should be relatively narrowly construed, and that it did not apply merely because a design serves a functional purpose: it would not apply unless it can be shown that that purpose cannot be achieved by any other means.

In my opinion, the Judge's interpretation is correct. First, the section does not, as a matter of ordinary language, preclude a design being protected merely because it has a functional purpose. The language is perhaps a little opaque, but the words "method or principle" are important, and serve, in my view, to emphasise that mere functionality is quite insufficient to exclude a design from protection.

Secondly, it would be wrong in principle to conclude that a design incapable of protection merely because it serves a functional purpose. There is no simply no justification in policy or principle for such a conclusion. It would mean that a design which had only aesthetic features would be favoured over one with both aesthetic

and functional features, a curious consequence of legislation one of whose main functions is to reward imagination and inventiveness.

As Park J rightly observed in *A Fulton Co Ltd –v- Grant Barnett Ltd* [2001] RPC 257, at para 70:

“The fact that a special method or principle of construction may have been used in order to create an article with a particular shape or configuration does not mean that there is no design right in the shape or configuration. The law of design right will not prevent competitors using that method or principle of construction to create competing design as long as the competing designs do not have the same shape or configuration as the design right owner’s design has.”

Thirdly, the textbooks support this approach to interpretation.

UNFAIR COMPETITION: INTRODUCTION

CHAPTER XIV

- A. INTERNATIONAL STANDARDS (1-2)
- B. CIVIL-LAW SYSTEMS (3-4)
- C. THE COMMON-LAW APPROACH (5)
- D. THE MIXED-LAW APPROACH (6)

A. INTERNATIONAL STANDARDS

1. *Fair competition is of the essence of commerce:*

TAYLOR & HORNE (PTY) LTD v DENTALL (PTY) LTD

1991 (1) SA 412 (A)

It has often been said that competition is the life blood of commerce. It is the availability of the same, or similar, products from more than one source that results in the public paying a reasonable price therefor. Hence competition as such cannot be unlawful, no matter to what extent it injures the custom built up by who first marketed a particular product or first ventured into a particular sphere of commerce.

2. *The TRIPS requirements:* TRIPS requires of Members of the WTO to comply with the following provisions of the Paris Convention that deal with unfair competition.

Article 10*bis*:

(1) The countries of the Union are bound to assure to nationals of such countries effective protection against unfair competition.

(2) Any act of competition contrary to honest practices in industrial or commercial matters constitutes an act of unfair competition.

(3) The following in particular shall be prohibited:

- all acts of such a nature as to create confusion by any means whatever with the establishment, the goods, or the industrial or commercial activities, of a competitor;
- false allegations in the course of trade of such a nature as to discredit the establishment, the goods, or the industrial or commercial activities, of a competitor;
- indications or allegations the use of which in the course of trade is liable to mislead the public as to the nature, the manufacturing process, the characteristics, the suitability for their purpose, or the quantity, of the goods.

Laws dealing with unlawful trade practices, including laws against counterfeiting and monopolies, often cover much that would be protected by unfair competition.²³²

²³² Eg the Australian Trade Practices Act 1974 (Cth). Cf *Taco Company Of Australia Inc v Taco Bell Pty Ltd* (1982) 42 ALR 177; *Parkdale Custom Built Furniture Pty Ltd v Puxu Pty Ltd* (1982) 149 CLR 191.

B. CIVIL-LAW SYSTEMS

3. *German law*: Civil-law systems tend to recognize a general delict of unfair competition which, latterly, is amplified by a list of examples.²³³ One such instance is German law. The general proposition in § 3 of the German UWG Act is that:

acts of unfair competition likely to seriously impair competition to the disadvantage of competitors, consumers or other market participants are prohibited.

The law proceeds to provide a list of examples:

In particular, a person is acting unfairly, in the sense of Article 3, if he/she:

- undertakes competitive acts calculated to impair the freedom of consumers or other market participants to make choices, through the exertion of pressure, cruelty or other improper, undue influence;
- undertakes competitive acts likely to exploit the lack of economic experience, especially that of children or young people, the credulity, fear or desperation of consumers;
- obscures the promotional nature of competitive activities;
- does not clearly and unambiguously state the conditions for taking advantage of promotional measures such as price reductions, extras or gifts;
- does not clearly and unambiguously state the conditions for taking part in promotional competitions or contests;
- makes participation by consumers in a competition or contest contingent on purchasing a product or using a service – unless the competition or contest is by its very nature linked to that product or service;
- denigrates or defames the brand, products, services, activities or personal or business relationships of a competitor;
- makes or spreads claims, concerning the products, services or business of a competitor or concerning a business owner or a board member of a business, calculated to damage the economic interests of the business or the standing of the business owner, where those facts are not demonstrably true; if the communication is in private and if the communicator or recipient of the communication has a justified interest in it, the act is unfair only if the claims have been made or spread in contradiction of the truth;

²³³ Civil countries have, obviously, their own different laws. Cf Frauke Henning-Bodewig and Gerhard Schricker “New initiatives for the harmonisation of unfair competition law in Europe” [2002] *EIPR* 271.

- deliberately obstructs competitors;
- contravenes a legal provision intended to regulate market relationships in the interests of market participants;
- offers products or services that are imitations of the products or services of a competitor, if he/she:
 - avoidably deceives the recipient with regard to the commercial origin of the product or service,
 - improperly exploits or negatively affects the reputation of the product or service imitated, or
 - has dishonestly obtained the knowledge or equipment required for forgery.

4. *Japanese law:* Japanese law is more specific and defines the activities that amount to unfair competition in these terms:²³⁴

- acts of creating confusion with another person's goods or business by using an indication of goods or business (which means a name, trade name, trademark, mark, or container or package of goods used in relation to a person's business, or any other indication of a person's goods or business; the same shall apply hereinafter) that is identical or similar to said person's indication of goods or business that is well-known among consumers or other purchasers, or by assigning, delivering, displaying for the purpose of assignment or delivery, exporting, importing or providing through an electric telecommunication line the goods using such an indication;
- acts of using as one's own an indication of goods or business that is identical or similar to another person's famous indication of goods or business, or the act of assigning, delivering, displaying for the purpose of assignment or delivery, exporting, importing or providing through an electric telecommunication line the goods using such an indication;
- acts of assigning, leasing, displaying for the purpose of assignment or leasing, exporting or importing goods which imitate the configuration (excluding configuration that is indispensable for ensuring the function of said goods) of another person's goods;
- acts of acquiring a trade secret by theft, fraud, duress or other wrongful means (hereinafter referred to as "acts of wrongful acquisition"), or the act of using or disclosing a trade secret so acquired (including the act of disclosing such trade secret in confidence to a specific person or persons; the same shall apply hereinafter);

234 Unfair Competition Prevention Act 1993 - Act No.47 of 1993.

- acts of acquiring a trade secret with the knowledge that such trade secret has been acquired through acts of wrongful acquisition or without the knowledge of such matter due to gross negligence, or acts of using or disclosing a trade secret so acquired;
- acts of using or disclosing a trade secret after becoming aware or not becoming aware of such matter due to gross negligence, subsequent to its acquisition, that such trade secret was acquired through wrongful acquisition
- acts of using or disclosing a trade secret, which has been disclosed by the business operator holding such trade secret (hereinafter referred to as the “holder”), for the purpose of unfair business competition or otherwise acquiring an illicit gain, or causing injury to such holder;
- acts of acquiring a trade secret with the knowledge or, without the knowledge due to gross negligence, that there has been an improper disclosure of such trade secret (which means, in the case prescribed in the preceding item, acts of disclosing a trade secret for the purpose prescribed in said item, or acts of disclosing a trade secret in breach of a legal duty to maintain secrecy; the same shall apply hereinafter) or that such trade secret has been acquired through improper disclosure, or acts of using or disclosing a trade secret so acquired;
- acts of using or disclosing an acquired trade secret after becoming aware or not being aware of such matter due to gross negligence, subsequent to its acquisition, that there has been improper disclosure of such trade secret or that such trade secret has been acquired through improper disclosure;
- acts of assigning, delivering, displaying for the purpose of assignment or delivery, exporting or importing (a) devices (including machines incorporating such devices) having the sole function of enabling the viewing of images or hearing of sounds, the running of programs, or the recording of images, sounds or programs which are restricted by technological restriction measures that are used in business (excluding technological restriction measures used to restrict all but specific persons from viewing images or hearing sounds, running programs, or recording images, sounds or programs), by obstructing the effect of such technological restriction measures, or (b) data storage media or machines on which programs having only such function (including other types of programs combined with such programs) have been recorded, or acts of providing programs having only such function through an electric telecommunication line;

- acts of assigning, delivering, displaying for the purpose of assignment or delivery, exporting or importing to all but specific persons (a) devices (including machines incorporating such devices) having the sole function of enabling the viewing of images or hearing of sounds, the running of programs, or the recording of images, sounds or programs which are restricted by technological restriction measures that are used in business to restrict all but said specific persons from viewing images or hearing sounds, running programs, or recording images, sounds or programs, by obstructing the effect of such technological restriction measures, or (b) data storage media or machines on which programs having only such function (including other types of programs combined with such programs) have been recorded, or the act of providing programs having only such function through an electric telecommunication line;
- acts of acquiring or holding a right to use a domain name(s) that is identical or similar to another person's specific indication of goods or services (which means a name, trade name, trademark, mark, or any other indication of a person's goods or services), or the acts of using any such domain name(s), for the purpose of acquiring an illicit gain or causing injury to another person;
- acts of misrepresenting information on goods or services, or in an advertisement thereof or in a document or correspondence used for a transaction related thereto, in a manner that is likely to mislead the public as to the place of origin, quality, contents, manufacturing process, use or quantity of such goods, or the quality, contents, purpose or quantity of such services, or the act of assigning, delivering, displaying for the purpose of assignment or delivery, exporting, importing or providing through an electric telecommunication line, goods with such an indication or providing services with such an indication;
- acts of making or circulating a false allegation that is injurious to the business reputation of another person in a competitive relationship;
- acts by an agent, representative, or a person who was, within one year of the date of the act, an agent or representative of an owner of a right relating to a trademark (such right shall be limited to a right equivalent to a trademark right; hereinafter simply referred to as a "right" in this item) in a country of the Union established by the Paris Convention or in a Member of the World Trade Organization or in a contracting party to the Trademark Law Treaty, without a legitimate reason and the consent of the owner of such right, using a trademark identical or similar to the trademark relating to such right in respect

of goods or services identical or similar to those relating to such right, or the act of assigning, delivering, displaying for the purpose of assignment or delivery, exporting, importing or providing through an electric telecommunication line goods using such trademark, which are identical or similar to the goods relating to such right, or providing services using such trademark, which are identical or similar to the services relating to such right.

C. THE COMMON-LAW APPROACH

5. *The common law does not recognize a general tort:* English common law does not recognize a general unfair competition tort.²³⁵ Instead, it recognizes torts that cover some of the field, the important ones being passing off²³⁶ and the protection of confidential information.²³⁷

The US approaches unfair competition on a more general basis, in part because of its jurisprudence (including the Supreme Court's opinion in *International News Service v Associated Press* [1918] 248 US 215) and in part because of legislative intervention, both at state and federal level, the latter through the Lanham Act.

MOORGATE TOBACCO CO LTD v PHILIP MORRIS LTD

(1984) 156 CLR 415 (HC)

The phrase 'unfair competition' has been used in judgments and learned writings in at least three distinct ways, namely,

- as a synonym of the doctrine of passing off;
- as a generic name to cover the range of legal and equitable causes of action available to protect a trader against the unlawful trading activities of a competitor particularly, by the misappropriation of knowledge or information; and
- to describe what is claimed to be a new and general cause of action which protects a trader against damage caused either by unfair competition generally or, more he has a quasi-proprietary right.

The first and second of the above uses of the phrase are liable to be misleading in that they may wrongly imply that the relevant action

235 Cf. Andrew D. Murray "A distinct lack of goodwill" [1997] *EIPR* 345; *Australian Broadcasting Corp v Lenah Game Meats Pty Ltd* [2001] 185 HCA 63.

236 For the sake of consistency, the hyphenated "passing-off" is not used.

237 For others see *Douglas & Ors v. Hello! Ltd & Ors* [2007] UKHL 21 (2 May 2007).

or actions are restricted to proceedings against a competitor. The second use is also liable to imply that there exists a unity of underlying principle between different actions when, in truth, there is none. The third use of the phrase is, in an Australian context, simply mistaken in that “unfair competition” does not, in itself, provide a sufficient basis for relief under the law of this country.

E. THE MIXED-LAW APPROACH

6. *The general principles of unfair competition.* In countries with a mixed legal tradition, such as South Africa, unfair competition is regarded as a manifestation of the general delict protected by the Aquilian action but common-law precedents have a significant influence on this part of the law.

DAIMLER CHRYSLER AG v AFINTA MOTOR CORP (PTY) LTD

[2001] 2 All SA 219 (T)

The general principles of the law relating to unlawful competition were settled in *Schultz v Butt* 1986 (3) SA 667 (A). These principles may be summarized as follows:

- As a general rule, every person is entitled freely to carry on his trade or business in competition with his rivals. However, such competition must remain within lawful bounds. If it involves a wrongful interference with another’s rights as a trader, it will be unlawful and will constitute an injury for which the Aquilian action will lie if it directly results in loss.
- In order to succeed in an action based on unlawful competition, the plaintiff must establish all the requisites of Aquilian liability, including proof that the defendant has committed an unlawful act.
- Unlawful acts are not limited to acts which fall into a category of clearly recognized illegality, such as trading in contravention of an express statutory prohibition; the making of fraudulent misrepresentations by a rival trader as to his own goods; the passing off by a rival trader of his goods or business as being that of his competitor; the publication by a rival trader of injurious falsehoods concerning his competitor’s business; and the employment of physical assaults and intimidation designed to prevent a competitor from pursuing his trade.
- The lawfulness or unlawfulness of an act of competition may be determined by the application of certain criteria which include fairness and honesty in competition (which requires

that regard be had to *boni mores* and the general sense of justice in the community) and questions of public policy which may be of importance in a particular case, such as the importance of the free market and of competition in our economic system.

UNFAIR COMPETITION: PASSING OFF

CHAPTER XV

- A. INTRODUCTION (1-5)
- B. GEOGRAPHICAL INDICATIONS (6-9)
- C. THE DIFFERENCES BETWEEN TRADEMARK INFRINGEMENT AND PASSING OFF (10-13)
- D. GOODWILL, REPUTATION AND LOCATION (14-17)
- E. THE ELEMENTS OF PASSING OFF (18)
- F. MISREPRESENTATION (19-24)
- G. REPUTATION (25-29)
- H. INTENTION TO CONFUSE OR DECEIVE (30-31)
- I. THE TYPICAL CONSUMER (32)
- J. SHAPE AND CONFIGURATION (33-34)
- K. COMMON FIELD OF ACTIVITY (35)
- L. OVERLAPPING (36-37)

A. INTRODUCTION

1. *Examples of passing off:* Passing off is probably the most common form of unfair competition, whether in civil- or common-law jurisdictions. It is known in American jurisprudence as “trade identity unfair competition”. A few Japanese cases will illustrate the matter.

In *McDonald’s* case²³⁸ the defendant used the well-known arched M of McDonalds as part of its trademark. This was not a trademark infringement case because there is no indication that the arched M had been registered as a trademark. The Court found that the defendant’s use of the mark was unfair because the logo was unique to McDonald’s and had been in constant use for a long period. The Court also held that the defendant’s use would cause ordinary customers and consumers to think that the defendant’s business was connected to that of McDonald’s and that there was accordingly a high probability that this would lead to false recognition and confusion.

In the *Amex* case,²³⁹ American Express sought to prevent the use of the mark Amex by the defendant in relation to foreign exchange transactions. American Express never used Amex as a trademark or trade name but everyone associated the name Amex with American Express. The Court upheld the claim. Importantly, it considered the fact that the defendant could not show that it had been using Amex in good faith and without the object of competing unfairly as significant.

The third case to which reference will be made is the *Manpower* case.²⁴⁰ The plaintiff used as the essential part of its trade name the word “Manpower”. The defendant used, as the essential part of its trade name, the term “Woman Power”. The court found that it was likely that customers would believe that there was a trade association between the two firms and that causing such a misunderstanding amounted to unfair competition.

2. *The basis of the action is that the passing off injures the right to goodwill of a business:*

The courts have wavered between two conceptions of a passing off action – as a remedy for the invasion of a quasi-proprietary right in a trade name or trademark, and as a remedy, analogous to the action on the case for deceit, for invasion of the personal right not to be injured by fraudulent competition. The true basis of the action is that

238 Osaka District Court, Oct. 15, 1993.

239 Supreme Court, Dec. 16, 1993.

240 Supreme Court, Oct. 17, 1983.

the passing off injures the right of property in the plaintiff, that right of property being his right to the goodwill of his business.²⁴¹

FLETCHER CHALLENGE LTD v FLETCHER CHALLENGE (PTY) LTD

[1982] FSR 1 [UK]

While in the early stages of the development of the tort of passing off the subject matter thought to require the protection of the law appears to have been regarded as the plaintiffs' goods, it is, I think made clear by the later cases that the object of the law's intervention into the arena of trade or business is the preservation of a trader's, or businessman's, goodwill from appropriation by another trader or businessman.

WILLIAM GRANT AND SONS LTD v. GLEN CATRINE BONDED WAREHOUSE LTD

[1999] ScotCS 58 [Scotland]

Nor is it in dispute that the common law remedy applied to in this case is based on the principle that no man has a right to sell his goods as though they were the goods of another man. The remedy is intended to prevent unfair trading practices. It becomes actionable at the suit of other traders who thereby suffer loss of business or goodwill. The forms that unfair trading takes will alter with the ways in which trade is carried on and business reputation and goodwill acquired. The concept of goodwill is in law a broad one which is perhaps best expressed in words used by Lord Macnaghten in *Inland Revenue Commissioners v Muller and Companies Margarine Ltd* 1901 AC 217 as being "the benefit and advantage of the good name, reputation, and connection of a business. It is the attractive force which brings in custom."

There are two types of passing off, namely the classic form and the extended form.

3. Classic passing off:

"Classic passing off protects the badge of origin function of a mark [or a get-up], thus consumers must associate the disputed mark [or get-up] with the plaintiff. This association is called goodwill: it is a distinct reputation in the mark that distinguishes the product as the plaintiff's product.

241 From *Salmond on Torts* quoted with approval in *Ciba-Geigy Canada v Apotex Inc* 1992 CanLII 33 (SCC).

Passing off requires damage. This can be diversion of trade or dilution of goodwill. Diversion of trade occurs when consumers buy the defendant's product believing it is the plaintiff's. Dilution of goodwill occurs when consumers who buy the defendant's product believing it is the plaintiff's are so disappointed with the product that the plaintiff's goodwill loses value."²⁴²

WILLIAMS t/a JENIFER WILLIAMS v LIFE LINE

1996 (3) SA 408 (A) [South Africa]

Passing off is a species of wrongful competition in trade or business. In its classic form it usually consists in A representing, either expressly or impliedly (but almost invariably by the latter means), that the goods or services marketed by him emanate in the course of business from B or that there is an association between such goods or services and the business conducted by B. Such conduct is treated by the law as being wrongful because it results, or is calculated to result, in the improper filching of another's trade and/or in an improper infringement of his goodwill and/or causing injury to that other's trade reputation.

Such a representation may be made impliedly by A adopting a trade name or a get-up or mark for his goods which so resembles B's name or get-up or mark as to lead the public to be confused or to be deceived into thinking that A's goods or services emanate from B or that there is the association between them referred to above.

4. *Extended passing off:*

"Extended passing off protects goodwill associated with descriptive and geographical terms. It allows a class of traders to prevent their rivals from incorrectly applying a descriptive term which the plaintiffs apply correctly.²⁴³ Extended passing off goodwill requires clearly identified distinctive and recognizable characteristics associated with the product.²⁴⁴ The goodwill is shared by the traders in the class. Extended passing off is not protection of a mark as a badge of origin, it ensures correct application of the descriptive term.

To succeed in extended passing off the plaintiff's goodwill must be damaged by the defendant's incorrect application of the term.

242 Katherine Saunders *"Choccosuisee – the new 'extended extended' passing off"* [2001] VUWLR 13.

243 Cf. *J Bollinger v The Costa Brava Wine Co Ltd* (No 1) [1960] Ch 262, [1960] RPC 16 and (NO 2) [1961] 1 WLR 277, [1961] RPC 116 [UK].

244 Cf. *Erwen Warnick BV v Townend & Sons (Hull) Ltd* [1979] AC 731 (HL) [Advocaat].

Traders cannot use extended passing off to prevent rivals from applying the descriptive term correctly because this would not damage their goodwill.

Extended passing off differs from classic passing off in two key respects. First, as a misrepresentation of origin is not required [as] it protects traders as a class rather than as individuals. Second, it protects descriptive terms. This does not give monopoly rights in the descriptive term because only incorrect application of the term can be prevented.”²⁴⁵

5. *The difference between the classic and the extended forms described:*

CHOCOSUISSE UNION v CADBURY LTD

[1997] EWHC Patents 360

The facts: The dispute between the parties arose out of the introduction by Cadbury of a new chocolate bar under the name SWISS CHALET. The words SWISS CHALET appeared on the package sleeve in large gold-rimmed red letters, with a picture of a snow-capped mountain – plainly intended to be identified as the Matterhorn – and an alpine chalet in the valley below. The package sleeve bore the word CADBURY in the familiar script format; and the familiar Cadbury “glass and a half” logo to indicate milk chocolate. The chocolate was neither made in Switzerland nor was it made according to the typical Swiss method.

The court in the first instance found that Cadbury had been passing off its chocolate as of Swiss origin and that this infringed the rights of Swiss-based manufacturers of chocolate who had played a major role over the years in the development of the art and technology of chocolate making. An injunction was granted and the judgment upheld on appeal.²⁴⁶

Laddie J:

(a) [*The classic form requires goodwill*]

The type of action of which *Perry v Truefitt and Spalding v Gamage* are examples were described by Lord Diplock in *Advokaat*²⁴⁷ as the ‘classic form’ of passing off. To succeed in this, the plaintiff has to prove that he has built up the necessary goodwill by his own endeavors or that he has acquired it from a predecessor who had

245 Katherine Saunders “Choccosuisse – the new ‘extended extended’ passing off” [2001] VUWLR 13.

246 *Chocossuisse Union v Cadbury Ltd* [1999] EWCA Civ 856; [1999] RPC 826 (CA).

247 *Erwen Warnick BV v Townend & Sons (Hull) Ltd* [1979] AC 731 (HL).

done so. He can not succeed if he has just entered the market and not built up the necessary goodwill.

(b) [*The owner has a freedom of action*]

Furthermore the owner of the goodwill protected by a classic passing off action can do what he pleases with the mark. He can raise or lower the standards of his goods or products, change the location of manufacture, change the ingredients he uses and, if he wants, decide to use the mark or name on an entirely different range of goods or services, as long as this will not lead to a collision with some other trader who already uses the same or a similar name or mark in relation to the new line of business.

(c) [*No monopoly in descriptive words*]

However there are limits on the ability of a trader to acquire a protectable goodwill in a mark or name. In particular, on public policy grounds the courts will be most reluctant to allow him to obtain a monopoly in descriptive words. Thus it is very difficult to succeed in a classic passing off action where the mark is highly geographical or where it is descriptive of or the name for a particular type of product.

(d) [*The extended form protects descriptive terms*]

The classic form of passing off action is to be contrasted with what Lord Diplock called the extended form of passing off first recognized and applied by Dankwerts J. in the *Champagne*²⁴⁸ case. In the *Champagne* type of case, protection is given to a name or word which has come to mean a particular product rather than a product from a particular trader. Normally it is the perfect and perhaps only adequate term to describe the product. Just as an emulsion of fats and water together with other digestible ingredients derived from a cow is called milk and nothing else, so a sparkling white or rosé wine made in a particular defined area in France by a process of double fermentation in the bottle is called champagne and nothing else. The word is entirely descriptive of the product.

(e) [*The descriptive use in the extended case must be accurate*]

The fact that the extended form of action can, in the correct circumstances, protect descriptive words is of significance for a

248 *J Bollinger v The Costa Brava Wine Co Ltd* (No 1) [1960] Ch 262, [1960] RPC 16 and (No 2) [1961] 1 WLR 277, [1961] RPC 116.

number of reasons. The descriptiveness of the protected name also leads to other differences between this and the classic form of passing off. In the new extended form of the action, no proprietor currently using the name in relation to his goods can prevent any new competitor of his making or selling goods to which the name can accurately be applied and from using the name for that purpose. The current users of the descriptive word can only use their shared interest to prevent others from using it on products for which it is not a proper description or designation.

Furthermore it is not open to any existing user of the protected name to use it on products for which it is not an accurate description or designation. Messrs Taittinger are no more entitled to use the word 'Champagne' on a non-alcoholic cola drink than anyone else.

(f) [*The extended action protects accuracy and exclusivity of the descriptive term*]

What can be protected by this form of action is the accuracy and exclusivity of the descriptive term. This is apparent not only from the passage in *Advocaat* just quoted, but also from the recent decision of the Court of Appeal in the *Elderflower Champagne* case. There the plaintiff, Taittinger, sued a company which was making a non-alcoholic sparkling drink in Surrey which it was selling under the name 'Elderflower Champagne'. The trial judge had held that all the necessary ingredients for a successful passing off action had been made out save for proof of likelihood of substantial damage to the plaintiff. In the Court of Appeal the plaintiff argued that the trial judge had erred because if the defendant continued to call its product 'Elderflower Champagne' the effect would be to demolish the distinctiveness of the word champagne, and that would inevitably damage the goodwill of the champagne houses. [This argument was accepted.]

B. GEOGRAPHICAL INDICATIONS

6. *Geographical indications*: The extended form of passing off has in a sense been absorbed by the requirement of the TRIPS Agreement which requires legislation for the protection of geographical indications. Such legislative provisions may impact on the scope of the extended passing off action, which developed in order to protect these indications against a misrepresentation relating to origin, and replace at least it in part. The TRIPS protection of these indications is statutory and direct and is mentioned here for the sake of convenience because of its relationship to the extended passing off action, which is discussed later.

7. Defining geographical indications: Geographical indications are defined (Art. 22.1) as indications which identify goods as originating in the territory of a country, or a region or locality in that territory, where a given quality, reputation or other characteristic of the good is essentially attributable to its geographical origin.

There is much dispute between countries about what is a geographical indication and what is not. For instance, the term “Champagne” for a sparkling wine is considered in many countries as an indication of origin meaning that only wine of that kind produced within the Champagne area in France may use the appellation. However, others, such as the USA, regard the term as generic to cover sparkling wines of whatever origin. Bilateral trade agreements have forced smaller countries to recognize many names as geographical indications that for decades (if not centuries) have been used generically. One such example is South African sherry: sherry is all of a sudden a product of Spain and Spain alone, ignoring history and fact.

8. The required protection: Basically, the following protection for geographical indications is required (Art. 22):

- preventing the use of any means in the designation or presentation of a good that indicates or suggests that the good in question originates in a geographical area other than the true place of origin in a manner which misleads the public as to the geographical origin of the good;
- preventing any use which constitutes an act of unfair competition.

9. Some trademark statutes provide for the registration of geographical indications as collective trademarks. These are marks capable of distinguishing, in the course of trade, goods or services of persons who are members of any association from goods or services of persons who are not members. If registered, the trademark holder need not prove a reputation in order to enforce its registered rights.

C. THE DIFFERENCES BETWEEN TRADEMARK INFRINGEMENT AND PASSING OFF

10. The expansion of passing off: Passing off is no longer anchored to a trademark or trade name, but encompasses other material such as slogans or visual images, provided always that this material has become part of the plaintiff's “goodwill”.²⁴⁹

249 For an extended application of the principles see the *Chocosuisse Union v Cadbury Ltd* cases mentioned earlier.

CAMPOMAR SOCIEDAD LTA v NIKE INTERNATIONAL LTD

[2000] HCA 12 [Australia]

The tort of passing off is but one of the greatly differing contexts in which the courts have been called on to define and identify the nature of goodwill. The injuries against which the goodwill is protected in a passing off suit are not limited to diversion of sales by any representations that the goods or services of the defendant are those of the plaintiff. In *Spalding* itself, the misrepresentation was that one class of the plaintiff's goods was another class. In more recent times there has been development both in the nature of the "goodwill" involved in passing off actions and in the range of conduct which will be restrained. In *Moorgate Tobacco*, Deane J spoke with evident approval of:

"the adaptation of the traditional doctrine of passing off to meet new circumstances involving the deceptive or confusing use of names, descriptive terms or other indicia to persuade purchasers or customers to believe that goods or services have an association, quality or endorsement which belongs or would belong to goods or services of, or associated with, another or others."

- 11. Misrepresentation:** The basis of a passing off action is a misrepresentation but trademark infringement does not require any misrepresentation.

FISONS plc v NORTON HEALTHCARE LTD

[1994] FSR 745 (Ch)

When considering infringement of a registered trademark, it is important to bear in mind the difference between the test for infringement and that in a passing off action. In a passing off action, the court looks to see whether there is a misrepresentation; whereas the Trademarks Act gives to the proprietor an exclusive right to the use of the mark which will be infringed in the case of identical marks and can be in the case of similar marks even though no misrepresentation actually takes place.²⁵⁰

- 12. Reputation and its date:** In the case of passing off, the plaintiff must prove a reputation in the mark or get-up and the reputation of the claimant must exist at the time the respondent enters the market. In trademark infringement proceedings, the plaintiff's reputation is irrelevant.

250 See also *Playboy Enterprises v Bharat Malik* 2001 PTC 328 [India].

13. *Basis of comparison:* Infringement proceedings under a Trademark Act are directed at a comparison between the registered trademark as such and the allegedly offending mark as such, whereas, in passing off proceedings, the comparison is between the whole get-up of the goods as marketed by the plaintiff and the whole get-up of the defendant's goods.

The differences can best be illustrated by two cases between the same parties in the same court. In the first, mentioned in a previous chapter, the court found that there was no infringement of the trademark ROMANY CREAMS by the use of ROMANTIC DREAMS, in spite of the similar trade dress. The second, dealing with TENNIS biscuits, concerned trade dress and the court found infringement.

NATIONAL BRANDS LTD v BLUE LION MANUFACTURING (PTY) LTD

[2001] ZASCA 17 [South Africa]

It is important to bear in mind, particularly in a case like the present one that the likelihood (or otherwise) of deception or confusion must be attributable to the resemblance (or otherwise) of the marks themselves and not to extraneous matter. Similarities in the goods themselves or in the form in which they are presented might form the basis for an action for passing off, but that is not what is before us, and for present purposes they must be disregarded.

BLUE LION MANUFACTURING (PTY) LTD v NATIONAL BRANDS LTD

[2001] ZASCA 62 [South Africa]

The law of passing off is not designed to grant monopolies in successful get-ups. A certain measure of copying is permissible. But the moment a party copies he is in danger and he escapes liability only if he makes it "perfectly clear" to the public that the articles which he is selling are not the other manufacturer's, but his own articles, so that there is no probability of any ordinary purchaser being deceived.

D. GOODWILL, REPUTATION AND LOCATION

14. *Goodwill and reputation:* The general rule relating to location in the UK and some other common-law jurisdictions is that the business of the plaintiff must consist of or include selling in the jurisdiction a class of goods to which the particular trade name applies. This is based on what some regard as a confusion between goodwill and reputation.

PONTIAC MARINA PTE LTD v CDL HOTELS INTERNATIONAL LTD

[1998] FSR 839 [Singapore]

There appears to be considerable diversity of opinion as to the nature of the right, the invasion of which is the subject of what are known as passing off actions. The more general opinion appears to be that the right is a right of property. This view naturally demands an answer to the question – property in what? Some authorities say property in the mark, name, or getup improperly used by the defendant. Others say, property in the business or goodwill likely to be injured by the misrepresentation. Lord Herschell in *Reddaway v. Banham* (LR (1896) AC 139) expressly dissents from the former view; and if the right invaded is a right of property at all, there are, I think strong reasons for preferring the latter view.

The terms goodwill and reputation have often been used interchangeably, giving rise to some confusion. Goodwill does not exist on its own and it attaches to a business. On the other hand, reputation may, and often does, exist without any supporting business. Thus, having a widespread reputation in a particular place does not necessarily mean that the trader has a goodwill in his business.

Pre-business activities can generate goodwill. This is a commonsense approach and is in line with commercial reality where promoters of businesses usually embark on massive advertising campaigns before the commencement of trading to familiarize the public with the service or product. In every case, whether the pre-trading activity suffices in generating goodwill is a question of fact and depends on the nature and intensity of the activity in question. Heavy advertising will be adequate. On the other hand, mere preparations for trading will not.

15. *The hard-line approach:**STAR INDUSTRIAL CO LTD v YAP KWEE KOR*

[1976] FSR 256 (PC) [The case emanated from Singapore.]

A passing off action is a remedy for the invasion of a right of property not in the mark, name or get-up improperly used, but in the business or goodwill likely to be injured by the misrepresentation made by passing off one person's goods as the goods of another. Goodwill, as the subject of proprietary rights, is incapable of subsisting by itself. It has no independent existence apart from the business to which it is

attached. It is local in character and divisible; if the business is carried on in several countries a separate goodwill attaches to it in each.

16. *The soft-line approach:* The hard-line approach is no longer followed strictly in most common-law countries including Australia, Canada, Hong Kong (China),²⁵¹ India,²⁵² New Zealand and South Africa.

CATERHAM CAR SALES v BIRKIN CARS (PTY) LTD

1998 (3) SA 938 (SCA)

The essence of an action for passing off is to protect a business against a misrepresentation of a particular kind, namely that the business, goods or services of the representor is that of the plaintiff or is associated therewith. In other words, it protects against deception as to a trade source or to a business connection.

Misrepresentations of this kind can be committed only in relation to a business that has goodwill or a drawing power. Goodwill is the totality of attributes that lure or entice clients or potential clients to support a particular business. The components of goodwill are many and diverse. Well recognized are the locality and the personality of the driving force behind the business, business licenses, agreements such as restraints of trade and reputation. These components are not necessarily all present in the goodwill of any particular business.

The only component of goodwill of a business that can be damaged by means of a passing off is its reputation and it is for this reason that the first requirement for a successful passing off action is proof of the relevant reputation. Misrepresentations concerning other components of goodwill are protected by other causes of action such as claims for injurious falsehoods. It is thus incorrect to equate goodwill with reputation (or vice versa) or to suggest that the “need for some reputation or secondary meaning to be shown is not a principle or rule of law”. If the protection of the reputation of a business is the only or main concern of the remedy, why is it necessary to localize goodwill for purposes of passing off?

In general terms, it appears to me to be whether the plaintiff has, in a practical and business sense, a sufficient reputation amongst a substantial number of persons who are either clients or potential clients of his business. As far as the “location” of reputation is concerned,

251 *Tan-Ichi Company Ltd v Jancar Ltd* [1990] F.S.R. 151 (HC).

252 *William Grant & Sons Ltd v McDowell & Co Ltd* [1994] F.S.R. 690 [India]; *Jolen Inc v Doctor & Co* 2002 (25) PTC 29 (Delhi); *Ziff-Davis v Jain* 1998 PCT (18) 739 (Delhi).

it must subsist where the misrepresentation complained of causes actual or potential damage to the drawing power of the plaintiff's business. Otherwise the misrepresentation would be made in the air and be without any consequences. The locality of the plaintiff's business is not hereby rendered irrelevant. Obviously, it must be an important consideration in determining whether the plaintiff has potential clients and whether the alleged misrepresentation causes his business any harm. Likewise, the extent of a business's reputation and the scope of its activities are relevant to the probability of deception and to damages – the smaller the reputation, the smaller the likelihood of deception and of damage, and vice versa.

ORKIN EXTERMINATING CO v PESTCO CO OF CANADA

80 CPR (2d) 153, 11 D.L.R. (4th) 84

Virtually no words have a single fixed meaning, particularly goodwill. In this kind of case I think that the main consideration should be the likelihood of confusion with consequential injury to the plaintiff. Generally, where there is such confusion there is goodwill deserving of protection.

WHIRLPOOL Trade Mark

[1997] F.S.R. 905 High Court of Delhi²⁵³

The knowledge and awareness of a trade mark in respect of the goods of a trader is not necessarily restricted only to the people of the country where such goods are freely available but the knowledge and awareness of the same reaches even the shores of those countries where such goods have not been marketed. When a product is launched and hits the market in one country, cognizance of the fact is also taken by people in other countries at almost the same time by becoming acquainted with it through advertisements in newspapers, magazines, television, video films, cinema, etc., even though there may not be availability of the product in those countries because of import restrictions or other factors. In today's world it cannot be said that a product and the trade mark under which it is sold abroad, does not generate a reputation or goodwill in countries where it is not available. The knowledge and awareness of it and its critical evaluation and appraisal travels beyond the confines of the geographical area in which it is sold. This had been made possible by the development of communication systems which transmit and disseminate the information as soon as it is sent or beamed from one

253 An appeal against this judgment was dismissed.

place to another. Satellite television is a major contributor to the information explosion. Dissemination of knowledge of a trade mark in respect of a product through advertisements in the media amounts to use of the trade mark whether or not the advertisement is coupled with the actual existence of relevant products on the market.

17. *Internet use is not necessarily enough to create goodwill:*

NOVELTY PTE LTD v AMANRESORTS LTD

[2009] SGCA 13

This point is significant for, as Laddie J incisively noted in *Sutherland v V2 Music Ltd* [2002] EMLR 28 at [22]:

“The law of passing off protects the goodwill of a small business as much as [the goodwill of] the large, but it will not intervene to protect the goodwill which any reasonable person would consider trivial.”

It must be noted that although the Internet has the potential to be used for giving goods, services and businesses instant exposure across the entire world, it does not follow that any small, dinky business can set up a website and then claim that it has gained worldwide recognition. The Internet’s power of exposure is only a *potential* power.

This issue was given some consideration in *800-FLOWERS Trade Mark* [2000] EWHC 131; [2000] FSR 697 which concerned a dispute over the registration of a service mark. In that case, an application to register a name as a service mark was objected to on, *inter alia*, the ground that the name had not been used in the UK. The applicant sought to counter this argument by relying on its use of that name for its website. Jacob J observed very sensibly:

“Mr Hobbs [counsel for the applicant] submitted that any use of a trade mark on any website, wherever the owner of the site was, was potentially a trade mark infringement anywhere in the world because website use is in an omnipresent cyberspace: that placing a trade mark on a website was “putting a tentacle” into the computer user’s premises. I questioned this. For trade mark laws to intrude where a website owner is not intending to address the world but only a local clientele and where anyone seeing the site would so understand him would be absurd. So I think that the mere fact that websites can be accessed

anywhere in the world does not mean, for trade mark purposes, that the law should regard them as being used everywhere in the world.”

The requirement of “use” of a trade mark in a jurisdiction (in the context of trade mark law) is, of course, pegged at a higher standard than the standard which applies when determining whether goodwill exists in a name (in the latter context, exposure, as opposed to use, of the name in question is the relevant criterion). But, the principle that putting a name up on the Internet does not translate into instant global presence of that name is applicable *vis-à-vis* the analysis of goodwill in passing off actions.

E. THE ELEMENTS OF PASSING OFF

18. *The elements of passing off*:²⁵⁴

WARNINK v TOWNEND

[1980] RPC 31

My Lords, *Spalding v Gamage* and the later cases make it possible to identify five characteristics which must be present in order to create a valid cause of action for passing off:

- a misrepresentation
- made by a trader in the course of trade
- to prospective customers of his or ultimate consumers of goods or services supplied by him,
- which is calculated to injure the business or goodwill of another trader (in the sense that this is a reasonably foreseeable consequence), and
- which causes actual damage to a business or goodwill of the trader by whom the action is brought or (in a *quia timet* action) will probably do so.’

F. MISREPRESENTATION

19. *Misrepresentation*: As mentioned, the basis of the cause of action is misrepresentation giving rise to confusion.

²⁵⁴ Scotland: *William Grant and Sons Ltd v Glen Catrine Bonded Warehouse Ltd* [1999] ScotCS 58; Australia: *Fletcher Challenge Ltd v Fletcher Challenge (Pty) Ltd* [1982] FSR 1; Canada: *Kirkbi Ag v Ritvik Holdings Inc* 2005 SCC 65.

A G SPALDING & BROS v A W GAMAGE LTD

(1915) 32 RPC 273 [UK]

My Lords, the basis of a passing off action being a false representation by the defendant, it must be proved in each case as a fact that the false representation was made. It may, of course, have been made in express words, but cases of express misrepresentation of this sort are rare. The more common case is, where the representation is implied in the use or imitation of a mark, trade name, or get-up with which the goods of another are associated in the minds of the public, or of a particular class of the public. In such cases the point to be decided is whether, having regard to all the circumstances of the case, the use by the defendant in connection with the goods of the mark, name, or get-up in question impliedly represents such goods to be the goods of the plaintiff, or the goods of the plaintiff of a particular class or quality, or, as it is sometimes put, whether the defendant's use of such mark, name, or get-up is calculated to deceive. It would, however, be impossible to enumerate or classify all the possible ways in which a man may make the false representation relied on.

20. *Confusion and causation:* Confusion, *per se*, is not actionable.²⁵⁵ The confusion must be caused by the defendant's misrepresentation.

Where the public is familiar with the plaintiff's goods or services of a particular kind, substantial numbers of persons may assume that competing goods or services offered by a newcomer are the goods or services of the plaintiff with whom they have hitherto been familiar, but confusion arising merely from this cause is to be disregarded.²⁵⁶

MARENGO v DAILY SKETCH and SUNDAY GRAPHIC LTD

[1992] FSR 1 [UK]

No one is entitled to be protected against confusion as such. Confusion may result from one collusion of two independent rights or liberties, and where this is the case, neither party can complain; they must put up with the results of the confusion as one of the misfortunes which occur in life.²⁵⁷

²⁵⁵ Also *County Sound v Ocean Sound Ltd* [1991] FSR 367.

²⁵⁶ *Halsbury's Laws of England* 4ed vol 48 par 153 quoted with approval in *Hoechst Pharmaceuticals (Pty) Ltd v The Beauty Box (Pty) Ltd* 1987 (2) SA 600 (A).

²⁵⁷ On appeal: (1948) 65 RPC 242 (HL). The judgment quoted was reported belatedly.

21. *The distinction between confusion and deception:*

PHONES4U v PHONE4U.CO.UK

[2006] EWCA Civ 244 [UK]

Sometimes a distinction is drawn between “mere confusion” which is not enough, and “deception”, which is. I described the difference as “elusive” in *Reed Executive v Reed Business Information* [2004] RPC 767 at 797. I said this:

“Once the position strays into misleading a substantial number of people (going from ‘I wonder if there is a connection’ to ‘I assume there is a connection’) there will be passing off, whether the use is as a business name or a trade mark on goods.”

This of course is a question of degree – there will be some mere wonderers and some assumers – there will normally (see below) be passing off if there is a substantial number of the latter even if there is also a substantial number of the former.

The current (2005) edition of *Kerly* contains a discussion of the distinction at paragraphs 15-043 – 15-045. It is suggested that:

“The real distinction between mere confusion and deception lies in their causative effects. Mere confusion has no causative effect (other than to confuse lawyers and their clients) whereas, if in answer to the question: ‘what moves the public to buy?’, the insignia complained of is identified, then it is a case of deception.”

Although correct as far as it goes, I do not endorse that as a complete statement of the position. Clearly if the public are induced to buy by mistaking the insignia of B for that which they know to be that of A, there is deception. But there are other cases too. A more complete test would be whether what is said to be deception rather than mere confusion is really likely to be damaging to the claimant’s goodwill or divert trade from him. I emphasize the word “really”.

In this discussion of “deception/confusion” it should be remembered that there are cases where what at first sight may look like deception and indeed will involve deception, is nonetheless justified in law. I have in mind cases of honest concurrent use and very descriptive marks. Sometimes such cases are described as ‘mere confusion’ but they are not really – they are cases of tolerated deception or a tolerated level of deception.

An example of the former is the old case of *Dent v Turpin* (1861) 2 J&H 139. Father Dent had two clock shops, one in the City, the other in the West End. He bequeathed one to each son – which resulted in two clock businesses each called Dent. Neither could stop the other; each could stop a third party (a villain rather appropriately named Turpin) from using “Dent” for such a business. A member of the public who only knew of one of the two businesses would assume that the other was part of it – he would be deceived. Yet passing off would not lie for one son against the other because of the positive right of the other business. However it would lie against the third party usurper.

An example of the latter is *Office Cleaning Services v Westminster Window and General Cleaners* (1946) 63 RPC 39. The differences between “Office Cleaning Services Ltd” and “Office Cleaning Association”, even though the former was well-known, were held to be enough to avoid passing off.

In short, therefore, where the ‘badge’ of the plaintiff is descriptive, cases of “mere confusion” caused by the use of a very similar description will not count. A certain amount of deception is to be tolerated for policy reasons – one calls it “mere confusion”.

S\$1.99 PRIVATE LTD v LIFESTYLE 1.99 PRIVATE LTD

[2001] FSR 10 [Singapore]

We do not think that the respondents have shown that there has been any misrepresentation. We noted the evidence relating to the survey results show that there were members of the public who thought the two businesses were related. But in the nature of things some such misconception would be inevitable when you have two businesses adopting a similar descriptive term as a part of their names. Given a little time the public will be able to distinguish, now that the two businesses are operating side-by-side. Otherwise, it would amount to granting a monopoly to the person who happens to use that descriptive term first.

22. *The risk of deception must be real:*

PONTIAC MARINA v CDL HOTELS INTERNATIONAL LTD

[1998] FSR 839 [Singapore]

The instant case is a *quia timet* action where the respondents are seeking to prevent an apprehended misrepresentation by the

appellants. In such an action the test is whether there is a real risk that the defendant's representation would deceive a substantial number of persons of the relevant section of the public into believing either that the goods or services of the defendant are those of the plaintiff or that there is a business connection between the plaintiff and the defendant in relation to the goods or services provided by them.

23. *Onus:* The plaintiff must allege and prove a misrepresentation by the defendant. The test applied to determine whether a misrepresentation amounts to passing off is whether there is a reasonable likelihood that members of the public may be confused into believing that the business of one person is, or is connected with, that of another. Such representation must be false and unauthorized. The typical case of passing off is where the defendant uses, adopts or imitates the trade name or get-up of the plaintiff's business, goods or services.

24. *The factors to consider in determining misrepresentation:*

CADILA HEALTH CARE v CADILA PHARMACEUTICALS

AIR 2001 SC 1952 [India]

Broadly stated, in an action for passing off on the basis of unregistered trade mark, generally for deciding the question of deceptive similarity the following factors [are] to be considered. [Weight must] be given to each of the aforesaid factors depends upon facts of each case and the same [weight] cannot be given to each factor in every case.

- The nature of the marks i.e. whether the marks are word marks or label marks or composite marks, i.e. both words and label works.
- The degree of [resemblance] between the marks, phonetically similar and hence similar in idea.
- The nature of the goods in respect of which they are used as trademarks.
- The similarity in the nature, character and performance of the goods of the rival traders.
- The class of purchasers who are likely to buy the goods bearing the marks they require, on their education and intelligence and a degree of care they are likely to exercise in purchasing and/or using the goods.
- The mode of purchasing the goods or placing orders for the goods, and
- Any other surrounding circumstances which may be relevant in the extent of dissimilarity between the competing marks.

G. REPUTATION

25. Proof of reputation: It is necessary to allege and prove that the trade name, trademark, get-up or service mark was known in the market and that the plaintiff's goods, business or service acquired a public reputation or became distinctive from other, similar goods, businesses or services. Consequently, where a trader uses a word in its ordinary meaning in connection with her or his goods or business, or uses a trade or service mark or trade name, which is a descriptive term, it must be proved that, through use, such word acquired a secondary meaning and designates the plaintiff's goods, services or business. Where, however, a trader uses a fancy or invented name, it is difficult to avoid an inference of passing off if a rival uses that name.

26. When reputation must exist: The reputation relied upon must have been in existence at the time the defendant entered the market, in other words, a plaintiff cannot rely on a reputation that overtook the business of the defendant.²⁵⁸ It must also exist when the misrepresentation is committed, and the plaintiff cannot rely on a past reputation.²⁵⁹

27. Reputation is a question of fact:

PARKER-KNOLL LIMITED V KNOLL INTERNATIONAL LIMITED

1962 RPC 278 (HL) [UK]

It is a question of fact whether it is proved that a name [or get-up] has acquired a secondary meaning so that it denotes or has come to mean goods made by a particular person and not goods made by any other person even though such person may have the same name.

If it is proved on behalf of a plaintiff that a name [or get-up] has acquired such a secondary meaning, then it is a question for the court whether a defendant, whatever maybe his intention, is so describing his goods that there is a likelihood that a substantial section of the purchasing public will be misled into believing that his goods are the goods of the plaintiff. In arriving at a decision the court must not surrender in favor of any witness its own independent judgment.

²⁵⁸ *Anheuser-Busch Inc v Budejovicky Budvar NP* [1984] FSR 413 (CA).

²⁵⁹ *Ad-Lib Club v Granville* [1972] RPC 673.

28. Establishing distinctiveness:

ADCOCK-INGRAM PRODUCTS LTD v BEECHAM SA (PTY) LTD

1977 (4) SA 434 (W) [South Africa]

In the case of an indirect representation, the plaintiff must prove in the first instance that the defendant has used or is using in connection with his own goods a name, mark, sign or get-up which has become distinctive

“in the sense that by the use of (the plaintiff’s) name or mark, etc., in relation to goods they are regarded by a substantial number of members of the public or in the trade, as coming from a particular source known or unknown”

(Halsbury *Laws of England* 3ed vol 38 p 597). In other words, the plaintiff must prove that the feature of his product on which he relies has acquired a meaning or significance, so that it indicates a single source for goods on which that feature is used.

It is not necessary that the get-up as a whole should be distinctive, for a part of the get-up may be shown to be so identified with the plaintiff’s goods that its use for similar goods is calculated to pass them off as his. So, in *John Haig & Co Ltd v Forth Blending Co Ltd* [1953] RPC 259 (Ct S), it was said that:

“A container such as a bottle may be part of the get-up of goods of a trader if it is of a peculiar shape which catches the eye and it is retained in the memory of the ordinary purchaser, and it is associated in the mind of the purchasing public with the goods of that particular trader alone and of no other.”

In that case it was held that the peculiarly shaped three pinch decanter or “dimple” bottle had become associated with the Dimple Haig Whisky blended and marketed by the petitioning company. Again, in *Coca-Cola Co v Barr AG and Co Ltd* [1961] RPC 387, it was considered that the petitioners had made out a prima facie case that their bottle (which had a waist, carried no label and had fluting) was distinctive of their product Coca-Cola.

29. Nature of prior use required to establish goodwill:

JARMAN & PLATT LTD v I BARGET LTD

[1977] FSR 260 (CA)

The plaintiff must show more than mere prior use by him of the particular get-up. He must show that the get-up has become in the mind of the public distinctive of one particular trader and no other trader; so that the get-up has come to mean, to the public, a product coming from a particular commercial source. They, the public, do not have to know the name of the trader. But it has to be shown that the product is, in the minds of individual members of the public who are buyers or potential buyers of the goods, the product of that manufacturer 'with whom I have become familiar'. That is the test. The property arising from that reputation must be actual, proven goodwill in the mind of the public towards the owner of the reputation. The ownership of that reputation must be proved.

A manufacturer may be responsible for 90 per cent of the sales to the public of a particular type or style of goods. That does not, in itself, begin to prove that a substantial number of the members of the public who buy those goods do so because they know of, or have any interest in, the particular source of the goods; or that they are attracted to buy those goods because of their knowledge or belief that they emanate from a particular source – a particular maker.

H. INTENTION TO CONFUSE OR DECEIVE

30. *Calculated to deceive or confuse:* It is necessary to establish that the defendant's get-up or trade name was calculated or likely to deceive or confuse the ordinary customer and, thus, to cause confusion and damage to the goodwill of the plaintiff's business by, for example, diverting customers from the plaintiff's business or products to that of the defendant. It is not necessary for a trader seeking relief to prove that anyone has actually been deceived or confused.

31. *Innocent passing off is possible but unlikely:*

BLUE LION MANUFACTURING (PTY) LTD v NATIONAL BRANDS LTD

[2001] ZASCA 62 [South Africa]

Although innocent passing off is possible, I think Wessels CJ was right when he said:

“Here [in the field of passing off by adopting a get-up] as a rule the element of *dolus* [wrongful intent] prevails, for the get-up is seldom, if ever, accidental: it is generally the result of calculated imitation.”

Now, while it is perfectly true that in the end the question is whether there is a passing off, an allegation of fraud is not so lightly flicked aside. Our courts, like the English courts, have frequently pointed to the pertinence of the enquiry.

HARRODS LTD v HARRODIAN SCHOOL LTD

[1996] RPC 697 (CA):

Deception is the gist of the tort of passing off, but it is not necessary for a plaintiff to establish that the defendant consciously intended to deceive the public if that is the probable result of his conduct. Nevertheless, the question why the defendant chose to adopt a particular name or get up is always highly relevant. It is a question which falls to be asked and answered. If it is shown that the defendant deliberately sought to take the benefit of the plaintiff's goodwill for himself, the court will not be astute to say that he cannot succeed in doing what which he is straining every nerve to do.

I. THE TYPICAL CONSUMER

32. In considering the likelihood of confusion or deception regard should be had to the similarities rather than to the dissimilarities between the two get-ups and whether the typical consumer may be deceived or confuse. The principles are no different from those that apply to trademark infringement.

CADILA HEALTH CARE v CADILA PHARMACEUTICALS

AIR 2001 SC 1952 [India]

[Pharmaceutical] products will be purchased by both villagers and townfolk, literate as well as illiterate and the question has to be approached from the point of view of a man of average intelligence and imperfect recollection. A trade may relate to goods largely sold to illiterate or badly educated persons. The purchaser in India cannot be equated with a purchaser of goods in England.

In a country like India, where there is no single common language, a large percentage of population is illiterate and a small fraction of people know English, then to apply the principles of English law

regarding dissimilarity of the marks or the customer knowing about the distinguishing characteristics of the plaintiff's goods seems to overlook the ground realities in India.

RECKITT & COLMAN SA v S C JOHNSON & SON

1993 (2) SA 307 (A) [South Africa]

A rule of long standing requires that the class of persons who are likely to be the purchasers of the goods in question must be taken into account in determining whether there is a likelihood of confusion or deception. In *American Chewing Products Corporation v American Chicle Company* 1948 (2) SA 736 (A) regard was had to the fact that addicts of the gum chewing habit included a large number of children and illiterates and in *William Edge and Sons Ltd v William Nicolls & Sons Ltd* [1911] AC 693 the probability of confusion amongst illiterate washerwomen, who were said to be the main purchasers, was considered.

It is not surprising that the racial and cultural diversity to be found in this country has been referred to in the evidence. It was pointed out that blacks and whites present different customer profiles and that there are many members of the public who are, in differing degrees, illiterate. One of the greatest problems facing illiterate persons is their inability to cope as consumers.

The problem in this case is that it is not possible to classify the consumers of these products because they are purchased by members of all sectors of the population irrespective of race, or level of literacy or sophistication. The notional consumer is therefore as elusive as the reasonable man and it is unlikely that he will be found on any suburban bus. The fact of the matter remains that at least some members of the purchasing public are illiterate and that fact cannot be ignored. But, as was pointed out by counsel for the respondent, the fact that a person is illiterate does not mean that he lacks cognitive powers. It may be that the typical illiterate purchaser is a more careful purchaser because he has adapted to his social disability and cannot afford to err. However, we do not know from the evidence how illiterate people distinguish between goods with different names (assuming all other things to be equal). Speaking for myself, I am unable to state whether an illiterate person does or does not ordinarily regard a word as a picture.

J. SHAPE AND CONFIGURATION

33. *Shape and configuration:* A case of passing off may be made out based on the shape or configuration of the article concerned. The use of trademarks or other features may exclude the likelihood of deception or confusion arising from the use of a similar get-up or feature. But this will not necessarily follow from the use of different names. It will always be a factual question.

34. *Meaning of get-up:*

JB WILLIAMS CO v H BRONNLEY & CO LTD

(1909) 26 RPC 765

The get-up of an article means a capricious addition to the article itself: the color, or shape, it may be, of the wrapper, or anything of that kind; but I strongly object to look at anything, that has a value in use, as part of the get-up of the article. Anything, which is in itself useful, appears to me rightly to belong to the article itself. For instance, supposing that a firm had been, say for 20 years, the only firm to sell wooden chairs in which the natural wood was simply varnished, and not painted at all, that would not give them the slightest right to complain of a person putting on the market chairs simply varnished, even though they had been the only persons who had sold them for so long that such chairs might at first be supposed to be their manufacture. The reason is that the newcomer has not in any way imitated the get-up; he has only reproduced the article.

PARKDALE CUSTOM BUILT FURNITURE (PTY) LTD v PUXU (PTY) LTD

(1982) 149 CLR 191

A distinction is drawn between the get-up of goods and the copying of the actual goods. Similarity in get-up may evidence passing off, but (statutory monopoly apart) all are free to copy the goods themselves. [The Court quoted the previous extract and proceeded as follows.]

The distinction between the design of an article and its get-up is clear enough in principle, but oftentimes its application in particular cases will present questions of nicety and difficulty.

A later manufacturer who does no more than exercise his freedom to manufacture and sell goods made in accordance with a design in

the public domain does not mislead or deceive; and if a consumer has an erroneous preconceived belief that the first manufacturer has a monopoly, a false assumption by the consumer as to the source of the later manufacturer's goods is self-induced.

K. COMMON FIELD OF ACTIVITY

35. *Common field of activity is not required:* It is not a requirement that the parties should have been involved in the same field of activity although the fact whether or not they are may be of major consequence.

CAPITAL ESTATE v HOLIDAY INNS INC

1977 (2) SA 916 (A)

The argument is that, unless the name is used in a common field of activity, there can be no real likelihood of members of the public being misled into believing that the shopping centre is the business of the respondents. [The court rejected the argument with reference to English and Australian authorities.]

Whether there is a reasonable likelihood of such confusion arising is, of course, a question of fact which will have to be determined in the light of the circumstances of each case. If the evidence establishes that there is a reasonable likelihood of such confusion arising even if the parties concerned cannot be said to be carrying on their activities in a common field, it is difficult to see how the absence of such a common field can nevertheless constitute a ground for denying relief to an aggrieved party. The absence of a common field of activities is, of course, a factor which one has to take into account when considering the question whether someone's conduct is likely to lead to confusion of the kind mentioned, but the proper weight to be assigned thereto will depend on a consideration of all the relevant facts.

L. OVERLAPPING

36. *Overlapping:* A passing off action is often brought as an alternative or additional claim to a trademark infringement action but this is logically untenable because trademark infringement involves a narrower investigation than passing off.

An act of passing off may overlap with other types of unlawful competition such as contravention of a statutory provision as in a Counterfeit Goods Act,

Merchandise Marks Act or a Trade Descriptions Act. Where that is the case the plaintiff may base the claim in the alternative on a contravention of the relevant statute.

A get-up may also constitute an original artistic work protected in terms of a Copyright Act. If it does, the plaintiff may base the claim on passing off, infringement of copyright or both and may claim the remedies provided for in the Copyright Act.

37. *Limits to overlapping.* One should beware of confusing passing off and the general cause of action of unlawful competition.

PAYEN COMPONENTS SA LTD v BOVIC CC

1995 (4) SA 441 (A)

In my opinion a court should be wary of allowing the sharp outlines of these two established branches of the law of unlawful competition, evolved through long experience, to be fudged by allowing a vague penumbra around the outline. Unlawful competition should not be added as a ragbag and often forlorn final alternative to every trade mark, copyright, design or passing-off action. In most cases it is one of the established categories or nothing.

UNFAIR COMPETITION: CONFIDENTIAL INFORMATION

CHAPTER XVI

- A. BASIS OF PROTECTION AT COMMON LAW (1-3)
- B. MIXED-LAW APPROACH (4)
- C. CIVIL-LAW APPROACH (5)
- D. EMPLOYER-EMPLOYEE RELATIONSHIP (6)
- E. THE PROTECTION OF KNOW-HOW AND TRADE SECRETS (7-8)
- F. USE OF STOCK OF KNOWLEDGE BY EX-EMPLOYEE (9-10)
- G. SPRINGBOARD (11)
- H. REMEDIES (12)

1. *The general common-law approach:* The cause of action is at common law an equitable action and at present it does not only protect confidential information in the commercial sense but also the right to privacy. It is not dependent on the existence of a contractual relationship. The case next cited went on appeal where it was upheld in part. The appeal judgment²⁶⁰ is of major importance but too extensive to quote here.

DOUGLAS v HELLO! LTD

[2003] EWHC 786 (Ch) [UK]

At the broadest level of generality it can be said that equity offers remedies where a breach of an appropriate confidence, personal or commercial, is threatened or has occurred. The jurisdiction in confidence “is based not so much on property or on contract as on a duty to be of good faith”. It is based “on the moral principles of loyalty and fair dealing” [and] there is a public interest in the maintenance of confidences.

2. *The nature of confidential information.*

COCO v A N CLARK (ENGINEERS) LTD

[1969] RPC 41 [UK]

- First, the information itself must have the necessary quality of confidence about it.
- Secondly, that information must have been imparted in circumstances importing an obligation of confidence.
- Thirdly, there must be an unauthorized use of that information to the detriment of the party communicating it.

3. *The cause of action does not require an initial confidential relationship:*

CAMPBELL v MGN LTD

[2004] UKHL 22

This cause of action has now firmly shaken off the limiting constraint of the need for an initial confidential relationship. In doing so it has changed its nature. Now the law imposes a ‘duty of confidence’ whenever a person receives information he knows or ought to know is fairly and reasonably to be regarded as confidential. Even this formulation is awkward. The continuing use of the phrase ‘duty of confidence’ and the description of the information as ‘confidential’ is not altogether

260 For the judgment of the House of Lords on appeal: *Douglas v Hello! Ltd* [2007] UKHL 21 (2 May 2007).

comfortable. Information about an individual's private life would not, in ordinary usage, be called 'confidential'. The more natural description today is that such information is private. The essence of the tort is better encapsulated now as misuse of private information.

In the case of individuals this tort, however labeled, affords respect for one aspect of an individual's privacy.

B. MIXED-LAW APPROACH

4. The duty to respect confidential information can either be contractual or delictual (based on tort).

ATLAS ORGANIC FERTILIZERS (PTY) LTD v PIKKEWYN GHWANO (PTY) LTD

1981 (2) SA 173 (T) [South Africa]

Insofar as the English action on breach of confidence is based on an implied contractual term relating to confidentiality of information acquired, it finds its counterpart in our law in the action on breach of contract.

A delictual action on 'breach of confidence' can only be a manifestation of the Aquilian action on unlawful competition and has to be determined according to the principles set out by me above.

C. CIVIL-LAW APPROACH

5. The relevant statutory provision applicable in Germany and Japan in this regard have been quoted earlier.²⁶¹ In Japan, for instance, the protection is dependent on three elements:²⁶²

- the utility of the information;
- the confidentiality of the information, i.e., the manner in which the plaintiff treated the information within its own organization (the information must, objectively speaking, have been treated as trade secrets); and
- the non-publicity of the information, i.e., whether the information was otherwise available.

261 See chapter 13 part B above.

262 "Aderans" Customer List Case, Osaka District Court, April 16, 1996 [Japan].

There does not appear to be any difference of consequence between this approach and the more detailed approach of the common law dealt with hereafter.

D. EMPLOYER-EMPLOYEE RELATIONSHIP

6. The breach of the duty to respect confidential information arises mostly within the context of employment agreements, especially as a result of their termination. A number of different legal concepts arise in this regard.

FACCENDA CHICKEN LTD v FOWLER

[1986] 1 All ER 617 (CA)

In these two appeals it will be necessary to consider the interaction of three separate legal concepts.

- The duty of an employee during the period of his employment to act with good faith towards his employer; this duty is sometimes called the duty of fidelity.
- The duty of an employee not to use or disclose after his employment has ceased any confidential information which he has obtained during his employment about his employer's affairs.
- The *prima facie* right of any person to use and to exploit for the purpose of earning his living all the skill, experience and knowledge which he has at his disposal, including skill, experience and knowledge which he has acquired in the course of previous periods of employment.

ALUM-PHOS (PTY) LTD v SPATZ

[1997] 1 All SA 616 (W) [South Africa]

It is an implied term of every contract of service that an employee will not use confidential information acquired during his period of service for his own benefit or to the detriment of his employer and such term binds the employee even after he has left the service of the employer. This term applies to all confidential information whether acquired honestly or dishonestly.

In order to qualify as confidential information, the information concerned must comply with three requirements.

- First, it must involve and be capable of application in trade or industry, i.e., it must be useful.

- Second, it must not be public knowledge and public property: i.e. objectively determined it must be known only to a restricted number of people or to a closed circle.
- Third, the information objectively determined must be of economic value to the person seeking to protect it. The nature of the information is irrelevant. If it complies with the requirements stated it will be confidential. Ordinary general information about a business does not become confidential because the proprietor chooses to call it confidential.

E. THE PROTECTION OF KNOW-HOW AND TRADE SECRETS

7. *The meaning of know-how:*

MYCALEX CORPORATION v PEMCO CORPORATION

64 F Supp 420 (1946) [USA]

[Know-how is] factual knowledge not capable of precise, separate description but which, when used in an accumulated form, after being acquired as the result of trial and error, gives to the one acquiring it an ability to produce something which he otherwise would not have known how to produce with the same accuracy or precision found necessary for commercial success.

8. *What is a trade secret?*

ANSELL RUBBER CO (PTY) LTD v ALLIED RUBBER INDUSTRIES (PTY) LTD

[1967] VR 37; [1972] RPC 811 [Australia]

There is very little in these English cases to enable one to identify a "trade secret". But some collation of the characteristics may be attempted, without trying to make it an exhaustive statement. Its subject-matter may not be a process in common use, or something which is public property and public knowledge, but if it is the result of work done by the maker upon materials which may be available for the use of anybody, so as to achieve a result which can only be produced by somebody who goes through the same process, it will be sufficient. All of its separate features may have been published, or capable of being ascertained by actual inspection by any member of the public, but if the whole result has not been achieved, and could not be achieved, except by someone going through the same kind of process as the owner, it will not fail to qualify by reason of the publication. It may derive from a maker in another country

without losing its character, if it is used, or entitled to be used, by the owner alone in the country in which the owner operates. There is no suggestion of the need for invention. Little can be gathered of the degree of secrecy required beyond what is implied in what is said. But it is a fair inference from what is said that the employer must have kept the matter to himself and from his competitors. The emphasis in the cases is on the confidence.

LANSING LINDE LTD v KERR

[1991] 1 All ER 418 (CA)

[W]hat are trade secrets and how do they differ (if at all) from confidential information? [Counsel] suggested that a trade secret is information which, if disclosed to a competitor, would be liable to cause real (or significant) harm to the owner of the secret. I would add first, that it must be information used in a trade or business, and secondly that the owner must limit the dissemination of it or at least not encourage or permit widespread publication. That is my preferred view of the meaning of trade secret in this context. It can thus include not only secret formulae for the manufacture of products but also, in an appropriate case, the names of customers and the goods which they buy."

F. USE OF STOCK OF KNOWLEDGE BY EX-EMPLOYEE

9. *The right to use general stock of knowledge.*

STEPHENSON JORDAN & HARRISON LTD v D MACDONALD & EVANS

(1952) 69 RPC 23:

A servant cannot help acquiring a great deal of knowledge of his master's method of business, and of the science which his master practices. The servant when he leaves cannot be restrained from using the knowledge so acquired, so long as he does not take away trade secrets or lists of customers.

The claim for breach of confidence seemed to be an attempt to acquire a monopoly of a branch of human knowledge which the law does not permit except so far as Parliament has authorized it.

ATLAS ORGANIC FERTILIZERS (PTY) LTD v PIKKEWYN GHWANO (PTY) LTD

1981 (2) SA 173 (T)

It is in the public interest that an employee who has in the course of his employment acquired skills and specialized knowledge of a particular trade or industry should be entitled to apply that elsewhere after termination of his employment. Our system of free enterprise requires for its successful functioning a competitive market where personal skills and expertise can be freely bartered.

It is clear that freedom of trade remains one of the ideals which should be given due consideration when public policy is determined.

- 10.** *An employee is entitled to use and put at the disposal of new employers all his acquired skill and knowledge:*

OCULAR SCIENCES LTD v ASPECT VISION CARE LTD

[1997] RPC 289

An employer, like anyone else, is entitled to restrain unauthorized disclosure or use of information which is confidential. On the other hand, for public policy reasons, an employee is entitled to use and put at the disposal of new employers all his acquired skill and knowledge. That is so, no matter where he acquired that skill and knowledge and whether it is secret or was so at the time he acquired it.

G. SPRINGBOARD²⁶³

- 11.** *The object of the doctrine:* The object of the springboard doctrine is to prevent a person who has breached a duty to keep matters confidential to capitalize on any head-start gained. The problems with this doctrine are manifold, especially when it concerns the issue of an injunction.²⁶⁴

TERRAPIN LTD v BUILDERS SUPPLY CO (HAYES) LTD

[1960] RPC 128 [UK]

As I understand it, the essence of this branch of the law, whatever the origin of it may be, is that a person who has obtained information in confidence is not allowed to use it as a springboard for activities detrimental to the person who made the confidential communication,

²⁶³ *Aim Maintenance Ltd v Brunt* [2004] WASC 49 [Western Australia].

²⁶⁴ *Ocular Sciences Ltd v Aspect Vision Care Ltd* [1997] RPC 289 [UK].

and springboard it remains even when all the features have been published or can be ascertained by actual inspection by any member of the public.

It is, in my view, inherent in the principle on which the *Saltman* case rests that the possessor of such information must be placed under a special disability in the field of competition in order to ensure that he does not get an unfair start; or, in other words, to preclude the tactics which the first defendants and the third defendants and the managing director of both of those companies employed in this case.

H. REMEDIES

12. The typical common-law remedies available for torts are available in these cases and they are discussed in later chapters. As far as springboard relief is concerned, an injunction in the following terms may be appropriate:²⁶⁵

The defendant is enjoined for a period of x months of marketing any vacuum cleaner under or by reference to the trade mark or name VORTEX, except that it shall not be a breach of this part of the Order to use the same mark or logo in a context where there is no likelihood of deception.

265 *Dyson Appliances Ltd v. Hoover Ltd* [2001] EWHC Patents.

EXHAUSTION OF IP RIGHTS

CHAPTER XVII

- A. INTRODUCTION (1-2)
- B. EXHAUSTION OF PATENT AND DESIGN RIGHTS (3-10)
- C. EXHAUSTION OF TRADEMARK RIGHTS (11-16)
- D. EXHAUSTION OF COPYRIGHT (17-18)

A. INTRODUCTION

1. *The meaning of exhaustion of IP rights:* Exhaustion of rights refers to the instance when the holder of an IP right places products subject to such a right in the distribution channels. The effect of this is that the IP right relating to that product is thereby exhausted, and the act of purchasing, using, repairing or selling the product cannot be an infringement of the right.
2. *Differences:* It is necessary to distinguish between the different IP rights for purposes of the doctrine of exhaustion because different rules and considerations apply depending on whether one is dealing with patent, designs, trademarks or copyright.

B. EXHAUSTION OF PATENT AND DESIGN RIGHTS

3. *Domestic exhaustion:* Domestic exhaustion is widely recognized as an established practice in local laws. They typically provide that patent or design rights are not infringed by the doing of anything in relation to products to which the patent or design has been applied or is incorporated where such products have been put on the market within the relevant jurisdiction by or with the consent of the registered proprietor.

ADAMS v BURKE

84 US 453 (1873) [USA]

When the patentee, or the person having his rights, sells a machine or instrument whose sole value is in its use, he receives the consideration for its use and he parts with the right to restrict that use. That is to say, the patentee or his assignee having in the act of sale received all the royalty or consideration which he claims for the use of his invention in that particular machine or instrument, it is open to the use of the purchaser without further restriction.

The principle applies to product and method claims.

QUANTA COMPUTER, INC. v. LG ELECTRONICS, INC

553 U.S. 617 (2008)

Nothing in this Court's approach to patent exhaustion supports LGE's argument that method patents cannot be exhausted. It is true that a patented method may not be sold in the same way as an article or device, but methods nonetheless may be "embodied" in a product, the sale of which exhausts patent rights.

Our precedents do not differentiate transactions involving embodiments of patented methods or processes from those involving patented apparatuses or materials. To the contrary, this Court has repeatedly held that method patents were exhausted by the sale of an item that embodied the method.

These cases rest on solid footing. Eliminating exhaustion for method patents would seriously undermine the exhaustion doctrine. Patentees seeking to avoid patent exhaustion could simply draft their patent claims to describe a method rather than an apparatus.

4. *Domestic exhaustion: civil and common law compared:* Speaking generally, the common law tends to give greater recognition to the freedom of contract than does the civil-law. Because the question of exhaustion is closely related to that of tacit or implied contract terms, there is a discernible difference between the two systems. Within the common law it is usually permitted to limit the rights of the vendor by agreement while the matter is not all that simple within the civil tradition. As Hirohito Nakada explains:²⁶⁶

“It seems that the United States courts and Japanese courts agree in that the patentee cannot control the patent exhaustion by its unilateral intention. However, the patentee can control the patent exhaustion by a valid contract in the United States, as opposed to the Japanese courts which do not allow the patentee to control the patent exhaustion by contract, and [they] also [established] objective standards to determine whether a patent is exhausted.”

STUKENBORG v UNITED STATES

372 F2d 498 [USA]

The doctrine of implied license often results in much the same conclusion as exhaustion, i.e., buying an article includes the implied right to use and resell the article. However, “while patent exhaustion stems from inherent limits on the grant of the patent right, implied license is a doctrine of quasi-contract, and depends on the beliefs and expectations of the parties to the sales transaction.”

BRAUN MEDICAL INC v ABBOTT LABS INC

124 F3d 1419 [USA]

An unconditional sale of a patented device exhausts the patentee’s right to control the purchaser’s use of the device the patentee has

bargained for, and received, an amount equal to the full value of the goods. This exhaustion doctrine, however, does not apply to an expressly conditional sale or license. In such a transaction, it is more reasonable to infer that the parties negotiated a price that reflects only the value of the 'use' rights conferred by the patentee. As a result, express conditions accompanying the sale or license of a patented product are generally upheld. Such express conditions, however, are contractual in nature and are subject to antitrust, patent, contract, and any other applicable law, as well as equitable considerations such as patent misuse. Accordingly, conditions that violate some law or equitable consideration are unenforceable. On the other hand, violation of valid conditions entitles the patentee to a remedy for either patent infringement or breach of contract.

In short, the circumstances of the sale indicate: (1) purchasers, including end users, are on notice of the single-use condition; (2) purchasers have an opportunity to reject the condition; and (3) the [product] is offered at a special price that reflects an exchange for a single-use condition. Based on these circumstances, the Court concludes that [the patentee] has not exhausted its rights.

5. *Third parties*: Third parties are not bound by conditional sales unless they had knowledge of the restriction.

ROUSSEL UCLAF SA v HOCKLEY INTERNATIONAL LTD

[1996] RPC 441 [UK]

It is the law that where the patentee supplies his product and at the time of the supply informs the person supplied (normally via the contract) that there are limitations as to what may be done with the product supplied then, provided those terms are brought home first to the person originally supplied and, second, to subsequent dealers in the product, no licence to carry out or do any act outside the terms of the licence runs with the goods.

If no limited license is imposed on them at the time of the first supply no amount of notice thereafter either to the original supplier or persons who derive title from him can turn the general licence into a limited licence.

Limited licenses require that notice be brought to the attention of every person down the chain. That is normally done by putting notice of the licence on the goods, but it can of course be done in

other ways. Once the goods are sold without a limited licence then the purchaser buys them free of any patent restriction.

6. *Sale of an essential part.* The sale or license of an essential (non-patented) element of a patented device may exhaust the patentee's right to exclude others from making, selling or using that device.

ANTON BAUER INC v PAG LTD

329 F3d 1343 [USA]

The sale of the unpatented female plate by [the patentee] is a complete transfer of the ownership of the plate. In effect, the sale extinguishes [the patentee's] right to control the use of the plate, because the plate can only be used in the patented combination and the combination must be completed by the purchaser.

QUANTA COMPUTER, INC. v. LG ELECTRONICS, INC

553 U.S. 617 (2008)

This Court most recently discussed patent exhaustion in *Univis*, 316 U. S. 241. The Court noted that:

“where one has sold an uncompleted article which, because it embodies essential features of his patented invention, is within the protection of his patent, and has destined the article to be finished by the purchaser in conformity to the patent, he has sold his invention so far as it is or may be embodied in that particular article.”

In sum, the Court concluded that the traditional bar on patent restrictions following the sale of an item applies when the item sufficiently embodies the patent—even if it does not completely practice the patent—such that its only and intended use is to be finished under the terms of the patent.

7. *Different claims or patents.* The sale of a particular product under a patent does not give rise to a license in relation to other claimed inventions under the same patent. The same applies across patents.

STUKENBORG v UNITED STATES

372 F2d 498 [USA]

Each claim of a patent gives to the patentee an exclusive right. The mere fact that a person has an implied license to use a device that

is covered by one set of claims does not give the person an implied license to use the device in combination with other devices in which the combination is covered by another set of claims.

QUANTA COMPUTER, INC. v. LG ELECTRONICS, INC

553 U.S. 617 (2008)

With regard to LGE's argument that exhaustion does not apply across patents, we agree on the general principle: The sale of a device that practices patent A does not, by virtue of practicing patent A, exhaust patent B. But if the device practices patent A *while substantially embodying* patent B, its relationship to patent A does not prevent exhaustion of patent B.

8. *The repair/reconstruction dichotomy*: The exhaustion principle implies that the purchaser may repair the product but that does not mean that the purchaser may reconstruct it.

JAZZ PHOTO CORP v US INT'L TRADE COMM INC

264 F3d 1094 [USA]

Underlying the repair/reconstruction dichotomy is the principle of exhaustion of the patent right. The unrestricted sale of a patented article, by or with the authority of the patentee, "exhausts" the patentee's right to control further sale and use of that article by enforcing the patent under which it was first sold. Thus when a patented device has been lawfully sold in the United States, subsequent purchasers inherit the same immunity under the doctrine of patent exhaustion. However, the prohibition that the product may not be the vehicle for a 'second creation of the patented entity' continues to apply, for such re-creation exceeds the rights that accompanied the initial sale.

ARO MFG CO INC v CONVERTIBLE TOP REPLACEMENT CO

365 US 336 (1961) [USA]

The decisions of this Court require the conclusion that reconstruction of a patented entity, comprised of unpatented elements, is limited to such a true reconstruction of the entity as to "in fact make a new article", after the entity, viewed as a whole, has become spent. In order to call the monopoly, conferred by the patent grant, into play for a second time, it must, indeed, be a second creation of the patented entity. Mere replacement of individual unpatented parts, one at a time, whether of the same part repeatedly or different

parts successively, is no more than the lawful right of the owner to repair his property. Repair is “the disassembly and cleaning of patented articles accompanied by replacement of unpatented parts that had become worn or spent, in order to preserve the utility for which the article was originally intended.” Reconstruction requires extensive reworking of the article such that there is a re-creation of the patented entity.

UNITED WIRE LTD v SCREEN REPAIR SERVICES (SCOTLAND) LTD

[1999] EWCA Civ 1986

In *British Leyland Motor Corporation v Armstrong Patent Co Ltd* [1986] AC 577, it was argued that a purchaser of a car had an implied licence to get it repaired so that he could fit spare parts not made by the copyright owner, which would, without a licence from the copyright owner of drawings depicting the parts, be made in infringement. The Court of Appeal rejected the idea that a manufacturer of spare parts had an implied licence to make them by reproducing British Leyland’s copyright works even though they were to be fitted on a British Leyland vehicle. Although the manufacturers’ appeal was allowed, the House of Lords agreed that the implied licence submission should be rejected. Lord Templeman reviewed the patent cases on repair and said this:

“There are substantial differences between patent law and copyright law in relation to repairs. First, a patent for an invention is only infringed, for present purposes, where the invention is a product, by a person who ‘makes’ or ‘uses’ the product without the consent of the proprietor of the patent. Where therefore a patented product is sold for use with the consent of the proprietor, repair of the patented product will not constitute an infringement; repair amounting to reconstruction will constitute the manufacture of a new and infringing product.

There is, in my view, no inconsistency between, on the one hand, allowing patent rights to be exercised to prevent the reproduction of an article covered by the patent and, on the other hand, not allowing copyright to be exercised in derogation of grant to prevent the reproduction of an article which is not covered by the copyright.”

The judgment of the Privy Council in *Canon Kabushiki Kaisha v Green Cartridge Co (Hong Kong) Ltd* [1997] AC 728 was given by Lord Hoffmann. In that case the sole issue before the Privy Council

was whether the acts of repair amounted to infringement of copyright. Lord Hoffmann said:

“Their Lordships would observe that the concept of a licence, namely something which ‘makes an action lawful, which without it had been unlawful’ is not really applicable to the repair of a patented article. Because repair is by definition something which does not amount to the manufacture of the patented article, it is not an infringement of the monopoly conferred by the patent. It cannot therefore be an unlawful act and needs no special licence to make it lawful, unless as part of a general implied licence to use the patented product at all, which is sometimes used to explain why mere user does not infringe the patentee’s monopoly. But this is perhaps better regarded as a consequence of the exhaustion of the patentee’s rights in respect of the particular article when it is sold.’

9. *The Japanese approach to domestic exhaustion:* The *Canon* case is one in which patent infringement was found and injunctive relief granted against recycled products made by refilling with ink the patented ink tanks for inkjet printers after the initial ink had been used up. Canon was the holder of a patent entitled “liquid container, manufacturing method of the container, package of the container, ink jet head cartridge consisting of the container integrated with a recording head, and liquid jet recorder”. Canon manufactured and sold the ink tanks described in claim 1 (invention of liquid container) using the process described in claim 10 (invention of manufacturing process of the liquid container). Canon brought the action based on claims 1 and 10.

Recycle Assist imported and sold ink tanks. Company Z manufactured products for Recycle Assist by refilling with ink used products of Canon, which were sold in Japan or overseas by Canon or its licensee. It was common cause that products of Recycle Assist met every constituent feature of claim 1 and fell within its technical scope, and the manufacturing process for products of Recycle Assist also met every constituent feature of claim 10 and fell within its technical scope. Recycle Assist argued that Canon should not be allowed to [enforce] the patent against products of Recycle Assist, claiming exhaustion of the Patent.

CANON INC v RECYCLE ASSIST CO LTD

[2006] JPIPHC 3 (31 January 2006)

Division Grand Panel

(a) *The general rule.*

[A] patent is not exhausted when one of the following conditions is met:

(i) the patented product is reused or recycled after it has finished its service along with the lapse of its ordinary life as a product (Type 1);

(ii) a third party has made the patented product is reused or recycled after it has finished its service along with the lapse of its ordinary life as a product (Type 2).

Whether the Type 1 condition is met should be determined based on the patented product by examining whether the patented product has finished its service as a product, whereas whether the Type 2 condition is met should be determined based on the invention by examining whether any modification or replacement has been made to the whole or part of the components that constitutes an essential portion of the patented invention.

(b) Since the patented product has not finished its service along with the lapse of its ordinary life as a product its reuse or recycle by refilling is permitted.

In this case, the Type 1 condition has not been met. Since no physical change or modification has been added to the components of the products of Canon other than use of the filled ink, the products of Canon can be reused as ink containers by refilling them with ink. Ink is an interchangeable part, and refilling ink can be deemed to be replacement of an interchangeable part. In the market of ink products for ink jet printers, not only genuine products including products of Canon but also recycled products and ink refills are available. Though quality of recycled products is often inferior to that of genuine products, they are widely accepted by users due to lower prices. Furthermore, recycling should be encouraged for the conservation of the environment unless it infringes upon another party's rights or interests. No laws or regulations prohibit the recycling of used ink tanks. Given these factors, the Court finds that the products of Canon have not spent their life as a product even if the initial ink has been used up. The Court concludes that the products of Canon do not meet the Type 1 condition.

(c) *But the Type 2 condition is met in this case, and claim 1 has not been exhausted because constituent features that are essential parts of the invention were used.*

The purpose of claim 1 is to solve the conventional problem of ink tanks, that is, ink leakage at the time the ink cartridge is unsealed, while ensuring the same effect for the conventional ink tanks, which is stable ink supply, by increasing the quantity of ink contained in the ink tank per unit volume. In order to fulfill the above mentioned purposes, claim 1 contains the following features; constituent feature H [and] constituent feature K. Those constituent features are essential parts of claim 1. The products of Canon lose constituent features H and K by the time a certain period of time has passed after the ink is used up and the ink tank is taken out of the printer. A third party produces products of Recycle Assist by cleaning the inside of the ink tanks of used products of Canon, which have lost their essential features by then, and injecting ink into them beyond the level of the interfaces of the negative pressure generating members. Through this manufacturing process, the products of Recycle Assist restore constituent features H and K of claim 1. Therefore, the Type 2 condition is met and exhaustion of claim should be denied. Canon should be allowed to exercise claim 1 against Products of Recycle Assist that are manufactured by refilling with ink used Products of Canon for domestic sale.

(d) *Exhaustion of the process claim (claim 10).*

The exercising of a process patent falls into two categories: use or assignment of the product manufactured using the claimed process, and the use of the process itself. The issue of exhaustion should be discussed separately for each respective category.

Although the exhaustion doctrine for a product patent does not apply as it is to the use of the patented process, the patent holder should not be allowed to exercise the patent where one of the following conditions is met:

(i) the product manufactured by the patented process is also patented as a product invention, with no difference in technical ideas between the process invention and the product invention, and the patent for the product invention has been exhausted, or

(ii) the patent holder or patent licensee has assigned articles that are to be used exclusively for the patented process or used for the

patented process (excluding those generally available in Japan) and that are indispensable for solving the problem through the patented invention, and the direct assignee or any subsequent assignee uses the patented process using the assigned articles, or uses or assigns products manufactured by the patented process using the assigned articles.

Since the products of Recycle Assist are manufactured through the process mentioned above, it can be said that the essential members are modified or replaced. Therefore, Canon is allowed to [enforce] claim 10 against products of Recycle Assist that are manufactured by refilling with ink used Products of Canon for domestic sale.

10. *International exhaustion:* The matter is not as simple with respect to international exhaustion and there is a lack of unanimity, particularly in connection with so-called parallel importation. The TRIPS Agreement (Art. 6) recognized this and merely states “that nothing in this Agreement shall be used to address the issue of the exhaustion of intellectual property rights.”²⁶⁷

The principle of territoriality has been dealt with earlier.²⁶⁸ What it means is that a patent has only effect within the jurisdiction where it is registered. This leads to the proposition that exhaustion of a patent in one country does not exhaust a similar patent in another country. The scope of the two may be different; and they may be held by unrelated parties.

KABUSHIKI KAISHA HATTORI SEIKO v REFAC TECHNOLOGY DEVELOPMENT

690 F. Supp. 1339 [USA]

In general, the first sale of a product by a patentee or licensee exhausts the patent monopoly, and deprives the holder of patent rights of any further control over resale of the product. This principle applies to an authorized first sale abroad by a patentee or licensee who also has the right to sell in the United States. Following such a sale, the holder of United States patent rights is barred from preventing resale in the United States or from collecting a royalty when the foreign customer resells the article here.

²⁶⁷ *Introduction to Intellectual Property Rights* Japanese Patent Office Asia-Pacific Industrial Property Center, III; John W. Osborne “Patent Exhaustion: a Standard Based on Patentable Distinctiveness” 20 *Santa Clara Computer & High Tech. LJ* 658.

²⁶⁸ See chapter XI part D above.

BBS CASE

Japan Supreme Court

1 July 1997

Once a Japanese patent owner has sold a patented product in Japan under his/her Japanese patent right, it should be considered that the patent right has achieved its purpose and has been exhausted. There is no need to allow double profits, and therefore the patent right cannot be enforced on the acts of using, selling or lending the already sold product in this situation.

On the other hand, a situation where a Japanese patent owner sells a patented product in another country is not necessarily analogous to the above situation. The patent owner does not necessarily own [the corresponding] patent in the other country on the same invention as in the Japanese patent. Even if the patent owner owns the corresponding patent, the Japanese patent right and the corresponding patent right are separate rights and independent of each other. Accordingly, the patent owner's enforcing his Japanese patent right against the products sold by himself/herself in the other country does not fall under double profits.

When a Japanese patent owner sells patented products to a purchaser in a foreign country without reservation, it is deemed that the patent owner implicitly assigns to the purchaser, or subsequent purchasers of the product, a right to control the patented products in Japan without restriction by the Japanese patent right.

On the other hand, it is possible for such patent owner to reserve the right to enforce its Japanese patent right in Japan when selling the patented products in the foreign country. If the patent owner agrees that Japan is excluded from the export destinations of the patented products, and such agreement is clearly indicated on the patented products, then even a subsequent purchaser who purchased through an intermediary will have notice of the agreement of exclusion on the patented products and will have been given an opportunity to decline the purchase because of the exclusion.

C. EXHAUSTION OF TRADEMARK RIGHTS

11. *The locus classicus*:²⁶⁹

CHAMPAGNE HEIDSIECK v BUXTON

[1930] 1 Ch 330

The facts: The plaintiffs, producers of champagne in France, prepared a special type of champagne for the English market, and another type (brut) for the French market. Both were sold under the same label which was registered as a trademark in England. The plaintiff wished to prevent the sale of the brut wine in England. It was nevertheless imported and sold by the defendant. The plaintiff claimed, unsuccessfully, an injunction to restrain the defendant from infringing its registered trademark.

It was, however, contended that the effect of s 3 of the Act of 1875 [which enacted that the registration of a trademark, prima facie, gave the registered proprietor the right to the exclusive use of such trademark] was of vesting in the owner of a trademark the right to object to any person selling or dealing with goods produced by the owner of the trademark with the trademark affixed, except on such terms and subject to such conditions as to resale, price, area of market, and so forth, as the owner of the trademark might choose to impose. It was, in effect, suggested that, whereas before 1875 a trademark, if established as a trademark, was a badge of the origin of the goods, the effect of s 3 was to make a registered trademark a badge of control, carrying with it the right in the owner of a registered trademark to full control over his goods, into whosoever hands they might come, except in so far as he might expressly or by implication have released this right of control.

I do not so read the section. It would be astonishing, if in an Act to establish a register of trademarks, such a remarkable extension of the rights of owners of trademarks were intended to be enacted by the use of such terms as appear in the section. The section appears to me to mean that the proprietor of a registered trademark is to have the right exclusively to use such trademark in the sense of preventing others from selling wares which are not his marked with the trademark.

²⁶⁹ This case has survived legislative changes and has since been applied in South Africa: *Protective Mining v Audiolens* 1987 (2) SA 961 (A); Australia: *R & A Bailey & Co Ltd v Boccaccio Pty Ltd* 77 ALR 177; Canada: *Kraft Canada Inc. v. Euro Excellence Inc* 2004 FC 652 (CanLII); and England: *Revlon Inc v Cripps & Lee Ltd* (1980) FSR 85 (CA). See, however, *Euro-Excellence Inc v Kraft Canada Inc* 2007 SCC 37.

The use of a mark by the defendant which is relied on as an infringement must be a use upon goods which are not the genuine goods, i.e. those upon which the plaintiffs' mark is properly used, for any one may use the plaintiffs' mark on the plaintiffs' goods, since that cannot cause the deception which is the test of infringement.

12. *A statutory example of the principle:* The principle, which in a sense is axiomatic, is nevertheless contained in some laws. The provision in Singapore is that:

a registered trademark is not infringed by the use of the trademark in relation to goods which have been put on the market, whether in Singapore or outside Singapore, under that trademark by the proprietor of the registered trademark or with his express or implied consent (conditional or otherwise).

This does not apply where:

- the condition of the goods has been changed or impaired after they have been put on the market; or
- the use of the registered trademark in relation to those goods has caused dilution in an unfair manner of the distinctive character of the registered trademark.

13. *The doctrine applies to the importation of grey goods (parallel importation):* Excluded from the definition of counterfeit goods are so-called parallel imports or grey market goods, which are trademarked goods, legitimately manufactured and sold in another country, and then imported into the local jurisdiction without the trademark owner's consent. The trademark on grey market goods is not counterfeit because it was placed there by or with the consent of the trademark owner, provided the goods were not subsequently modified or remarked.²⁷⁰ The principles all assume that the same party holds the relevant IP rights in both jurisdictions. If (for instance) they have been assigned to a third party in one jurisdiction, the defense may not hold. Quite often the degree of protection or lack of protection depends on local legislation.

JUDGMENT OF THE SUPREME COURT, THE FIRST PETTY BENCH

Case number: 2002 (Ju) No.1100 [Japan]

Minshu Vol.57, No.2, at 125

When a person other than an owner of a trademark right, with respect to the identical goods of the designated goods of a

270 See also *Glaxo Group Ltd v Dowelhurst Ltd* [2004] EWCA 290 Civ.

trademark in Japan, imports goods to which the identical trademark of the registered trademark is applied, upon satisfaction of following conditions, his act does not constitute infringement of the trademark right and it is not regarded as substantially illegal, because it is regarded as parallel importation of genuine goods:

- the said trademark is applied to the goods by an owner of a trademark right in a foreign country or by a person who is granted a license of the trademark,
- the said owner of the trademark right in a foreign country is the same person as the owner of the trademark right in Japan or they can be regarded as legally or economically identical, through which the trademark identifies the same origin as the registered trademark in Japan, and
- because the owner of the trademark in Japan is in a position to conduct quality control of the said goods directly or indirectly, with respect to the quality that is guaranteed by the said registered trademark, it can be regarded that there is no substantial difference between the said goods and the goods on which the registered trademark is applied by the owner of the trademark right in Japan.

14. *The TRIPS Agreement does not address the issue of parallel imports:* The TRIPS Agreement simply says that none of its provisions, except those dealing with non-discrimination (national treatment and most-favored-nation treatment), can be used to address the issue of exhaustion of intellectual property rights in a WTO dispute. In other words, even if a country allows parallel imports in a way that another country might think violates the TRIPS Agreement this cannot be raised as a dispute in the WTO unless fundamental principles of non-discrimination are involved.

15. *The effect of alterations:* Can the defendant alter the trademarked goods and still sell them under the owner's trademark? This judgment held in the negative. This would accord with the position in Singapore quoted above.

TELEVISION RADIO CENTRE (PTY) LTD v SONY CORPORATION

1987 (2) SA 994 (A) [South Africa]

The facts: Sony manufactured video cassette recorders and is the proprietor of the registered trademark "Sony" in respect of video cassette recorders. It made different types of recorders for different countries because recorders have to be compatible with the local television signal system. Thus, video cassette recorders which were not designed specifically for the South African system had to be adapted. The defendant imported Sony video cassette

recorders designed for use in the UK. Before selling the machines, the defendant had them adapted for use in South Africa. Sony alleged trademark infringement, a claim that was upheld.

No infringement of a trademark is committed by a trader who sells genuine goods properly marked with the trademark by or with the consent of the trademark owner. This is consonant with the origin of trademark infringement as a species of passing off. What the trademark proprietor is entitled to prevent is that the goods of another person are represented as his.

If another person alters the goods, they are, to the extent to which they have been altered, no longer the goods to which the trademark was affixed by the proprietor. It then, it seems to me, becomes a matter of degree whether there has been a change in the goods sufficiently appreciable to render them no longer the “genuine goods”, i.e. the goods which the trademark proprietor had marked. In determining this issue, one would have regard *inter alia* to the nature of the goods and the nature, purpose and extent of the alteration. This issue is essentially a practical one, and each case must be decided on its own facts in the light of ordinary business practice and the reasonable expectations of purchasers.

16. *The “fortress Europe” exception.* The European Economic Area has a different approach:²⁷¹

MASTERCIGARS DIRECT LTD v HUNTERS & FRANKAU LTD

[2007] EWCA Civ 176 [UK]

I suppose nearly all members of the public would think that you cannot infringe a trademark if you are just selling the genuine goods of the proprietor to which he has applied his trademark. Many (probably most) trademark lawyers think that *ought* to be the rule. After all, trademarks are the badge of the owner, a sign by which the consumer can know: ‘Here are the goods or services of a particular owner. I can rely on that sign.’ In the language of the Directive the function of a trademark is to ‘guarantee the trademark as an indication of origin’.

²⁷¹ See ECJ, 20 November 2001, *Zino Davidoff and Levi Strauss*, C-414/99 to C-416/99, ECR 2001, I-8691; and also the Dutch judgment: *Canon v Crown Rb Utrecht*, 11 July 2007. This is reflected in section 75 of the Irish Industrial Designs Act 2001, which provides that “the design right shall not be infringed by the doing of anything in relation to products to which the design has been applied or is incorporated where such products have been put on the market in a Member State of the EEA by or with the consent of the registered proprietor.”

So the public would be surprised to know (and perhaps somewhat resentful of the fact) that the law of the EEA is such that if genuine goods are available outside Europe much cheaper than they are here, traders cannot buy them and import them for sale here, unless the trademark owner has consented. Even though the trademark tells the truth, its use can be prevented without that consent.

The policy behind this rule has been called ‘fortress Europe.’ It has very substantial implications since nearly all goods (save perhaps some raw materials) bear trademarks. It means traders can use trademarks to partition Europe from the rest of the World Market. This can sometimes have beneficial effects (e.g. trademarks are perhaps the easiest of intellectual property rights to invoke to stop re-importation into Europe of pharmaceuticals sold cheaply in third world countries for local use). But generally the rule is self-evidently rather anti-competitive and protectionist. Our task is not to consider whether the rule is good or bad from an economic perspective. It is to apply it.

L’ORÉAL SA v eBAY INTERNATIONAL AG

ECJ, 12 July 2011, C-324/09

In that regard, the Court has repeatedly held that it is essential that the proprietor of a trade mark registered in a Member State can control the first placing of goods bearing that trade mark on the market.

The rule confers on the proprietor of a trade mark exclusive rights entitling him to prevent any third party from importing goods bearing that mark, offering the goods, or putting them on the market or stocking them for those purposes, whilst Article 7 of the directive and Article 13 of the regulation have laid down an exception to that rule, providing that the trade mark proprietor’s rights are exhausted where the goods have been put on the market in the EEA – or, in the case of a Community trade mark, in the EU – by the proprietor himself or with his consent

D. EXHAUSTION OF COPYRIGHT

17. *National exhaustion:* The principle of the exhaustion of rights also applies to copyright.²⁷²

The first sale doctrine limits the copyright owner's exclusive rights to authorize or distribute copies of a copyrighted work to the public. It provides that a sale of a lawfully made copy terminates the copyright holder's authority to interfere with or control subsequent sales or distributions of that particular copy. In short, through the first sale doctrine, the first purchaser and any subsequent purchaser of that specific copy of a copyrighted work receive the right to sell, display or dispose of their copy. If copyright owner A sells a copy of a work to B, B may sell that particular copy without violating the law. B does not, however, receive the right to reproduce and distribute additional copies made from that work. Thus, if B makes any unauthorized copies of that work, he or she violates the law."

INTERSTATE PARCEL EXPRESS CO PTY LTD v TIME-LIFE INTERNATIONAL (NEDERLANDS) BV

[1977] HCA 52 [Australia]

By the grant of a patent in traditional form, a patentee is granted exclusive power to "make, use, exercise and vend" the invention. The sale of a patented article, by the patentee, would be quite futile, from the point of view of the buyer, if the buyer was not entitled either to use or to resell the article which he had bought. It therefore seems necessary, in order to give business efficacy to such a sale, to imply a term that the patentee consents to the use of the patented article by the buyer and those claiming under him. The law accordingly does ordinarily imply the consent of the patentee 'to an undisturbed and unrestricted use' of the patented article. To make such an implication, for the purpose only of avoiding the restrictions upon the use of the article that would otherwise be imposed by the patent, seems to be perfectly consistent with the ordinary rules governing the implication of terms in contracts.

However no similar necessity exists to imply a term of this kind upon the sale of a book the subject of copyright. The owner of copyright has not the exclusive right to use or sell the work in which copyright subsists. The buyer of a book in which copyright subsists does not need the consent of the owner of the copyright

²⁷² *Prosecuting Intellectual Property Crimes.*

to read, or speaking generally to resell, the book. The necessity to imply a term in the contract which exists when a patented article is sold does not arise on the sale of a book the subject of copyright. It was not, and could not be, suggested that the sale of a copy of a book is a licence to do the acts comprised in the copyright and set out in s. 31 of the Act.

An owner of copyright who sells a book in which copyright subsists passes to the buyer all the rights of ownership. He does not however consent to any particular use of the book - generally speaking his consent is irrelevant. For the reasons given, the cases on patent law are distinguishable. In some circumstances when the owner of copyright sells a book his consent to a particular use may be implied. For example if the owner of copyright sold in America a commercial quantity of books for delivery to a buyer in Australia, whom he knew to be a bookseller, his consent to the importation of those books into Australia and their sale there might well be implied.

18. *International exhaustion*:²⁷³ Copyright may be in different hands in the country of export and the country of import. This may be as a result of an assignment of the rights. The South African case held that the copyright owner (who became owner by means of an assignment) in the importing country may prevent the importation.²⁷⁴ The later Canadian case of *Euro-Excellence* deals with the position of an exclusive licensee in the importing country and held that such a person may not prevent the importation of goods made under license of the copyright holder/licensor.

FRANK & HIRSCH (PTY) LTD v A ROOPANAND BROS (PTY) LTD

1993 (4) SA 279 (A) [South Africa]

The facts: This case represented a successful attempt to prevent parallel importation by means of the law of copyright. The appellant acted as the exclusive importer of TDK tapes in terms of a distributorship agreement entered into with the manufacturer of TDK tapes, TDK Electronics of Japan. To give effect to the exclusivity of the agreement, TDK Electronics assigned to appellant all its South African copyright in the literary and/or artistic works comprised in the get-up and trade dress of TDK tapes. It retained its copyright elsewhere. The respondent imported original TDK tapes, sourced through a third party. The relevant statutory provision relied upon provided

273 For the position in the EU: ECJ, 18 March 1980, *Coditel / Ciné Vog Films*, 62/79, ECR 1980, 881 and ECJ, 6 October 1982, *Coditel / Ciné-Vog Films*, 262/81, ECR 1982, 3381; *KK Sony Computer Entertainment & anr v Pacific Game Technology (Holding) Ltd* [2006] EWHC 2509 (Pat); *Independiente Ltd v Music Trading On-Line (HK) Ltd (t/a CD-WOW)* [2007] EWHC 533 (Ch)

274 Australia: *Interstate Parcel Express Co Pty Ltd v Time-Life International (Nederlands) BV* [1977] HCA 52.

that “copyright shall be infringed by any person who, without the licence of the owner of the copyright and at a time when copyright subsists in a work imports an article into the Republic [of South Africa] for a purpose other than for his private and domestic use.”

In terms of s 24(1) of the Act infringements of copyright are actionable at the suit of the ‘owner of the copyright’. Section 21 defines in whom ownership of copyright vests. And s 22 deals, inter alia, with assignment of copyright. The effect of a valid assignment is to vest in the assignee ownership of the copyright in the work or works covered by the assignment and entitles the assignee to sue for infringement of such copyright.

In the present case it is not in dispute that in terms of s 21 ownership of whatever copyright there is in the get-up of the tapes in issue originally vested in TDK; that this copyright, in so far as it obtained in South Africa, was validly assigned to F&H; and that such copyright still subsists. In order to complete its cause of action F&H had to establish also:

- that respondent imported into South Africa the tapes in issue for a purpose other than for his private or domestic use;
- that to respondent’s knowledge the making of the tapes in issue would have constituted such an infringement if the article had been made in South Africa; and
- that respondent had no licence from the owner of the copyright to do what he did.

It follows, as a logical corollary, that, if the person who made the article [i.e., TDK] could not lawfully (i.e., without infringing copyright) have made it in South Africa, a person who, with the requisite knowledge and without licence, either imports the article into South Africa or sells or distributes it here commits an infringement of copyright in terms of s 23(2).

In applying these statutory provisions, thus interpreted, to the facts of the present case, the cardinal questions which must be asked are: whether, if TDK had made the tapes in issue in South Africa, this would have constituted an infringement of F&H’s copyright

The assignment of the South African copyright in respect of the get-up of the tapes in issue vested in appellant exclusively all the rights comprehended by the South African copyright and divested TDK thereof. It follows that, hypothetically, the making in South Africa of

the get-up of the tapes in issue by TDK would have constituted an infringement of F&H's copyright.

EURO-EXCELLENCE INC v KRAFT CANADA INC

2007 SCC 37 [Canada]

The facts: This case has special facts and the different judgments make the judgment difficult to analyze. Accordingly, the headnote will be quoted. KCI is the exclusive Canadian distributor of Côte d'Or and Toblerone chocolate bars in Canada for its parent companies KFB and KFS. Notwithstanding the exclusivity agreements, Euro continued to import and distribute Côte d'Or and Toblerone bars which it had acquired [lawfully] in Europe. In order to allow KCI to mount the present case, KFB registered three Côte d'Or logos in Canada as copyrighted artistic works and granted KCI an exclusive licence in the works as used in association with confectionary products. KFS did the same with two Toblerone logos. KCI then called upon Euro to cease and desist distribution of any product to which the copyrighted works were affixed. When Euro refused, KCI brought an action against Euro alleging that it had engaged in secondary infringement under s. 27(2) of the *Copyright Act* by importing copies of KFS and KFB's copyrighted works into Canada for sale or distribution. KCI does not rely on its rights as a trademark holder.

For KCI to succeed, it must show that Euro imported works that would have infringed copyright if they had been made in Canada by the persons who made them. However, this hypothetical primary infringement cannot be established in this case. KFB and KFS made the impugned copies of the works in Europe. They would not have infringed copyright if they had produced the Côte d'Or and Toblerone logos in Canada because they are, respectively, the owners of the Canadian copyright in those logos. Because a copyright owner cannot be liable to its exclusive licensee for infringement, there is no hypothetical infringement, and thus no violation of s. 27(2)(e) of the *Copyright Act* in this case by Euro.

Section 27(2)(e), read in context with the definitional and liability provisions, leads to the necessary conclusion that an exclusive licensee may sue third parties for infringement, but not the owner-licensor of the copyright. The exclusive licensee's only remedy against the owner-licensor lies in contract.

PROVISIONAL REMEDIES

CHAPTER XVIII

- A. INTERNATIONAL STANDARDS (1-2)
- B. TEMPORARY INJUNCTIONS (3-4)
- C. THE OBJECT OF INTERIM INJUNCTIONS (5-6)
- D. THE DIFFERENT APPROACHES TO TEMPORARY INJUNCTIONS (7-11)
- E. SERIOUS QUESTIONS TO BE TRIED (12-17)
- F. IRREPARABLE HARM (18-20)
- G. BALANCE OF CONVENIENCE (21-23)
- H. SEIZURE ORDERS (24-26)
- I. ORDERS FOR THE PRESERVATION OF ASSETS (MAREVA INJUNCTIONS) (27-32)

A. INTERNATIONAL STANDARDS

1. *The TRIPS Agreement*: The TRIPS Agreement sets the minimum requirements for interim measures that Member countries are obliged to provide for all IP right holders. Article 50 provides in this regard as follows:

1. The judicial authorities shall have the authority to order prompt and effective provisional measures:
 - to prevent an infringement of any intellectual property right from occurring, and in particular to prevent the entry into the channels of commerce in their jurisdiction of goods, including imported goods immediately after customs clearance;
 - to preserve relevant evidence in regard to the alleged infringement.
2. The judicial authorities shall have the authority to adopt provisional measures *inaudita altera parte* where appropriate, in particular where any delay is likely to cause irreparable harm to the right holder, or where there is a demonstrable risk of evidence being destroyed.

This means that laws must provide for temporary injunctions (interim interdicts in the nomenclature of civil or mixed systems) on notice or, in cases of urgency, on an *ex parte* basis; and for search orders to preserve evidence (the so-called *Anton Piller* orders). Most jurisdictions comply in general, without special legislation, with these requirements.

2. *The European Directive No. 2004/48 of 29 April 2004 on the enforcement of intellectual property rights*²⁷⁵: This directive also deals with provisional remedies but in more detail. Article 9 provides:

1. Member States shall ensure that the judicial authorities may, at the request of the applicant:
 - (a) issue against the alleged infringer an interlocutory injunction intended to prevent any imminent infringement of an intellectual property right, or to forbid, on a provisional basis and subject, where appropriate, to a recurring penalty payment where provided for by national law, the continuation of the alleged infringements of that right, or to make such continuation subject to the lodging of guarantees intended to ensure the compensation of the right-holder; an interlocutory injunction may also be issued, under the same conditions, against an intermediary whose services are being

²⁷⁵ The European Commission announced, in a communication of May 24, 2011, that this Directive would be reviewed in 2012 (see: http://ec.europa.eu/internal_market/copyright/docs/ipr_strategy/COM_2011_287_en.pdf).

used by a third party to infringe an intellectual property right; injunctions against intermediaries whose services are used by a third party to infringe a copyright or a related right are covered by Directive 2001/29/EC;

(b) order the seizure or delivery up of the goods suspected of infringing an intellectual property right so as to prevent their entry into or movement within the channels of commerce.

2. In the case of an infringement committed on a commercial scale, the Member States shall ensure that, if the injured party demonstrates circumstances likely to endanger the recovery of damages, the judicial authorities may order the precautionary seizure of the movable and immovable property of the alleged infringer, including the blocking of his/her bank accounts and other assets. To that end, the competent authorities may order the communication of bank, financial or commercial documents, or appropriate access to the relevant information.

3. The judicial authorities shall, in respect of the measures referred to in paragraphs 1 and 2, have the authority to require the applicant to provide any reasonably available evidence in order to satisfy themselves with a sufficient degree of certainty that the applicant is the right-holder and that the applicant's right is being infringed, or that such infringement is imminent.

4. Member States shall ensure that the provisional measures referred to in paragraphs 1 and 2 may, in appropriate cases, be taken without the defendant having been heard, in particular where any delay would cause irreparable harm to the right-holder. In that event, the parties shall be so informed without delay after the execution of the measures at the latest.

A review, including a right to be heard, shall take place upon request of the defendant with a view to deciding, within a reasonable time after notification of the measures, whether those measures shall be modified, revoked or confirmed.

5. Member States shall ensure that the provisional measures referred to in paragraphs 1 and 2 are revoked or otherwise cease to have effect, upon request of the defendant, if the applicant does not institute, within a reasonable period, proceedings leading to a decision on the merits of the case before the competent judicial authority, the period to be determined by the judicial authority

ordering the measures where the law of a Member State so permits or, in the absence of such determination, within a period not exceeding 20 working days or 31 calendar days, whichever is the longer.

6. The competent judicial authorities may make the provisional measures referred to in paragraphs 1 and 2 subject to the lodging by the applicant of adequate security or an equivalent assurance intended to ensure compensation for any prejudice suffered by the defendant as provided for in paragraph 7.

7. Where the provisional measures are revoked or where they lapse due to any act or omission by the applicant, or where it is subsequently found that there has been no infringement or threat of infringement of an intellectual property right, the judicial authorities shall have the authority to order the applicant, upon request of the defendant, to provide the defendant appropriate compensation for any injury caused by those measures.

B. TEMPORARY INJUNCTIONS

3. *Advantages of the remedy:* One of the most important civil remedies for the breach of IP rights is a temporary injunction pending the full ventilation of the dispute at a trial. Apart from restoring the *status quo* and halting the allegedly infringing act, interim injunction proceedings usually provide parties with a preview of the opponent's case. As a result, cases are often settled or concluded without a trial. Interim interdicts are cost effective because they are decided urgently without a full hearing or oral evidence.

4. *Unjustifiable application of the remedy:* From the vantage point of the judiciary, there is often the temptation to grant interim relief provided the claimant provides some security without considering whether the claimant's claim has any validity. This is not justifiable. An interim injunction has far-reaching commercial consequences and it is seldom that the innocent respondent will be able to prove or recover its loss.

A court always has a wide discretion to refuse an interim interdict even if the requisites have been established. This means that the court is entitled to have regard to a number of disparate and incommensurable features in coming to a decision, and not that the court has a free and unfettered discretion. The discretion is a judicial one which must be exercised according to law and upon established facts.

C. THE OBJECT OF INTERIM INJUNCTIONS

5. *The purpose of interim relief is to regulate the interim and to preserve the status quo.*

ATTORNEY GENERAL v PUNCH LTD

[2002] UKHL 50

The purpose for which the court grants an interlocutory injunction can be stated quite simply. In *American Cyanamid Co v Ethicon Ltd* [1975] AC 396 Lord Diplock described it as a remedy which is both temporary and discretionary. Its purpose is to regulate, and where possible to preserve, the rights of the parties pending the final determination of the matter which is in issue by the court. That purpose should not be confused with the court's reasons for deciding that it would be appropriate to grant an interlocutory injunction. The court must of course have a good reason for granting an order of this kind. It must be satisfied in the first place that a sufficient ground has been stated to show that there is a real dispute between the parties. As Lord Diplock put it, the court must be satisfied that there is a serious question to be tried. It must then consider whether the balance of convenience lies in favor of granting or refusing an interlocutory injunction. But it is in no position to reach a final decision at the interlocutory stage on the matters which are in dispute between the parties. It is no part of the court's function at that stage to resolve conflicts of evidence or questions of law that require detailed argument. All it can do is to preserve the status quo in the meantime until these matters can be determined at the trial.

It is true, as Lord Phillips MR said, that in many cases the claimant's objective is achieved when an interlocutory injunction is granted and that the stage of a substantive hearing is never reached. This may be because the parties are content to settle their dispute at that stage or because the need for a final order has been overtaken by events.

But this does not alter the fact that the court's purpose, when it grants the order, is to preserve the rights of the parties pending a final determination of the issues between them by the court. Furthermore, as Lord Oliver said in *Attorney General v Times Newspapers Ltd* [1992] 1 AC 191, "purpose" in this context refers not to the litigant's purpose in obtaining the order or in fighting the action, but to the court's purpose. That is the purpose which the court was intending to fulfill in seeking to administer justice between the parties in the particular litigation of which it has become seized.

6. *To prevent the practical destruction of the right claimed:*

AUSTRALIAN BROADCASTING CORP v LENA GAME MEATS PTY LTD

[2001] HCA 63

Subject to any argument as to whether damages were an adequate remedy, there was a probability that such right would be rendered worthless if, before the final hearing, the appellant broadcast the material as and when it pleased. In order to preserve the subject matter of the dispute, and to prevent the practical destruction of the right claimed by the respondent before the action could be heard on a final basis, the [lower court] had power to grant an interlocutory injunction. Power of that nature has a long history, and is exercised according to principle, not unguided discretion. For present purposes, what is most significant is that the justice and convenience of granting an interlocutory injunction, in a case such as the present, is to be found in the purpose for which the power exists.

D. THE DIFFERENT APPROACHES TO TEMPORARY INJUNCTIONS

7. *English (common) law: The traditional versus the American Cyanamid approach:* The “serious question to be tried”-test replaced the former (strong) *prima facie* case-test. The requirement of a serious question to be tried is not the same as that of a *prima facie* right, although the court must be satisfied that the claim is not frivolous or vexatious

MANITOBA (A.G.) v METROPOLITAN STORES LTD

1987 CanLII 79 (SCC) [Canada]

The first test is a preliminary and tentative assessment of the merits of the case, but there is more than one way to describe this first test. The traditional way consists in asking whether the litigant who seeks the interlocutory injunction can make out a *prima facie* case. The injunction will be refused unless he can. The House of Lords has somewhat relaxed this first test in *American Cyanamid Co. v. Ethicon Ltd*, where it held that all that was necessary to meet this test was to satisfy the Court that there was a serious question to be tried as opposed to a frivolous or vexatious claim.

Countries that are inclined to follow English precedents tend to apply the *American Cyanamid*²⁷⁶ test for determining the entitlement to an interim injunction.

8. *Rejection of the prima facie test:* The judgment in *Cyanamid* rejected the *prima facie* case test for the following reason:

AMERICAN CYANAMID CO. v ETHICON LTD

[1975] AC 396 (HL)

The use of such expressions as ‘a probability’, ‘a prima facie case’ or ‘a strong prima facie case’ in the context of the exercise of a discretionary power to grant an interlocutory injunction leads to confusion as to the object sought to be achieved by this form of temporary relief. This court no doubt must be satisfied that the claim is not frivolous or vexatious; in other words, that there is a serious question to be tried.

It is no part of the court’s function at this stage of the litigation to try to resolve conflicts of evidence on affidavit as to facts on which the claims of either party may ultimately depend nor to decide difficult questions of law which call for detailed argument and mature considerations. These are matters to be dealt with at the trial.

9. *The American Cyanamid-requirements:*

MOTT v MOUNT EDON GOLD MINES

(1994) 12 ACLC 319 at 321:

- The applicant must satisfy the court there is a serious question to be tried;
- If there is a serious question to be tried, an injunction will not be granted if common-law damages would be an adequate remedy;
- If there is a serious question to be tried and damages would not be an adequate remedy, the court must then consider whether the balance of convenience lies in favor of granting or refusing the relief sought.

276 *American Cyanamid Co v Ethicon Ltd* [1975] AC 396 (HL). It has been adopted in Canada: *RJR-MacDonald Inc v Canada (AG)* [1994] 1 SCR 311 at 348; Australia: e.g. *Australian Coarse Grain Pool Pty Ltd v Barley Marketing Board of Queensland* (1983) 57 ALJR 425. In India, however, it does not apply to IP cases, and a patentee cannot, for instance rely on the presumption that the patent is valid and has to prove it, *prima facie*: *Gujarat Bottle v Coca Cola Co* 1995 (5) SCC 545; *Huemer v New Yesh Engineers* 1996 PTC 232. *Standipack v Oswal Trading* 1999 PTC (19) 479; “in an infringement act relating to a patent the plaintiff has to make out a *prima facie* case about the existence of the patent and its infringement by the defendant independently of grant of patent as such.”

- When considering the balance of convenience, the relative strength and weaknesses of the applicant's case may be taken into account, and
- The court should not attempt to decide factual conflicts arising from the affidavit material and nor should it determine difficult questions of law which require detailed argument.

10. *US law:* The law in the USA requires even more than a *prima facie* right.

POLYMER TECHNOLOGIES, INC v ANDREW P. BRIDWELL, H.A. SPEC. CO

103 F3d 970 [USA]

The grant or denial of a preliminary injunction pursuant to 35 USC §283 is within the discretion of the district court.

As the moving party, Polymer [the applicant] had to establish its right to a preliminary injunction in light of four factors:

- a reasonable likelihood of success on the merits;
- irreparable harm if the injunction were not granted;
- the balance of the hardships, and
- the impact of the injunction on the public interest.

If Polymer clearly established the first factor (by making a 'clear showing' of both validity and infringement), it was entitled to a rebuttable presumption in its favor regarding the second factor.

11. *The civil-law:* The civil-law approach is also different. The requisites for the right to claim an interim interdict are: (a) a *prima facie* right; (b) a well-grounded apprehension of irreparable harm if the interim relief is not granted and the ultimate relief is eventually granted; (c) that the balance of convenience favors the granting of an interim interdict; and (d) that the applicant has no other satisfactory remedy. In view of the discretionary nature of an interim interdict these requisites are not judged in isolation and they interact.

This requirement is spelt out in the quoted European Directive in these words:

The judicial authorities shall, in respect of the measures referred to in paragraphs 1 and 2, have the authority to require the applicant to provide any reasonably available evidence in order to satisfy themselves *with a sufficient degree of certainty* that the applicant is the right-holder and that the applicant's right is being infringed, or that such infringement is imminent.

BEECHAM GROUP LTD v B-M GROUP (PTY) LTD

1977 (1) SA 50 (T)

As to the question of the applicant's prospects of success in the action, the proper approach of the court in applications for a temporary interdict to restrain the infringement of a patent should, in my view, be that

"[the] applicant's right need not be shown by a balance of probabilities; it is sufficient if such right is prima facie established, though open to some doubt. The proper manner of approach is to take the facts as set out by the applicant together with any facts set out by the respondent which applicant cannot dispute and to consider whether, having regard to the inherent probabilities, the applicant should on those facts obtain final relief at a trial. The facts set up in contradiction by the respondent should then be considered, and if serious doubt is thrown upon the case of applicant he could not succeed."

In some cases it may be relatively easy to apply the above test. In others, it may be impossible for the court hearing an application for a temporary interdict to try to resolve, on affidavit, difficult questions of fact and law the decision of which may depend upon expert oral evidence on both sides properly tested in cross-examination. But that is not to say that the court should refrain from considering the relative strengths of the cases of each party on the question of validity and infringement, as part of its discretion to be exercised judicially upon a consideration of all the facts placed before it.

E. SERIOUS QUESTIONS TO BE TRIED

12. *The plaintiff's allegations must establish a ground for the grant of final relief.*²⁷⁷

AUSTRALIAN BROADCASTING CORP v LENA H GAME MEATS PTY LTD

[2001] HCA 63

When a plaintiff applies to a court for an interlocutory injunction, the first question counsel may be asked is: what is your equity? If a plaintiff, who has commenced an action seeking a permanent injunction, cannot demonstrate that, if the facts alleged are

277 Cf *Siskina v Distos Compania Naviera Sa* [1979] AC 210 [UK].

shown to be true, there will be a sufficiently plausible ground for the granting of final relief, then that may mean there is no basis for interlocutory relief.

The corollary of the proposition stated by Sir Frederick Jordan is that a plaintiff seeking an interlocutory injunction must be able to show sufficient color of right to the final relief, in aid of which interlocutory relief is sought. In *McCarty v The Council of the Municipality of North Sydney*, the Chief Judge in Equity described the proposition that a plaintiff seeking an interlocutory injunction must show at least a probability that he will succeed in establishing his title to the relief sought at the final hearing as “so well established that no authority is really needed in support of it”.

If there is no serious question to be tried because, upon examination, it appears that the facts alleged by the respondent cannot, as a matter of law, sustain such a right, then there is no subject matter to be preserved. There is then no justice in maintaining the status quo, because that depends upon restraining the appellant from doing something which, by hypothesis, the respondent has no right to prevent.

The extent to which it is necessary, or appropriate, to examine the legal merits of a plaintiff’s claim for final relief, in determining whether to grant an interlocutory injunction, will depend upon the circumstances of the case. There is no inflexible rule. It may depend upon the nature of the dispute. For example, if there is little room for argument about the legal basis of a plaintiff’s case, and the dispute is about the facts, a court may be persuaded easily, at an interlocutory stage, that there is sufficient evidence to show, *prima facie*, an entitlement to final relief. The court may then move on to discretionary considerations, including the balance of convenience.

- 13.** *Preliminary assessment of the merits:* The preliminary assessment has a low threshold.

RJR-MACDONALD INC. v. CANADA (ATTORNEY GENERAL)

1994 CanLII 117 (SCC) [Canada]

What then are the indicators of ‘a serious question to be tried’? There are no specific requirements which must be met in order to satisfy this test. The threshold is a low one. The judge on the application must make a preliminary assessment of the merits of the case. Once satisfied that the application is neither vexatious nor frivolous, the

motions judge should proceed to consider the second and third tests, even if of the opinion that the plaintiff is unlikely to succeed at trial. A prolonged examination of the merits is generally neither necessary nor desirable.

- 14.** *Contradictory evidence:* Contrary evidence by the respondent does not destroy the serious question to be tried.

AIM MAINTENANCE LTD v BRUNT

[2004] WASC 49 [Australia]

Thus in my view the proper approach to take here is to assess whether or not there is a serious issue to be tried on the basis of the issues pleaded and as to which there is evidence from the plaintiff. If there is material to support what is pleaded, then the fact the defendants would lead evidence to the contrary would not mean there is no serious issue to be tried, although that evidence is something to be taken into account when evaluating the relative strengths and weaknesses of the plaintiff's case, for the purpose of determining where the balance of convenience lies.

- 15.** *Purely legal issues:* The *American Cyanamid* approach applies where the issues are factual and not merely legal.

WEIR v HERMON

[2001] NICH 8 [Northern Ireland]

It is apparent from Lord Diplock's speech in *American Cyanamid v Ethicon* [1975] AC 396 that the principles that he was there stating applied where the interlocutory application to restrain a defendant from doing acts allegedly in violation of a plaintiff's legal rights is made on contested facts or where difficult questions of law arise requiring detailed arguments and mature consideration. It is clear from *Associated British Boards v TGWU* [1989] 2 All ER 822 that if the resolution of the issues in dispute would be resolved by the determination of a point of law that can be answered at the interlocutory stage the court should decide the point and dispose of the matter.

- 16.** *An order that is final in effect:* The *American Cyanamid* approach does also not apply where the interlocutory order will be final in effect.²⁷⁸

278 See also *New Zealand and Commonwealth Games v Telecom New Zealand* [1996] FSR 757 [New Zealand].

NWL LIMITED v WOODS

[1979] 3 All ER 614 [HL]

American Cyanamid, which enjoins the judge on an application for an interlocutory injunction to direct his attention to the balance of convenience as soon as he has satisfied himself that there is a serious question to be tried, was not dealing with a case in which the grant or refusal of an injunction at that stage would, in effect, dispose of the action finally in favor of whichever party was successful in the application, because there would be nothing left on which it was in the unsuccessful party's interest to proceed to trial.

Where, however, the grant or refusal of the interlocutory injunction will have the practical effect of putting an end to the action because the harm that will have been already caused to the losing party by its grant or its refusal is complete and of a kind for which money cannot constitute any worthwhile recompense, the degree of likelihood that the plaintiff would have succeeded in establishing his right to an injunction if the action had gone to trial is a factor to be brought into the balance by the judge in weighing the risks that injustice may result from his deciding the application one way rather than the other.

17. *The relative strength of the cases: American Cyanamid* does not prevent a consideration of the relative strengths of the cases of the parties.

SERIES 5 SOFTWARE LTD v. PHILIP CLARKE

[1996] FSR 273

In my view Lord Diplock did not intend by the last quoted passage to exclude consideration of the strength of the cases in most applications for interlocutory relief. It appears to me that what is intended is that the court should not attempt to resolve difficult issues of fact or law on an application for interlocutory relief. If, on the other hand, the court is able to come to a view as to the strength of the parties' cases on the credible evidence then it can do so. In fact, as any lawyer who has experience of interlocutory proceedings will know, it is frequently the case that it is easy to determine who is most likely to win the trial on the basis of the affidavit evidence and any exhibited contemporaneous documents. If it is apparent from that material that one party's case is much stronger than the other's then that is a matter the court should not ignore. To suggest otherwise would be to exclude from consideration an important factor and such exclusion would fly in the face of the flexibility advocated earlier in *American Cyanamid*.

DIALADEX COMMUNICATIONS INC. v CRAMMOND

(1987) 34 DLR (4 th) 392

Where the facts are not substantially in dispute, the plaintiffs must be able to establish a strong *prima facie* case and must show that they will suffer irreparable harm if the injunction is not granted. If there are facts in dispute, a lesser standard must be met. In that case, the plaintiffs must show that their case is not a frivolous one and there is a substantial question to be tried, and that, on the balance of convenience, an injunction should be granted.

F. IRREPARABLE HARM²⁷⁹**18. The object:****MANITOBA (AG) v METROPOLITAN STORES LTD**

1987 CanLII 79 (SCC) [Canada]

The second test consists in deciding whether the litigant who seeks the interlocutory injunction would, unless the injunction is granted, suffer irreparable harm, that is harm not susceptible or difficult to be compensated in damages. Some judges consider at the same time the situation of the other party to the litigation and ask themselves whether the granting of the interlocutory injunction would cause irreparable harm to this other party if the main action fails. Other judges take the view that this last aspect rather forms part of the balance of convenience.

19. Irreparable harm relates to the nature rather than to the magnitude of harm:**RJR-MACDONALD INC. v. CANADA (ATTORNEY GENERAL)**

1994 CanLII 117 (SCC) [Canada]

Irreparable refers to the nature of the harm suffered rather than its magnitude. It is harm which either cannot be quantified in monetary terms or which cannot be cured, usually because one party cannot collect damages from the other. Examples of the former include instances where one party will be put out of business by the court's decision; where one party will suffer permanent market loss or irrevocable damage to its business reputation; or where a permanent

279 See also *Symonds Cider & English Wine Co Ltd v Showerings (Ireland) Ltd* [1997] IEHC 1 [Ireland].

loss of natural resources will be the result when a challenged activity is not enjoined. The fact that one party may be impecunious does not automatically determine the application in favor of the other party who will not ultimately be able to collect damages, although it may be a relevant consideration.

20. *The evidence must not be speculative:*

PFIZER IRELAND PHARMACEUTICALS v LILLY ICOS LLC

2004 FC 223 [Canada]

As stated in *Imperial Chemical Industries PLC v Apotex, Inc* [1990] 1 FC 221 (CA):

“The jurisprudence in this Court establishes that the evidence as to irreparable harm must be clear and not speculative.”

I am not convinced that the plaintiff will suffer irreparable harm since the losses that Pfizer will incur by sharing the market with Lilly are reasonably calculable, and the other harm claimed by Pfizer is entirely of a speculative nature.

G. BALANCE OF CONVENIENCE

21. *A balancing act is required:*

AMERICAN CYANAMID v ETHICON

[1975] AC 396 [UK]

The plaintiff’s need for such protection must be weighed against the corresponding need for the defendant to be protected against injury resulting from his having been prevented from exercising his own legal rights for which he could not be adequately compensated under the plaintiff’s undertaking in damages if the uncertainty were resolved in the defendant’s favor at the trial. The court must weigh one need against another and determine where ‘the balance of convenience’ lies.

22. *The balance of inconvenience:*

MANITOBA (AG) v METROPOLITAN STORES LTD

1987 CanLII 79 (SCC) [Canada]

The third test, called the balance of convenience and which ought perhaps to be called more appropriately the balance of inconvenience, is a determination of which of the two parties will suffer the greater harm from the granting or refusal of an interlocutory injunction, pending a decision on the merits.

23. *The factors are many and case particular:*

RJR-MACDONALD INC v CANADA (ATTORNEY GENERAL)

1994 CanLII 117 (SCC) [Canada]

The factors which must be considered in assessing the ‘balance of inconvenience’ are numerous and will vary in each individual case. In *American Cyanamid*, Lord Diplock cautioned that:

“it would be unwise to attempt even to list all the various matters which may need to be taken into consideration in deciding where the balance lies, let alone to suggest the relative weight to be attached to them. These will vary from case to case.”

He added that “there may be many other special factors to be taken into consideration in the particular circumstances of individual cases”.

POLO/LAUREN CO LTD PARTNERSHIP v DINOON

2004 SCJ 44 [Mauritius]

As it is not easy for me to decide if the prejudice allegedly suffered can or cannot adequately be compensated by damages on contradictory affidavit evidence, I shall therefore turn to the question of balance of convenience.

Here, the respondents tried to play on emotion, putting forward the argument that in granting the interlocutory order, thousand of workers would lose their employment. They also relied on the fact that they had been using the Artistic Work which was associated with a trade mark registered in the name of the Aurdally Brothers and Co. Ltd. without any fraud and that to the knowledge of the authority for many years. However, it is beyond dispute that the registration of the trade mark in the name of Aurdally Brothers and

Co. Ltd. was not renewed by the authority but had been struck off the register of trade marks since the year 2000.

On the other hand, there is the very strong case of the applicant as to the ownership of the copyright of the Artistic Work. Moreover, consideration must also be given to the obligation of the State to comply with its international obligations coupled with the fact that there is an element of public order, for the legislator has made it an offence for anybody who infringes the copyright in a work. Consequently, in the public interest, the rule of law must be upheld against any private interest, more especially in the field of infringement of copyright which is legion and rampant. I also take judicial notice of the fact that the State is attempting to put order to show another image of the country other than that of being notoriously known as a haven for counterfeiters.

H. SEIZURE ORDERS

24. *History and scope of Anton Piller orders:* Seizure orders are required by both TRIPS and the European Directive. The latter provides as follows (Article 7):

1. Member States shall ensure that, even before the commencement of proceedings on the merits of the case, the competent judicial authorities may, on application by a party who has presented reasonably available evidence to support his/her claims that his/her intellectual property right has been infringed or is about to be infringed, order prompt and effective provisional measures to preserve relevant evidence in respect of the alleged infringement, subject to the protection of confidential information. Such measures may include the detailed description, with or without the taking of samples, or the physical seizure of the infringing goods, and, in appropriate cases, the materials and implements used in the production and/or distribution of these goods and the documents relating thereto. Those measures shall be taken, if necessary without the other party having been heard, in particular where any delay is likely to cause irreparable harm to the right-holder or where there is a demonstrable risk of evidence being destroyed.

Where measures to preserve evidence are adopted without the other party having been heard, the parties affected shall be given notice, without delay after the execution of the measures at the latest. A review, including a right to be heard, shall take place upon request of the parties affected with a view to deciding, within a reasonable

period after the notification of the measures, whether the measures shall be modified, revoked or confirmed.

2. Member States shall ensure that the measures to preserve evidence may be subject to the lodging by the applicant of adequate security or an equivalent assurance intended to ensure compensation for any prejudice suffered by the defendant as provided for in paragraph 4.

3. Member States shall ensure that the measures to preserve evidence are revoked or otherwise cease to have effect, upon request of the defendant, without prejudice to the damages which may be claimed, if the applicant does not institute, within a reasonable period, proceedings leading to a decision on the merits of the case before the competent judicial authority, the period to be determined by the judicial authority ordering the measures where the law of a Member State so permits or, in the absence of such determination, within a period not exceeding 20 working days or 31 calendar days, whichever is the longer.

4. Where the measures to preserve evidence are revoked, or where they lapse due to any act or omission by the applicant, or where it is subsequently found that there has been no infringement or threat of infringement of an intellectual property right, the judicial authorities shall have the authority to order the applicant, upon request of the defendant, to provide the defendant appropriate compensation for any injury caused by those measures.

25. *A full analysis of the remedy:* The European Court of Human Rights had the opportunity to deal with these types of orders and in order to assess their legitimacy it gave a useful exposition of their development under English law and their scope.

CHAPPELL v UNITED KINGDOM

[1990] 12 EHRR 1

(a) *[History]*

The High Court [in the UK] developed – in particular from 1974 onwards – the practice of granting in appropriate cases to the plaintiff or intending plaintiff in civil proceedings ‘Anton Piller orders’, so called after the name of a case in which their use was approved by the Court of Appeal (*Anton Piller KG v. Manufacturing Processes Ltd* [1976] 1 All ER 779). They are of a procedural and essentially

provisional nature only, being granted pending the trial of the action on the merits.

Whilst Anton Piller orders have been made in a wide variety of cases, the great majority are granted in proceedings involving allegations of infringement of patents, trade marks or copyright or of passing off. Of these, by far the most frequent have been cases involving pirate records, tapes and video cassettes, where the risks of suppression of evidence are especially strong.

(b) [*Purpose*]

One of the basic purposes of this interlocutory measure being to preserve for that trial evidence in the possession of the defendant or prospective defendant, its essence is surprise. For this reason, the court – by virtue, so it was held in the Anton Piller case, of a power deriving from its inherent jurisdiction – grants the order on an ex parte application, that is without the defendant's being given notice and without his being heard. For the same reason, the application is invariably heard in private and the defendant will become aware of the order's existence only when it is served on him with a view to immediate execution. Over the years, the principles governing the grant and the terms of these orders have been restated and refined in numerous judgments.

(c) [*Content of order*]

An Anton Piller order will normally contain restrictive or mandatory injunctions: prohibiting the defendant from dealing with materials that are the subject of the action; requiring the defendant to disclose the whereabouts of all such materials and details of suppliers and customers, and to deliver up the materials to the plaintiff; requiring the defendant to make an affidavit containing all the information to be disclosed by him under the order; requiring the defendant to permit the plaintiff to enter the premises for the purpose of searching for the items.

As regards this last injunction, the court will confine the items specified to documents and materials directly relating to the action. It will also restrict the time of entry and the number of persons who are to be permitted to enter (very rarely more than four or five). The latter will include the plaintiff's solicitor, who is an officer of the court.

(d) [*Requirements for order*]

Before making an Anton Piller order, the court must be satisfied that:

- the plaintiff has made out an extremely strong *prima facie* case that his claim will succeed on the merits;
- the actual or potential damage is very serious for him; and
- there is clear evidence that the defendant has in his possession incriminating documents or things, and that there is a real possibility that, if he is forewarned, he may destroy such material.

(e) [*Undertakings*]

If so satisfied, the court will nevertheless accede to the application only on terms which will be incorporated in its written order, in the form of undertakings given to the court. These are designed to protect the position of the absent defendant, counsel for the plaintiff being under a duty to ensure that the order contains all proper safeguards for this purpose. The court determines in its discretion what undertakings are to be given, there being no invariable rules or practice in this respect. Examples are the following, item (a) being found in all, and items (b), (c) (i) and (c) (ii) in most cases:

- an undertaking by the plaintiff to pay to the defendant any damages sustained by him as a result of the making of the order;
- an undertaking by the plaintiff that the order and other relevant documents, such as the affidavit evidence underlying it, the writ instituting the proceedings and the notice of the next hearing, will be served on the defendant by the plaintiff's solicitors;
- undertakings by those solicitors:
 - to offer to explain to the person served, fairly and in everyday language, the meaning and effect of the order, and to inform him that he has the right to obtain legal advice before complying with the order or parts thereof, provided such advice is obtained forthwith;
 - to retain in their custody any items taken by or delivered to them pursuant to the order;
 - to answer any question from the defendant as to whether an item is within the scope of the order;
 - to prepare, before their removal from the premises, a list of the items taken;
 - to use any information or document obtained under the order

- to ensure that the exercise of rights under the order remains at all times under the control of a solicitor.

(f) [*Execution*]

In addition to the fact that it is issued to a private party in civil proceedings, and not to the police in criminal proceedings, an Anton Piller order is to be distinguished from a search warrant in that it confers no right of forcible entry onto premises. Its terms require the defendant to permit the plaintiff to enter, but it remains open to the defendant to refuse and, if he so wishes, to apply by urgent motion for variation or discharge of the order. He is, however, under pressure to give permission, especially since refusal to comply will expose him to the risk of proceedings for contempt of court on the motion of the plaintiff, with a possible penalty of imprisonment. Moreover, even if the defendant later succeeds in having the order discharged, his disobedience whilst it was in force will – unless it was made in circumstances in which it was a nullity in law – still constitute a contempt, albeit one which will probably be treated as technical and will usually attract no penalty.

(g) [*Remedies for the defendant*]

An Anton Piller order will expressly reserve to the defendant liberty to apply by urgent motion for its variation or discharge on giving specified notice to the plaintiff (usually 24 hours but sometimes less). Being an essentially provisional measure, it will in any event limit the duration of the relief which it affords to a specified period, generally about one week. On the expiry of that period, there will in principle be a hearing *inter partes* at which the court will review the order and consider whether the relief should be continued. On that occasion, or at any time subsequently, the defendant may apply for the order to be varied or discharged. Whilst the court may set aside the order even after its execution, it will not do so unless discharge was applied for reasonably soon thereafter and will serve some practical purpose

An Anton Piller order can be set aside if there existed no, or no sufficient, grounds for its making, if the plaintiff failed to disclose material facts when applying for it or, it seems, if it was improperly or oppressively executed. If the order is set aside, the defendant will be relieved from complying with the injunctions contained therein and any materials seized thereunder will be returned to

him. Partial relief of a similar nature may also be granted by the court even if the application for discharge is unsuccessful.

In addition or as an alternative to applying for the order's discharge, the defendant may seek damages under the plaintiff's cross-undertaking on the ground that the order was improperly obtained or executed. Damages may be awarded even if the order is not set aside and even if the plaintiff's action succeeds on the merits. Whilst they may be determined earlier, claims for damages are usually stood over until the trial on the merits. Damages are primarily intended to compensate the defendant for loss occasioned by the order but they may be aggravated if it was executed in an excessive or improper manner.

If the defendant considers that the plaintiff or his solicitors are in breach of their undertakings contained in the Anton Piller order or that the latter have acted improperly in executing it, he can proceed against them for contempt of court.

(h) [*Form of order*]

The order contained, *inter alia*, the following.

- An injunction prohibiting the defendants from making, selling, hiring, distributing or parting with possession of any unlicensed copies of any films the copyright in which was owned by the plaintiffs, and from parting with possession of any documents relating to the supply of such copies to or by the defendants.
- An injunction requiring the defendants to permit not more than three persons authorized by the plaintiffs, together with a solicitor and one other solicitor or employee of the plaintiffs' solicitors, to enter forthwith specified premises on any weekday between 8 a.m. and 9 p.m. for the purpose of searching for and removing into the custody of the plaintiffs' solicitors any unlicensed copies of those films and any documents appearing to relate to the acquisition, supply or disposal of such copies.
- An injunction requiring the defendants to reveal to the plaintiffs' solicitors the whereabouts of, and to deliver to them, all the aforesaid copies and documents in the defendants' possession.
- Injunctions requiring the defendants to disclose to the plaintiffs' solicitors the names and addresses of the defendants' suppliers of and customers for unlicensed copies of the films; and to swear, within four days after the service of the order, an affidavit setting forth this information.

26. *Pre-requisites for the order:*

ANTON PILLER KG v MANUFACTURING PROCESSES LTD

[1976] Ch 55

There are three essential pre-conditions for the making of such an order, in my judgment. First, there must be an extremely strong prima facie case. Secondly, the damage, potential or actual, must be very serious for the applicant. Thirdly, there must be clear evidence that the defendants have in their possession incriminating documents or things, and that there is a real possibility that they may destroy such material before any application *inter partes* can be made.

SHOBA v OFFICER COMMANDING

1995 (4) SA 1 (A)

I would define what an applicant for such an order, obtained in camera and without notice to the respondent, must prima facie establish, as the following:

- that he, the applicant, has a cause of action against the respondent which he intends to pursue;
- that the respondent has in his possession specific (and specified) documents or things which constitute vital evidence in substantiation of applicant's cause of action (but in respect of which applicant cannot claim a real or personal right); and
- that there is a real and well-founded apprehension that this evidence may be hidden or destroyed or in some manner be spirited away by the time the case comes to trial or to the stage of discovery.

I have used the words "vital evidence" in the sense of being evidence of great importance to the applicant's case.

I. ORDERS FOR THE PRESERVATION OF ASSETS (MAREVA INJUNCTIONS)

27. The so-called Mareva injunction is a temporary injunction and the name derives from the judgment in *The Mareva*.²⁸⁰ Its object is to prevent the dissipation of assets pending the disposition of the claimant's claim for damages by providing the only just and convenient way of ensuring that

280 *Mareva Compania Naviera S.A. v International Bulkcarriers S.A.*, [1975] 2 Lloyd's LR 509 (CA).

the defendant would not deal with its assets so as to deprive the plaintiff of the fruits of any future judgment; and it ought to be distinguished from injunctions where the claimant has a proprietary or other interest in the particular asset, and also from an Anton Piller order.

DEN NORSKE BANK ASA v ANTONATOS

[1998] EWCA Civ 649

Sometimes Mareva orders are simply designed to protect assets generally in order to meet an ultimate judgment; sometimes they are designed to trace and protect specific assets to which the plaintiff claims a proprietary remedy; sometimes they get close to being an Anton Piller order designed to obtain evidence of fraud which might otherwise be destroyed. Sometimes the form of order does not distinguish clearly between its objectives.

28. *Comparative law*:²⁸¹ This judgment provides a comparative overview.

KARL CONSTRUCTION LTD v PALISADE PROPERTIES PLC

[2002] ScotCS 350

(a) [*General availability*]

I was referred to materials dealing with a substantial number of other legal systems. In all of these systems a remedy is available to entitle a pursuer to obtain protective security for the sum sued for in a depending action. In no instance, however, is such security available automatically on the raising of an action; in nearly every case, the pursuer is required to establish two matters: first, that he has a *prima facie* case against the defender, or at least a claim that is capable of precise evaluation; and, second, that there are special reasons to suppose that the defender may not be able to satisfy his claim.

(b) [*Continental Europe*]

The remedies available in continental Europe are summarised by Professor Maher in a valuable article, "Diligence on the Dependence: Principles for Reform" 1996 JR 188. He states:

"Of the systems [in continental Europe] looked at by the Commission, five features recur. These are: (1) a pursuer must establish cause shown for the remedy in terms of the merits

281 This judgment does not deal with IP issues, but the same principles apply.

of the action; (2) the pursuer must also establish the need for an interim remedy; (3) a pursuer must lodge security in respect of the defender's loss where the pursuer's claim fails; (4) damages automatically ensue either if the pursuer loses on the merits or where the provisional remedy is unnecessary; and, (5) applications for a remedy are made to a judge. Another feature common to most European systems is that: (6) application may be made *ex parte*, usually on cause shown for this step, but the resulting remedy is temporary only, and calls for the pursuer to validate it at a subsequent contested hearing."

(c) [*England and Wales and also Ireland*]

In England and Wales, the corresponding procedure is the *Mareva* injunction. This is a relatively recent procedure, dating from the decision of the Court of Appeal in *Mareva Compania Naviera S.A. v International Bulkcarriers S.A.*, [1975] 2 Lloyd's LR 509. The principles governing *Mareva* injunctions are summarized by Professor Maher as follows:²⁸²

- An application for a *Mareva* injunction may be made only to a judge of the High Court, not the County Court;
- the plaintiff must show that he has a good arguable case;
- the plaintiff must show that there is a real risk that the defendant may remove or conceal his assets or deal with them so as to defeat the plaintiff's claim;
- the plaintiff must make a full and frank disclosure of all material facts known to him (including those unfavorable to his case), and failure to do so will result in the injunction being discharged;
- the plaintiff must give an undertaking in damages in case either he fails on the merits of the action or the injunction turns out to be unjustified.

(d) [*US and Canada*]

Professor Maher's article also considers protective attachment in the United States and Canada. He summarizes the principles that have generally been applied in American and Canadian jurisdictions as follows:

- The remedies which are equivalent to diligence on the dependence in Scots law are classified as part of the general law on pre-judgment remedies, and should be coherent with the underlying principles of that branch of the law.

²⁸² See *Rasu Maritima S.A.* [1978] QB 644; *Third Chandris Shipping Corporation v Unimarine S.A.*, [1979] QB 645.

- As such, these remedies are extraordinary in nature.
- Accordingly, there must exist meaningful substantive grounds to justify the granting of these remedies.
- The substantive grounds relate both to the plaintiff's chances of success in the action, and a shown need for the remedy.
- In addition procedural due process requires that these substantive grounds are considered by a judge before a remedy can be granted.
- Procedural due process also raises a presumption that the defendant is given an advance notice of the application and hearing prior to any grant of the remedy.
- This presumption may be rebutted but only if the plaintiff can show good cause for so doing and subject to safeguards to protect the defendant's position.
- These safeguards include the provisional nature of a remedy granted on an *ex parte* application, with a resulting need for a validation hearing where the onus is with the plaintiff; undertakings by the plaintiff where the remedy proves unjustified, i.e. where the plaintiff does not succeed in the action or the plaintiff cannot establish that special circumstances exist to justify its need.'

29. *The object of the order:* The object of the order is not to provide security but to prevent dissipation of assets.

KNOX D'ARCY LTD v JAMIESON

[1996] 3 All SA 669 (A)

As far as its name is concerned, the petitioners referred to it as a Mareva type interdict after the term used in English law. The court *a quo* did not like this name since the use of the English term might suggest that English principles are automatically applicable. I agree with this criticism. The alternatives suggested by [the learned judge] were not, however, much more felicitous. Thus he referred to an interdict *in securitatem debiti* and an anti-dissipation interdict. The former expression may suggest that the purpose of the interdict is to provide security for the applicant's claim. This is not so. The interdict prevents the respondent from dealing freely with his assets but grants the applicant no preferential rights over those assets. And 'anti-dissipation' suffers from the defect that in most cases, and certainly in the present case, the interdict is not sought to prevent the respondent from dissipating his assets, but rather from preserving them so well that the applicant cannot get his hands on them. Having criticized the names used for the interdict I find myself unfortunately

unable to suggest a better one. I console myself with the thought that our law has recognized this type of interdict for many years without giving it any specific name.

The question which arises from this approach is whether an applicant need show a particular state of mind on the part of the respondent, i.e., that he is getting rid of the funds, or is likely to do so, with the intention of defeating the claims of creditors. Having regard to the purpose of this type of interdict the answer must be, I consider, yes, except possibly in exceptional cases. As I have said, the effect of the interdict is to prevent the respondent from freely dealing with his own property to which the applicant lays no claim. Justice may require this restriction in cases where the respondent is shown to be acting *mala fide* with the intent of preventing execution in respect of the applicant's claim. However, there would not normally be any justification to compel a respondent to regulate his *bona fide* expenditure so as to retain funds in his patrimony for the payment of claims (particularly disputed ones) against him. I am not, of course, at the moment dealing with special situations which might arise, for instance, by contract or under the law of insolvency.

The purpose of the interdict is not to be a substitute for the claim for damages but to reinforce it – to render it more effective. And the question whether the claim is a satisfactory remedy in the absence of an interdict would normally answer itself. Except where the respondent is a *Croesus*, a claim for damages buttressed by an interdict of this sort is always more satisfactory for the plaintiff/applicant than one standing on its own feet. The question of an alternative remedy accordingly does not arise in this sort of case. The interdict with which we are dealing is *sui generis*. It is either available or it is not. No other remedy can really take its place (except, possibly, in certain circumstances, attachments or arrests).

30. *Requirements for a world-wide order:*

BANK (GIBRALTAR) LTD v SPJELDNAES

[1998] EWCA Civ 1101 [UK]

It is trite law that an applicant for a worldwide Mareva must satisfy the court that (1) he has a good arguable case, (2) the respondent has an insufficiency of assets within the jurisdiction and assets exist outside the jurisdiction, and (3) there is a risk of dissipation of the assets unless an injunction is granted. It is also

well established that [an appeal] court should be slow to interfere with the exercise of discretion by the judge in granting or refusing a Mareva injunction and should only do so if satisfied that there has been an error of principle.

31. *Basis of jurisdiction:* The jurisdiction is the same as that for the grant of temporary injunctions but it has been extended.²⁸³

CREDIT SUISSE FIDES TRUST SA v SERGIO CUOGHI

[1997] EWCA Civ 1831

This last step was taken in *Babanaft Co SA v Basatne* [1990] Ch 13, in which the court was concerned not to make an unwarranted assumption of extra-territorial jurisdiction. It recognized that it would be wrong to make an order which, though purporting merely to restrain the actions of a defendant already subject to the jurisdiction of the court, might be understood to impose obligations upon persons resident abroad and not subject to its jurisdiction. This danger was avoided by including provisions in the order which made it clear that it was not to affect parties not subject to the jurisdiction of the court in respect of acts outside the jurisdiction save to the extent that the order might be enforced by the local courts. The jurisdiction to make such orders is now firmly established. It is exercised with caution, and a sufficient case to justify its exercise must always be made out; but such orders are nowadays routinely made in cases of international fraud and the conditions necessary in order to preserve international comity and prevent conflicts of jurisdiction have become standardized. Before 1982 the court could not grant interlocutory relief when the substantive proceedings were taking place abroad. The position has now been reached, therefore, that the High Court has power to grant interim relief in aid of substantive proceedings elsewhere of whatever kind and wherever taking place.

32. *Disclosure may be ordered:* This is in accordance with the provisions of TRIPS (Article 47), which provide:

Members may provide that the judicial authorities shall have the authority, unless this would be out of proportion to the seriousness of the infringement, to order the infringer to inform the right holder of the identity of third persons involved in the production and distribution of the infringing goods or services and of their channels of distribution.

²⁸³ *Walsh v Deloitte & Touche Inc (Bahamas)* [2001] UKPC 58 [Bahamas].

INJUNCTIONS (INTERDICTS)

CHAPTER XIX

- A. INTERNATIONAL STANDARDS (1-3)
- B. THE SCOPE OF AN INJUNCTION (4-5)
- C. THE NATURE OF AN INJUNCTION (6-10)
- D. FORM OF INJUNCTION (11-12)

A. INTERNATIONAL STANDARDS

1. *TRIPS*: Article 44.1 of TRIPS requires the availability of injunctions (interdicts)²⁸⁴ under local law in these terms:

The judicial authorities shall have the authority to order a party to desist from an infringement, *inter alia* to prevent the entry into the channels of commerce in their jurisdiction of imported goods that involve the infringement of an intellectual property right, immediately after customs clearance of such goods.

Members are not obliged to accord such authority in respect of protected subject matter acquired or ordered by a person prior to knowing or having reasonable grounds to know that dealing in such subject matter would entail the infringement of an intellectual property right.

2. *The European Directive No. 2004/48 of 29 April 2004 on the enforcement of intellectual property rights*: Article 11 provides as follows:

Member States shall ensure that, where a judicial decision is taken finding an infringement of an intellectual property right, the judicial authorities may issue against the infringer an injunction aimed at prohibiting the continuation of the infringement. Where provided for by national law, non-compliance with an injunction shall, where appropriate, be subject to a recurring penalty payment, with a view to ensuring compliance. Member States shall also ensure that right-holders are in a position to apply for an injunction against intermediaries whose services are used by a third party to infringe an intellectual property right, without prejudice to Article 8(3) of Directive 2001/29/EC.

L'ORÉAL SA v eBAY INTERNATIONAL AG

ECJ, 12 July 2011, C-324/09

In view of the foregoing, the answer to the tenth question is that the third sentence of Article 11 of Directive 2004/48 must be interpreted as requiring the Member States to ensure that the national courts with jurisdiction in relation to the protection of intellectual property rights are able to order the operator of an online marketplace to take measures which contribute, not only to bringing to an end infringements of those rights by users of that marketplace, but also to preventing further infringements of that kind.

²⁸⁴ For the sake of convenience the English law term of injunction will be used in this text while recognizing that the civil systems prefer the term interdict. There is not any substantive difference between the two.

Those injunctions must be effective, proportionate, dissuasive and must not create barriers to legitimate trade.

3. Destruction of goods. A related remedy is one for the destruction of infringing goods in order to prevent them from entering channels of commerce. This is no different from the age-old remedy of delivery-up for destruction. Courts may make such orders by virtue of their inherent jurisdiction to regulate their own affairs and to ensure that their injunctions are effective. TRIPS also has such a requirement (Art. 46) as has the mentioned European Directive. These are dealt with in Part C.

B. THE SCOPE OF AN INJUNCTION

4. The nature of the wrongful act: The power of the court to grant an injunction is limited by the nature of the act which it is sought to restrain.

CARDILE v LED BUILDERS PTY LIMITED

[1999] HCA 18 [Australia]

However, in England, it is now settled by several decisions of the House of Lords that the power stated in Judicature legislation – that the court may grant an injunction in all cases in which it appears to the court to be just and convenient to do so – does not confer an unlimited power to grant injunctive relief. Regard must still be had to the existence of a legal or equitable right which the injunction protects against invasion or threatened invasion, or other unconscientious conduct or exercise of legal or equitable rights. The situation thus confirmed by these authorities reflects the point made by Ashburner that ‘the power of the court to grant an injunction is limited by the nature of the act which it is sought to restrain’.

COFLEXIP STENA OFFSHORE LIMITED, COFLEXIP S.A.

[1999] EWHC Patents 258

In a patent action the plaintiff normally alleges that the defendant has committed one or two specific types of infringement. They have to be identified in the plaintiff’s pleadings. In virtually all cases, the infringement will occupy just a small part of the monopoly secured by the patent and its claims. Further, in almost all cases, it is only the activities identified in the particulars of infringement which the defendant threatens to continue. He has not threatened to commit any other acts. The effect of a broad injunction would be to restrain the defendant from doing things he has not threatened to do, may never have thought of doing and may be incapable of doing.

The court has not considered, let alone determined, whether and what other activities infringe. This point can arise in any intellectual property right litigation but it is particularly significant in patent litigation. It sometimes happens either shortly before or during the course of a trial that the patentee finds another, different, activity of the defendant which he wants to add to the particulars of infringement. Because the issue of infringement may raise new questions of fact and involve expert evidence, it is common for the courts to decline leave to amend the pleadings if that course is likely to prejudice the trial date. The plaintiff will have to start separate proceedings if, notwithstanding his success in the first action, the defendant insists on maintaining his right to continue with the second activity. There is nothing abusive in the defendant deciding to take that position. Even assuming it is not open to him to challenge again the validity of the patent (an issue which does not arise here for consideration), it is legitimate for him to argue non-infringement. In relation to that, no question of issue estoppel or *res judicata* arises.

5. *The rules relating to injunctions in intellectual property cases are no different from those applicable in other cases:*

EBAY INC v MERCEXCHANGE LLC

550 US (2007) [USA]

Thomas J

According to well-established principles of equity, a plaintiff seeking a permanent injunction must satisfy a four-factor test before a court may grant such relief. A plaintiff must demonstrate:

- that it has suffered an irreparable injury;
- that remedies available at law, such as monetary damages, are inadequate to compensate for that injury;
- that, considering the balance of hardships between the plaintiff and defendant, a remedy in equity is warranted; and
- that the public interest would not be disserved by a permanent injunction.

These familiar principles apply with equal force to disputes arising under the Patent Act. As this Court has long recognized, “a major departure from the long tradition of equity practice should not be lightly implied.” Nothing in the Patent Act indicates that Congress intended such a departure. This approach is consistent with our treatment of injunctions under the Copyright Act.

Roberts CJ:

From at least the early 19th century, courts have granted injunctive relief upon a finding of infringement in the vast majority of patent cases. This “long tradition of equity practice” is not surprising, given the difficulty of protecting a right to *exclude* through monetary remedies that allow an infringer to *use* an invention against the patentee’s wishes—a difficulty that often implicates the first two factors of the traditional four-factor test. This historical practice, as the Court holds, does not *entitle* a patentee to a permanent injunction or justify a *general rule* that such injunctions should issue.

Kennedy J:

The cases now arising trial courts should bear in mind that in many instances the nature of the patent being enforced and the economic function of the patent holder present considerations quite unlike earlier cases. An industry has developed in which firms use patents not as a basis for producing and selling goods but, instead, primarily for obtaining licensing fees. For these firms, an injunction, and the potentially serious sanctions arising from its violation, can be employed as a bargaining tool to charge exorbitant fees to companies that seek to buy licenses to practice the patent. When the patented invention is but a small component of the product the companies seek to produce and the threat of an injunction is employed simply for undue leverage in negotiations, legal damages may well be sufficient to compensate for the infringement and an injunction may not serve the public interest.

C. THE NATURE OF AN INJUNCTION

6. *The object of an injunction:* The main object is to restrain apprehended future acts of infringement.

COFLEXIP SA v STOLT COMEX SEAWAY MS LTD

[2000] EWCA Civ 242

The court has under s 37 of the Supreme Court Act 1981 a general power to grant an injunction ‘in all cases in which it appears to the court to be just and convenient to do so.’ Section 61 of the Patents Act 1977 provides for ‘a claim for an injunction restraining the defendant ... from any apprehended acts of infringement.’ In so doing the section accords with the general law prior to the passing of that Act.

An injunction is a remedy against further injury and the court will not make the order if satisfied that no such injury is likely to occur. It is not because a defendant has done a wrong that an injunction will be granted against him. Where a patentee has conclusively established the validity of his patent and that it had been infringed, as a general rule an injunction will be granted.

However that will not happen as a matter of course as an injunction is a discretionary remedy. It is for that reason there have been cases where injunctions have been refused, for example, where the defendant satisfied the court that further infringement was not likely.

7. *Injunctions are concerned with future conduct:*

COFLEXIP STENA OFFSHORE LIMITED, COFLEXIP S.A.

[1999] EWHC Patents 258

Damages or an account of profits look to the past and are designed to compensate the plaintiff for the harm inflicted on him or to deprive the defendant of the benefit obtained by the activities performed in breach of the plaintiff's rights. The injunction looks to the future. Its purpose is to restrain threatened breaches of the plaintiff's rights. Normally, when a defendant has infringed, the court will assume it is not a one-off activity and will grant an injunction to stop repetition. This course is not inevitable. In a few cases courts have concluded that even though infringement has occurred, no future threat exists. In such cases, injunctive relief has been refused.

STAUFFER CHEMICALS v MONSANTO CO

1988 (1) SA 805 (T)²⁸⁵

The ordinary rules relating to interdicts apply [to patent cases]. Terrell correctly points out that the basis of an interdict is the threat, actual or implied, on the part of a defendant that he is about to do an act which is a violation of the plaintiff's right and that the actual infringement is merely evidence upon which the court implies an intention to continue in the same course. I would have thought it axiomatic that an interdict is not a remedy for past invasions of rights. It is for the protection of an existing right.

8. *General entitlement:* Having established the infringement of an IP right, the claimant is entitled to an injunction. Not all jurisdictions accept

285 Approved in *Philip Morris Inc v Marlboro Shirt Co SA Ltd* 1991 (2) SA 720 (AD).

the discretionary nature of the relief which enables a court to refuse an injunction once the infringement has been established and there is reason to believe that the respondent will continue with infringing.

LOUIS VUITTON MALLETIER SA v KNIERUM

[2004] FCA 1584 [Canada]

The true position is this. The basis for the grant of an injunction in an intellectual property case is in every respect the same as in any other case. The plaintiff must show that there is a risk that the defendant will engage in infringing conduct in the future. If the plaintiff is unable to make good that proposition, he will not obtain an injunction.

On the question of proof of the risk of repetition some judges have been prepared to infer that risk simply from past infringement. But the better view is expressed by Laddie J in *Coflexip SA v Stolt Comex Seaway MS Ltd* [1999] 2 All ER 592, where he said (at 605) that it is simply not right to treat [all intellectual property right] infringers as “bad apples”.

TELEMECANIQUE CONTROLS v SCHNEIDER ELECTRIC INDUSTRIES

2002 PTC (24) 632 [India]

It has to be appreciated that undoubtedly [a] patent creates a statutory monopoly protecting the patentee against any unlicensed user of the patented device. Thus once a violation is established in the case of a registered patent, subject of course to the patent being used, it will not be permissible to contend that the said patentee is not entitled to an injunction.

9. Discretionary remedy: The grant of an injunction is discretionary. This does not mean that a party may be denied its rights through the exercise of discretion unless there are special circumstances present.

NOKIA CORPORATION v TRUONG

[2005] FCA 1141 [Australia]

Permanent injunctions are granted conventionally in respect of cases of intellectual property infringement against proven infringement and a proven threat to continue infringing as this avoids multiplicity of proceedings. There is clear evidence that the respondents have continued to sell the infringing products, despite being aware of these proceedings, and the respondents have given no undertakings not to infringe. I therefore consider it appropriate to exercise my discretion to grant a permanent injunction.

10. *Damages as an alternative:* Although the grant of an injunction involves the exercise of the court's discretion, in exercising its discretion the court will, as a general rule, have regard to whether payment of damages without an injunction does not in fact compel the applicant to part with its rights. Because of this consideration, final injunctions have been granted as a matter of course (if the claimant has otherwise established its entitlement) in IP cases in most countries. Otherwise it could amount to granting the defendant a compulsory licence.²⁸⁶

D. FORM OF INJUNCTION

11. *Formulation:* Care should be taken in formulating an injunction.

COFLEXIP STENA OFFSHORE LIMITED, COFLEXIP S.A.

[1999] EWHC Patents 258

A defendant who has been enjoined must know what he can and cannot do. He should not be set a puzzle. As noted above, in most cases the precise outer limits of a patent claim are far from clear. This is confirmed, if any confirmation is necessary, by the numerous cases in which the finding on infringement arrived at by the High Court is reversed in the appellate courts. An injunction not to infringe a patent incorporates all this imprecision.

This need is vividly illustrated by the following judgment on appeal.

COFLEXIP SA v STOLT COMEX SEAWAY MS LTD

[2000] EWCA Civ 242

It is important that an order, such as an injunction, is drafted so as to set out, with such clarity as the context admits, what may not be done. It is for that reason that the standard form of injunction is in the terms restraining the defendant from infringing the patent. Such an injunction is limited in term and confined to the right given by s 60(1) and (2) of the Patents Act. It also excludes acts, carried out by the defendant and which fall within the ambit of the monopoly, but are excluded from infringement by the Act; for example private use coming within s 60(5)(a) of the Act.

Such an injunction is confined to the monopoly as claimed. The claim has been construed by the court with the aid of the parties

286 *R v James Lorimer & Co* [1984] 1 FC 1065 (CA).

and in the context of the acts alleged by the plaintiff to infringe and any other potentially infringing acts which the defendant wishes to bring before the court. Of course a dispute can arise as to whether acts, not brought before the court, amount to a breach of the injunction. But such a dispute arises against the background where the ambit of the claim and therefore the injunction has been the subject of consideration by the court and has been construed by it.

I turn next to consider the injunction which was granted at the judge's suggestion. It suffers from three basic deficiencies. First, as I have pointed out, it is not linked to the term during which the patent exists. That no doubt could be corrected by adding such words as "during the lifetime of the patent".

Second it exceeds the statutory right given by section 60(1) and (2) in that it fails to exclude acts which are, under the Act, excepted from the right. Third it raises considerable difficulties on construction.

The injunction granted by the judge has incorporated into it the "Defendants' Product and Process Description". That comprises three pages of typescript and four pages of diagrams. Such documents are normally produced, and this document appears to be no exception, to describe the alleged infringement in terms, using uncontroversial words, sufficient to enable the court to decide whether or not there was infringement. In this case it includes a considerable amount of detail which is irrelevant to infringement.

When deciding what is the appropriate form of injunction in a patent action it must be borne in mind that the injunction is being granted to prevent apprehended use of the patentees' statutory monopoly, as defined in his claim. The decision as to form is taken against the background of the claim having been construed by the court as between the parties. That of course does not happen in other intellectual property cases. An injunction which just restrained breach of confidence would not be appropriate for many reasons, including because the extent of the confidential information would not have been determined. In passing-off cases a change of circumstance can alter the representation made and therefore the injunction normally sets out the act which is to be prevented, qualified by such words as 'so as to pass-off'.

The judge seemed to believe that injunctions which restrained infringement of a patent were broad injunctions: but they equate to

the statutory right given, a right which has been held to have been validly granted and infringed. The injunction granted by the judge would allow the defendant to do other acts even though they may infringe. The defendant in those circumstances would be better off in that a change from that which is described and shown in the process description would allow him to continue in business without having to seek guidance from the court before adopting the change. The advantage to the defendant of only having the injunction cover a particular article or process is clear. If he makes a change he will not be in breach and it will be up to the patentee to bring another action. However the disadvantage to the patentee is equally clear. To obtain an injunction he has to establish his monopoly and that it has been infringed, and the judge must conclude that further infringement is apprehended. From his point of view, it is the infringer who should seek guidance from the court if he wishes to sail close to the wind. In the normal course of events that would be reasonable.

12. *Injunctions should be wide enough to provide proper protection:*

SPECTRAVEST INC v APERKNIT LTD

[1988] FSR 161

The ingenuity of those who infringe copyright and trade marks and engage in passing off is boundless, and plaintiffs cannot be adequately protected by orders which are cabined or confined. That is the reason for the standard forms of injunctions in such cases, with their inevitable references to “otherwise infringing”, “substantial part”, “to like effect”, “colorable imitation”, “otherwise passing off”. Where a defendant, faced with such an order, acts honestly and reasonably, this will mitigate and even excuse a breach of the order; but if a breach is proved, it will be for him to mitigate or justify it, and his excuse may need to be thoroughly probed if the circumstances are suspicious.

DAMAGES

CHAPTER XX

- A. INTERNATIONAL STANDARDS (1-3)
- B. DAMAGES: GENERAL (4-8)
- C. LOSS OF PROFITS (9-13)
- D. DEPRECIATION OF THE IP RIGHT (14)
- E. NOTIONAL ROYALTY (15-19)
- F. ACCOUNT OF PROFITS (20-25)
- G. STATUTORY DAMAGES (26)
- H. CONVERSION (27-28)
- I. PUNITIVE DAMAGES (29-32)

A. INTERNATIONAL STANDARDS

1. *The TRIPS Agreement*: The TRIPS Agreement requires of Member countries to provide in their laws for the recovery of damages in the case of IP infringement. Article 45 provides in this regard:

- Courts must be able to order the infringer to pay the right holder damages adequate to compensate for the injury the right holder has suffered because of an infringement of that person's IPR by an infringer who knowingly, or with reasonable grounds to know, engaged in infringing activity.
- Courts must also have the authority to order the infringer to pay the right holder expenses, which may include appropriate attorney's fees.
- In appropriate cases, Members may authorize courts to order recovery of profits and/or payment of pre-established damages even where the infringer did not knowingly, or with reasonable grounds to know, engage in infringing activity.

This recognizes the fact that the measure for damages in the case of the infringement of IP rights is often to be found in the relevant IP statute and that the law of a country may make the payment of damages dependent on knowledge of infringement or on negligence. Because the TRIPS obligations are minimum obligations a law may provide that an innocent infringer may be liable for damages.

2. *The European Union Directive*: The EU Directive on the Enforcement of Intellectual Property Rights of 29 April 2004²⁸⁷ requires of Member States to provide in their laws for the award of damages in IP cases and sets out minimum requirements. As will be seen, these requirements represent to a large extent the ruling principles. Article 13(1) reads as follows:

“Member States shall ensure that the competent judicial authorities, on application of the injured party, order the infringer who knowingly, or with reasonable grounds to know, engaged in an infringing activity, to pay the rightholder damages appropriate to the actual prejudice suffered by him/her as a result of the infringement.”

When the judicial authorities set the damages:

- they shall take into account all appropriate aspects, such as the negative economic consequences, including lost profits, which

²⁸⁷ The European Commission announced, in a communication of May 24, 2011, that this Directive No. 2004/48 would be reviewed in 2012 (see: http://ec.europa.eu/internal_market/copyright/docs/ipr_strategy/COM_2011_287_en.pdf).

the injured party has suffered, any unfair profits made by the infringer and, in appropriate cases, elements other than economic factors, such as the moral prejudice caused to the rightholder by the infringement or

- as an alternative [...], they may, in appropriate cases, set the damages as a lump sum on the basis of elements such as at least the amount of royalties or fees which would have been due if the infringer had requested authorisation to use the intellectual property right in question.”

3. *The general rule:* Unless the statute provides otherwise, the ordinary rules of law that determine the quantification of damages for statutory wrongs apply.

ARO MFG CO v CONVERTIBLE TOP REPLACEMENT CO

377 U.S. 476 [US Supreme Court]

[Damages] have been said to constitute “the difference between [the plaintiff’s] pecuniary condition after the infringement, and what his condition could have been if the infringement had not occurred.” The question to be asked in determining damages is “how much had the patent holder and licensee suffered by the infringement. And that question [is] primarily: had the infringer not infringed, what would the patent holder/licensee have made?”

The rule also applies in civil and mixed legal systems. For instance, according to Article 1382 of the French Civil Code any harmful wrongdoing must be compensated and according to Article 1149 compensation usually extends to the “lost profit” (*gain manqué, lucrum cessans*); and the loss suffered (*per te subie, damnum emergens*).

OMEGA AFRICA PLASTICS (PTY) LTD v SWISSTOOL MANUFACTURING CO (PTY) LTD

1978 (3) SA 465 (A) [South Africa]

Since the wrong is a species of delict, the measure will be delictual; it will be aimed at compensating the proprietor for his patrimonial loss, actual or prospective, sustained through the infringement.

B. DAMAGES: GENERAL²⁸⁸

4. *The problem of quantification:* Courts often have great difficulty in determining compensation for the infringement of IP rights. The problem

²⁸⁸ Reported damages cases are usually patent cases, but the principles are basically the same.

is not limited to ordinary civil courts – specialist IP courts are probably less qualified to determine questions relating to damages. And in the USA there is a right to a jury trial to quantify damages.²⁸⁹

The problem is not peculiar to patent or other IP litigation. In many fields (such as damages for personal injuries, professional negligence, breach of contract, and loss of profit and the like) quantification is a problem not only for the judiciary but also for the parties who have to present proof of causation and the extent of damages suffered.

In spite of the burden of proof, courts have a duty to assess damages even if it means that they have to make an estimate. The claimant has a duty to adduce the best available evidence of quantum and if that has been done, the court must apply the best estimate rule.²⁹⁰ Claimants often grossly overestimate the size of their loss with disastrous litigation costs consequences.²⁹¹

The issue of the calculation of damages is usually determined separately, after the issues of validity of the intellectual property right and of infringement have been decided. In some countries with an inquisitorial procedure, like France, the court on finding infringement appoints an expert to provide it with all the information necessary to assess damages.

5. Flexible approach: The law sometimes has a more flexible approach towards the question of damages, and compensation may be available which, strictly, compensates the plaintiff for more than the actual financial loss. These other methods will be discussed later in this chapter.

ATTORNEY GENERAL v BLAKE

[2000] UKHL 45 [UK]

So I turn to established, basic principles. I shall first set the scene by noting how the court approaches the question of financial recompense for interference with rights of property. As with breaches of contract, so with tort, the general principle regarding assessment of damages is that they are compensatory for loss or injury. The general rule is that, in the oft quoted words of Lord Blackburn, the measure of damages is to be, as far as possible, that amount of money which will put the injured party in the same position he would have been in had he not sustained the wrong. Damages are measured

289 *Feltner v Columbia Pictures Television Inc* (1998) 118 SCt 1279.

290 England: *Chaplin v Hicks* [1911] 2 KB 786; Canada: *Penvodic Contracting Co. Ltd. v. International Nickel Co. of Canada Ltd* (1975) 53 DLR (3d) 748. South Africa: *De Klerk v Absa Bank Ltd* [2003] 1 All SA 651 (SCA).

291 *General Tire v Firestone* [1976] RPC 197 [UK]; *Omega Africa Plastics (Pty) Ltd v Swisstool Manufacturing Co (Pty) Ltd* 1978 (3) SA 465 (A) [South Africa]; *Celanese International Corp v BP Chemicals Ltd* [1999] RPC 203 [UK].

by the plaintiff's loss, not the defendant's gain. But the common law, pragmatic as ever, has long recognized that there are many commonplace situations where a strict application of this principle would not do justice between the parties. Then compensation for the wrong done to the plaintiff is measured by a different yardstick.

6. *Statutory compensation:* It is consequently not only damages in the ordinary sense of the word that are recoverable in certain jurisdictions in the case of an IP infringement. Apart from the extended common-law approach towards the calculation of damages, legislatures (and the European directive) have realized that to require of plaintiffs to prove their damages in the ordinary manner may be unfair and they have devised alternative methods of calculating compensation. These other forms of monetary compensation will be dealt with below.

7. *The duty to present evidence:* Courts differ on whether or not damages may be presumed in trademark and passing off cases. It is however generally accepted that damages must be proved in patent, designs and copyright cases.

NISSAN CANADA INC v BMW CANADA INC

2007 FCA 255 [Canada]

With respect to the third component, i.e. damages, the trial judge accepted the respondents' argument that, once [infringement has been established], damages [whether nominal or substantial] are presumed [in a passing off case].

I find the trial judge erred in law in assuming that there would be damages. Actual or potential damage is a necessary element in finding liability. In the absence of evidence in this regard, the Court cannot conclude that there is liability. A plaintiff must "demonstrate that he suffers or, in a *quia timet* action, that he is likely to suffer damage by reason of the erroneous belief engendered by the defendant's misrepresentation that the source of the defendant's goods or services is the same as the source of those offered by the plaintiff".

A bifurcation order does not relieve the appellant from the necessity of proving the existence of damage as an element of his cause of action. It simply defers proof of the extent of the damage pending a determination as to the respondents' liability. In this case, there was no evidence before the trial judge demonstrating damages and no finding of damages. It was not open to the trial judge to presume damages.

TOMMY HILFIGER EUROPE v MCGARRY & ORS

[2008] IESC 36

Before considering what effect, if any, the correction of these errors may have I propose considering the basis upon which damages should be awarded for infringement of a registered Trade Mark and passing off. The position is the same in respect of each of the causes of action.

The object of an award of damages is to give to the plaintiff compensation for the damage or loss which he has suffered. Damage is divisible into pecuniary and non-pecuniary loss. The former comprises all financial loss such as loss of business profits or expenses incurred in a case such as the present. The latter in a case such as the present would include damage to reputation or goodwill and can be described as monetary compensation or reparation and takes the form of general as opposed to special damages as they do not admit of mathematical calculation.

The assessment of damages for infringement and passing off follow the same lines and both claims are frequently taken together with a single award being made: *Dormeuil Freres S.A. v Feraglow Limited* [1990] R.P.C. 449. The plaintiff need not show damage and the law presumes that any interference with goodwill by infringement or passing off will result in damage. However unlike other causes of action which are actionable *per se* the plaintiff is not restricted to purely nominal damages. In *Irvine & Ors v Talksport Limited* [2002] E.W.H.C. 539 the racing driver Eddie Irvine was awarded £2,000 damages. In *Antiebolaget Manus v Fullwood* [1954] 71 R.P.C. 243 the defendant had a substantial turnover in infringing goods in the period 1947 to 1950 the total exceeding £1.5 million. The plaintiff sought general damages based on the profits which the defendant had made on the basis of 10% of its turnover. The award for damages was £10,000 for infringement of Trade Marks and passing off. In this jurisdiction in *Falcon Travel Limited v Owners Abroad Group* [1991] I.R. 175, a passing off action based exclusively on presumed damage, the court refused an injunction and proposed to award damages in lieu and put the matter back for further evidence on the issue of damages. The court indicated that the award envisaged was a sum which would enable the plaintiff to advertise and re-establish its identity with the public and the trade.

As on the issue of damages the respondent relies on a number of copyright cases I should say now that I do not consider these relevant

as the basic measure of damages in such cases is the loss of profits caused by the diversion of customers to the defendant. There was no evidence of diversion given in this case and indeed the evidence was that no damage had been sustained by the respondents: in the absence of evidence it will not be assumed that the sales achieved by the defendant would necessarily have been obtained by the plaintiff: *Ledger Sons & Co. v J. Munro & Son Limited* [1916] 33 R.P.C. 53 and *P.C. Products Limited v Dalton* [1957] R.P.C. 199.

8. *The general rules in patent cases:*

ULTRAFRAME (UK) LTD v EUROCELL BUILDING PLASTICS LTD

[2006] EWHC 1344 (Pat) [UK]

The general principles to be applied in assessing damages for infringement of patent are now well established. So far as relevant to the present case, they can be summarized as follows:

- Damages are compensatory. The general rule is that the measure of damages is to be, as far as possible, that sum of money that will put the claimant in the same position as he would have been in if he had not sustained the wrong.
- The claimant can recover loss which was (i) foreseeable, (ii) caused by the wrong, and (iii) not excluded from recovery by public or social policy. It is not enough that the loss would not have occurred but for the tort. The tort must be, as a matter of common sense, a cause of the loss.
- The burden of proof rests on the claimant. Damages are to be assessed liberally. But the object is to compensate the claimant and not to punish the defendant.
- It is irrelevant that the defendant could have competed lawfully.
- Where a claimant has exploited his patent by manufacture and sale he can claim (a) lost profit on sales by the defendant that he would have made otherwise; (b) lost profit on his own sales to the extent that he was forced by the infringement to reduce his own price; and (c) a reasonable royalty on sales by the defendant which he would not have made.
- As to lost sales, the court should form a general view as to what proportion of the defendant's sales the claimant would have made.
- The assessment of damages for lost profits should take into account the fact that the lost sales are of extra production and that only certain specific extra costs (marginal costs) have been incurred in making the additional sales. Nevertheless, in practice

costs go up and so it may be appropriate to temper the approach somewhat in making the assessment.

- The reasonable royalty is to be assessed as the royalty that a willing licensor and a willing licensee would have agreed. Where there are truly comparable licenses in the relevant field these are the most useful guidance for the court as to the reasonable royalty. Another approach is the profits-available approach. This involves an assessment of the profits that would be available to the licensee, absent a licence, and apportioning them between the licensor and the licensee.
- Where damages are difficult to assess with precision, the court should make the best estimate it can, having regard to all the circumstances of the case and dealing with the matter broadly, with common sense and fairness.

C. LOSS OF PROFITS

9. *The primary rule:* As an IP right is income earning, the measure of damage is typically the loss of profits the proprietor sustained in respect of those infringing articles that he could and would have made and sold. Loss of profit is usually due to the fact that the owner sells fewer products, charges lower prices in order to compete with the infringer, or has increased production costs.²⁹²

GENERAL TIRE AND RUBBER CO v FIRESTONE TYRE AND RUBBER CO LTD

[1976] RPC 197 (HL)

One who infringes the patent of another commits a tort, the foundation of which is made clear by the terms of the grant. This, after conferring the monopoly of profit and advantage upon the patentee, concludes by declaring infringers 'answerable to the patentee according to the law for damages thereby occasioned.'

As in the case of any other tort (leaving aside cases where exemplary damages can be given) the object of damages is to compensate for loss or injury. The general rule at any rate in relation to "economic" torts is that the measure of damages is to be, so far as possible, that sum of money which will put the injured party in the same position as he would have been in if he had not sustained the wrong.

²⁹² John W Schlicher *Patent law: Legal and economic principles* § 9.04.

There are two essential principles in valuing that claim: first, that the plaintiffs have the burden of proving their loss: second, that, the defendants being wrongdoers, damages should be liberally assessed but that the object is to compensate the plaintiffs and not punish the defendants.

Many patents of inventions belong to manufacturers, who exploit the invention to make articles or products which they sell at a profit. The benefit of the invention in such cases is realized through the sale of the article or product. In these cases, if the invention is infringed, the effect of the infringement will be to divert sales from the owner of the patent to the infringer. The measure of damages will then normally be the profit which would have been realized by the owner of the patent if the sales had been made by him.

AMERICAN 21ST CENTURY FOX FILM INC. v BEIJING XIANKE LASER DISCS STORE
("XIANKE")

No.62-77 Intellectual Property Case in 1996 for the initial trial by No.1 Beijing Intermediate People's Court²⁹³

The plaintiffs' advocated that the defendants profit from selling the infringing products should be calculated without deduction of related selling costs and expenditures was reasonable and should be adopted by the Court.

Despite of the lack of related cases for selling infringing discs on record, it cannot be denied that the two stores did sell infringing discs. Therefore, the two defendants' misconduct for the exact sale volume cannot be determined and the related civil liability should be imposed on them consequently.

The plaintiffs' losses can be determined according to the profit, which the plaintiff could have earned from each infringing disc, and the supposed sale volume by the two stores. Apart from this, the plaintiffs were compensated for their attorney fees and other costs for action.

Different from other cases involving copyright infringement, the defendants' damages were determined according to a formula, within which the plaintiffs' loss equals to the sum of their prospective profit from each disc multiplied the two stores' sale volume, rather than according to the infringers' profit from the sale of infringing

discs. As a new method in determining damages for copyright infringement, it is used to provide the plaintiffs with a reasonable compensation, when the audit results show that the defense has incurred a loss or earned less profit due to the sale of infringing discs.

10. *Burden of proof:* What a claimant ordinarily has to prove is:

- the extent of the infringement (usually the quantity of infringing articles sold);
- the proportion of them that the claimant could and would have sold but for the infringement; and
- the profit the claimant would have made on the sale of those articles.²⁹⁴

Sometimes the rights holder does not market the goods but holds the rights as negative rights; sometimes the right relates to something that is not sold, such as a manufacturing method. In these cases the matter becomes even more complicated.

11. *Certainty about the quantum is not required:*

PARAMOUNT PICTURES CORPORATION v HASLUCK

[2006] FCA 1431[Australia]

I do not consider that where a basis for quantification of loss is entirely within the knowledge of the applicant and no evidence is adduced as to the quantum, the Court should make its own uninformed assessment of a royalty or license fee that the applicant might have foregone by reason of loss of sales. Speculation and even guesswork may have a role to play where the relevant evidence is inaccessible to the applicant. That is particularly so where the inadequacy of the evidence is caused by a recalcitrant or uncooperative respondent or one who has kept no adequate records of dealings.

COLOMBIA PICTURES INDUSTRY v ROBINSON

[1988] FSR 531 [UK]

To require certainty of proof that pirate marketing caused loss of sales would be impossible. Once it is shown that pirate marketing took place, some loss of legitimate sales may, in my view, properly be assumed. Where reasonable commercial expectations for the film in question are established in evidence and where, relatively to other

²⁹⁴ *Omega Africa Plastics (Pty) Ltd v Swisstool Manufacturing Co (Pty) Ltd* 1978 (3) SA 465 (A) 472. For the position in England: *Gerber v Lectra* [1995] RPC 383.

comparable films, the film has done poorly and where the presence of pirate copies upon the market has been established, the copyright owner is, in my judgment, entitled as against the pirate and in the absence of any other explanation for the lack of success of the film in question to attribute the shortfall in sales to the activities of the pirate.

12. Causation – the “but for” principle: The burden of proving causation is on the plaintiff. The plaintiff’s actual situation must be compared with a hypothetical situation, where infringement had not taken place. The difference is the damage but only insofar as the difference has actually been caused by the infringement.

RITE-HITE CORP v KELLEY CO

56 F3d 1538 [USA]

To recover lost profits damages, the patentee must show a reasonable probability that, *but for* the infringement, it would have made the sales that were made by the infringer. *Panduit Corp v Stahlin Bros Fibre Works Inc* 575 F2d 1152 (6th Cir 1978), articulated a four-factor test that has since been accepted as a useful, but non-exclusive, way for a patentee to prove entitlement to lost profits damages. The *Panduit* test requires that a patentee establish: (1) demand for the patented product; (2) absence of acceptable non-infringing substitutes; (3) manufacturing and marketing capability to exploit the demand; and (4) the amount of the profit it would have made. A showing under *Panduit* permits a court to reasonably infer that the lost profits claimed were in fact caused by the infringing sales, thus establishing a patentee’s *prima facie* case with respect to *but for* causation.

13. Reconstructing the market:

GRAIN PROCESSING CORP v AMERICAN MAIZE-PRODUCTS CO

185 F3d 1341 [USA]

To recover lost profits, the patent owner must show “causation in fact”, establishing that “but for” the infringement, he would have made additional profits. When basing the alleged lost profits on lost sales, the patent owner has an initial burden to show a reasonable probability that he would have made the asserted sales “but for” the infringement. Once the patent owner establishes a reasonable probability of “but for” causation, the burden then shifts to the accused infringer to show that the patent owner’s “but for” causation claim is unreasonable for some or all of the lost sales.

The “but for” inquiry therefore requires a reconstruction of the market, as it would have developed absent the infringing product, to determine what the patentee would have made.

Reconstructing the market, by definition a hypothetical enterprise, requires the patentee to project economic results that did not occur. To prevent the hypothetical from lapsing into pure speculation, this court requires sound economic proof of the nature of the market and likely outcomes with infringement factored out of the economic picture.

D. DEPRECIATION OF THE IP RIGHT

14. *Depreciation:* Damages may consist of, or include, the amount by which the relevant IP right has been depreciated by the infringement.²⁹⁵ The measure is sometimes used in copyright cases. Depreciation is however not an exclusive measure and is potentially misleading.

AUTODESK AUSTRALIA PTY LTD v CHARLES CHEUNG

(1990) AIPC 90-665 [Australia]

In *Sutherland Publishing Co Ltd v Caxton Publishing Co Ltd* [1936] 1 Ch 323 Lord Wright MR said that the measure of damages, in a copyright case, “is the depreciation caused by the infringement to the value of the copyright as a chose in action”. This formulation has often been cited in judgments. But it is a formulation to be applied with caution because it is potentially misleading. It will usually be difficult, often impossible, for a copyright owner to establish that a particular unauthorized reproduction has caused a diminution in the capital value of a copyright. There may be cases where this occurs, perhaps because of low quality reproductions or saturation of the market. But, on other occasions, unauthorized reproduction may actually increase the residual value of a copyright. For example, the unauthorized broadcasting of a song on radio may have the effect of increasing the demand for recordings of that song. No doubt, it is because of these matters that judicial warnings have sometimes been given against applying Lord Wright’s test too literally. Thus in *Interfirm Comparison v Law Society of New South Wales* (1975) 6 ALR 445 Bowen CJ in Eq. commented that it would be wrong to treat the measure of damages stated by Lord Wright as

295 Cf *Universal City Studios Inc v Mulligan (2)* [1999] IEHC 165 [Ireland].

“having, in effect, the force and rigidity of statutory provision. The purpose of damages is to compensate the plaintiff for the loss which he has suffered as a result of the defendant’s breach. It would, in my opinion, be wrong to regard it as the exclusive measure of damages for breach of copyright appropriate to all circumstances.”

E. NOTIONAL ROYALTY

15. *Basis of the relief:* Another device is to permit the plaintiff to claim a notional royalty from the defendant. In some jurisdictions it is a common-law measure of compensation while in others there is a statutory basis for it. The US Patent Act, for instance, provides that a claimant is entitled to damages that are not less than a reasonable royalty²⁹⁶ and the EU Directive has it as an option. (South African law: until legislative intervention, it was not regarded as available.)

In order to succeed, a plaintiff has to prove what in commercial practice a reasonable royalty rate is. This may give rise to difficulties of proof since in some industries licensing is uncommon. It has been said that this is the preferred method of calculating damages and is used in Germany in more than ninety percent of cases.²⁹⁷ The reason is fairly obvious: it is the method of calculation with the fewest risks. Doubt has been expressed about its application in trademark cases.²⁹⁸

CINCINATTI CAR CO v NEW YORK RAPID TRANSPORT CORP

66 F2d 592 [USA]

The whole notion of a reasonable royalty is a device in aid of justice, by which that which is really incalculable shall be approximated, rather than that the patentee, who has suffered an indubitable wrong, shall be dismissed with empty hands.

PUMA AG RUDOLF DASSLER SPORT v GLOBAL WARMING (PTY) LTD

(408/08) [2009] ZASCA 89

The court below, unnecessarily, expressed a view about Puma’s claim for a notional royalty, stating that the claim could not have succeeded in the absence of proof of actual loss. In this regard the court erred. The object of permitting a claim for damages in

296 35 USC §284.

297 BGH Case I ZR 87/07 – Zoladex 29 June 2009 [Germany].

298 *Reed Executive Plc & Ors v Reed Business Information Ltd & Ors* [2004] EWCA Civ 159 par 165.

the form of notional royalties is to obviate proof of actual loss, something extremely difficult to establish in intellectual property infringement cases. All a claimant has to prove is the number of infringing articles and the reasonable royalty rate.

16. *Calculating a reasonable royalty:*

GENERAL TIRE v FIRESTONE

[1976] RPC 197 (HL) [UK]

Other patents of inventions are exploited through the granting of licenses for royalty payments. In these cases, if an infringer uses the invention without a licence, the measure of the damages he must pay will be the sums which he would have paid by way of royalty if, instead of acting illegally, he had acted legally. The problem, which is that of the present case – the respondents not being manufacturers in the United Kingdom – is to establish the amount of such royalty. The solution to this problem is essentially and exclusively one of evidence, and as the facts capable of being adduced in evidence are necessarily individual, from case to case, the danger is obvious in referring to a particular case and transferring its conclusions to other situations.

The *Aluminium* case contains a clear statement by Sargant J:

“What has to be ascertained is that which the infringer would have had to pay if, instead of infringing the patent, he had come to be licensed under the patent. In doing that, it seems to me that the court is certainly not treating the infringer unduly harshly; he should at least, in my judgment, have to pay as much as he would in all probability have had to pay had he to deal with the patentee by way of free bargain in the way in which other persons who took licenses did in fact pay.”

These are very useful guidelines, but the principle of them must not be misapplied. Before a ‘going rate’ of royalty can be taken as the basis on which an infringer should be held liable, it must be shown that the circumstances in which the going rate was paid are the same as or at least comparable with those in which the patentee and the infringer are assumed to strike their bargain.

In some cases it is not possible to prove either that there is a normal rate of profit, or that there is a normal, or established, licence royalty. Yet clearly damages must be assessed. In such cases it is for the

plaintiff to adduce evidence which will guide the court. This evidence may consist of the practice, as regards royalty, in the relevant trade or in analogous trades; perhaps of expert opinion expressed in publications or in the witness box; possibly of the profitability of the invention; and of any other factor on which the judge can decide the measure of loss.

- 17.** *The fact that comparable licenses are not known does not mean that the court should determine a reasonable rate:*

BLAYNEY (T/A AARDVARK JEWELRY) v CLOGAU ST DAVID'S GOLD MINES LTD

[2002] EWCA Civ 1007

In my view it is clear that damages have been recoverable in respect of all infringements whether proved to have resulted in lost sales or not. The relevance of lost sales is to enable the court to assess the damages by reference to lost profits; it is not a limitation on the recoverable loss.

Given that that is the rule in the case of infringements of patents I can see no reason not to apply it in cases of infringements of copyright. In each case the infringement is an interference with the property rights of the owner. Though the nature of the monopoly conferred by a patent is not the same as that conferred by copyright I see no reason why that should affect the recoverability of damages in cases where the monopoly right has been infringed. The fact that the plaintiff may not be able to prove the application of one measure of damages, namely lost sales, does not mean that he has suffered no damage at all, Rather some other measure by which to assess the compensation for that interference must be sought. Whilst, no doubt, there are differences between the rights granted to a patentee and those enjoyed by the owner of the copyright they draw no distinction between the effect of an infringement of a patent rather than a copyright.

In *SPE International Ltd v Professional Preparation Contractors (UK) Ltd* [2002] EWHC 881 (Ch) Rimer J was faced with a similar problem. Rimer J then said

“The absence of any evidence as to a relevant licensing arrangement does not mean that such an arrangement is an impossible one. In principle, I can see no reason why a notionally willing licensor and a like licensee should not come to an arrangement for the licensing of a shot blasting machine

in consideration of the payment of a royalty calculated on some appropriate basis. The fact that there is no solid evidence that this has been done before does not mean that it cannot be done at all. Equally, if someone makes an unauthorized use of another's machine for his own purposes, I can see no good reason why he should not pay proper compensation for the damage occasioned to the other's property right by the unlawful use so made. Compensation by reference to a notional fee for the unauthorized use would, in my view, ordinarily be regarded as a fair and proper basis on which to provide compensation. For the court to refuse any compensation at all simply because there was no evidence that machines of that sort had ever been licensed out for a royalty would appear to me to involve a denial of justice."

PARAMOUNT PICTURES CORPORATION v HASLUCK

[2006] FCA 1431 [Australia]

I do not consider that where a basis for quantification of loss is entirely within the knowledge of the applicant and no evidence is adduced as to the quantum, the Court should make its own uninformed assessment of a royalty or licence fee that the applicant might have foregone by reason of loss of sales. Speculation and even guesswork may have a role to play where the relevant evidence is inaccessible to the applicant. That is particularly so where the inadequacy of the evidence is caused by a recalcitrant or uncooperative respondent or one who has kept no adequate records of dealings.

18. *US approach:* The difference between the English and the USA in relation to notional royalties is the fact that in the US the entitlement is based on statute, as also in South Africa. The reasonable royalty rate assumes a willing licensor-licensee determination. The infringer must be allowed a reasonable profit margin in this calculation.

GEORGIA-PACIFIC CORP v US PLYWOOD-CHAMPION PAPERS

446 F2d 295 [USA]

The statutory authority for the district court's award was 35 USC § 284, which provides in relevant part that the court shall award the claimant damages adequate to compensate for the infringement, but in no event less than a reasonable royalty for the use made of the invention by the infringer.

The parties seem in essential agreement that the trial court correctly chose to apply the 'willing buyer-willing seller' rule in determining

a reasonable royalty under that section. This rule contemplates a suppositious meeting in advance of infringement between patent owner and potential infringer in order to work out a license agreement.

The trial court found a wide range of factors relevant in such hypothetical negotiations and carefully considered whether there was competition between USP's [the plaintiff's] product (Weldtex) and other kinds of paneling; the effect of both the cyclical popularity of specialty plywoods and the short time the patent had to run; USP's profits on sales of Weldtex and collateral sales of other products occasioned by sales of Weldtex; GP's [the defendant's] expected profits on both striated plywood and collateral sales; the importance of the Deskey patent relative to other processes necessary for producing the plywood and Weldtex's decorative quality; and whether there were comparable prevailing royalties on either Weldtex or similar products.

While we sustain all of the trial court's basic findings, we modify its ultimate conclusion as to a reasonable royalty because we think it fails to leave GP [the infringer] a reasonable profit on its sale of striated plywood.

The size of an infringer's profits is often an influential factor in the determination of the amount of a reasonable royalty. In fact, the very definition of a reasonable royalty assumes that, after payment, the infringer will be left with a profit.

19. *The position in Japan:*

CASE NUMBER: 2004(WA) NO.12032

Osaka District Court, 26th Civil Division

The court mentioned that, in general, there may be various ways to decide how to pay a royalty under a trademark license contract between the trademark holder and the licensee, and the parties were free to choose one by agreement. The court then concluded that although such an agreement might not always exist in the case of trademark infringement, it was appropriate to calculate the amount of reasonable royalty by determining a monthly rate multiplied by the number of months during which the infringement continued, unless the calculation method thus argued was particularly unreasonable.

The court explained that the amount of reasonable royalty per unit period should be decided by taking into consideration various

factors concerned, including the value of the trademark, the actual circumstances of transactions, and the details of the infringement. The court calculated the amount of damage taking into consideration the royalty rate usually imposed by a plaintiff on a third party for a non-exclusive license (whether or not and to what extent the trademarks were well known) and how the defendant used the marks.

F. ACCOUNT OF PROFITS

20. *Difference between accounts and loss:* The profit made by the defendant is seldom equivalent to the plaintiff's loss. Some jurisdictions allow a claimant to claim the infringer's gain by means of an account of profits. The Canadian Copyright Act is specific in this regard (s 35(1)):

Where a person infringes copyright, the person is liable to pay such damages to the owner of the copyright as the owner has suffered due to the infringement and, in addition to those damages, such part of the profits that the infringer has made from the infringement and that were not taken into account in calculating the damages as the court considers just.

The defendant is treated as if it conducted its business on behalf of the rights holder. The claimant usually has to make an election between this remedy and claiming its actual loss. The maximum payment that can be ordered is the total profit made by the defendant.²⁹⁹ But then it remains necessary to prove causation, i.e., that the profit was made as a result of the infringement.

This remedy is not available in countries such as France³⁰⁰ or South Africa³⁰¹ because it is in conflict with the ordinary civil-law rule that a harmed party is only entitled to be compensated to the extent of its loss. However, it is now available in Germany and Dutch law provides that in addition to claiming damages, the author or his successor in title may request the court to order anyone who has infringed the copyright to hand over the profits originating from the infringement and to render account therefor.

299 In England: *Celanese International Corp v BP Chemicals Ltd* [1999] RPC 203 218 et seq. In Canada: *Imperial Oil v Lubrizol* [1996] 71 CPR (3d) 26.

300 Court of Appeal Paris, 4th chamber, 22 February 1963, Ann. P.I 1963, p. 377, TGI Seine, 3rd chamber February 1964, JCP Ed. G, 1965, 14334, note Plaisant.

301 *Montres Rolex SA v Kleynhans* 1985 (1) SA 55 (C).

CASE I ZR 87/ 07 ZOLADEX (GERMANY)

In order to give effect to the idea of balancing in the calculation of damages with reference to the profit made by the infringer it is assumed that the owner of the right would have made the same profit which the infringer made.³⁰²

- 21.** *The claim for account of profit is for compensation and not for actual loss:*

ATTORNEY GENERAL v BLAKE

[2000] UKHL 45 [UK]

A property right has value to the extent only that the court will enforce it or award damages for its infringement. The question under discussion is whether the court will award substantial damages for an infringement when no financial loss flows from the infringement and, moreover, in a suitable case will assess the damages by reference to the defendant's profit obtained from the infringement. The cases mentioned above show that the courts habitually do that very thing.

- 22.** *This method of claiming compensation is fraught with danger:*

SIDDELL v VICKERS

(1892) 9 RPC 152 [UK]

The plaintiff therefore was perfectly within his right in electing, as he did in this case, to have an account of profits; but I do not know any form of account which is more difficult to work out, or may be more difficult to work out than an account of profits. The difficulty of finding out how much profit is attributable to any one source is extremely great – so great that accounts in that form very seldom result in anything satisfactory to anybody. The true test of comparison is to take the ratio of profit derived when the invention was used to the profit which would have been derived had the defendant used that which, looking at all the circumstances of the case, he would most probably have used had he not illegally adopted the invention.

- 23.** *The award depends on the defendant's profits:* The inventor is only entitled to that portion of the infringer's profit which is causally attributable to the invention.

³⁰² Um dem Ausgleichsgedanken Rechnung zu tragen, wird bei der Bemessung des Schadensersatzes anhand des Verletzergewinns gerade fingiert, dass der Rechtsinhaber ohne die Rechtsverletzung durch Verwertung seines Schutzrechts den gleichen Gewinn erzielt hätte wie der Verletzer.

MONSANTO CANADA INC v SCHMEISER

[2004] 1 SCR 902 [Canada]

The Patent Act permits two alternative types of remedy: damages and an accounting of profits. Damages represent the inventor's loss, which may include the patent holder's lost profits from sales or lost royalty payments. An accounting of profits, by contrast, is measured by the profits made by the infringer, rather than the amount lost by the inventor. Here, damages are not available, in view of Monsanto's election to seek an accounting of profits.

It is settled law that the inventor is only entitled to that portion of the infringer's profit which is causally attributable to the invention. This is consistent with the general law on awarding non-punitive remedies: '[I]t is essential that the losses made good are only those which, on a common sense view of causation, were caused by the breach'.

The preferred means of calculating an accounting of profits is what has been termed the value-based or 'differential profit' approach, where profits are allocated according to the value contributed to the defendant's wares by the patent. A comparison is to be made between the defendant's profit attributable to the invention and his profit had he used the best non-infringing option.

24. *Knowledge of infringement is often required for liability:* It lies upon a plaintiff who seeks an account of profits at common law to establish that profits were made by the defendant knowing that he was transgressing the plaintiff's rights.

COLBEAM PALMER LTD v STOCK AFFILIATES PTY LTD

(1968) 122 CLR 25 (HCA) [Australia]

And the account of profits retains the characteristics of its origin in the Court of Chancery. By it a defendant is made to account for, and is then stripped of, profits he has made which it would be unconscionable that he retain. These are profits made by him dishonestly, that is by his knowingly infringing the rights of the proprietor of the trademark. This explains why the liability to account is still not necessarily coextensive with acts of infringement. The account is limited to the profits made by the defendant during the period when he knew of the plaintiff's rights. So it was in respect of common law trademarks. So it still is in respect of registered trademarks. I think that it follows that it lies upon a plaintiff who seeks an account of profits to establish that profits were made by the defendant knowing that he was transgressing the plaintiff's rights.

25. *The meaning of profit:* The problem arises as to how profits are to be ascertained, especially in the case where the product sold is a composite one. The profits may then be apportioned, depending on what was appropriated.³⁰³

COLBEAM PALMER LTD v STOCK AFFILIATES PTY LTD

(1968) 122 CLR 25 (HCA)

What the defendant must account for is what it made by its wrongful use of the plaintiffs' property. The plaintiffs' property is in the mark, not in the painting sets. The true rule, I consider, is that a person who wrongly uses another man's industrial property – patent, copyright, trademark – is accountable for any profits which he makes which are attributable to his use of the property which was not his.

Lord Kinnear in the Court of Session in Scotland sufficiently summarized the course of earlier decisions when he said "and there certainly is a great deal of authority for saying that where only a part of a complex machine is protected by a patent, the infringer cannot be made liable for the aggregate profit derived from the entire machine, as if that were the profit he had made by the use of the patent". And in the same case on appeal Lord Watson said that in a patent action, if the patentee elects to have profits instead of damages,

"it becomes material to ascertain how much of his invention was actually appropriated, in order to determine what proportion of the net profits realized by the infringer was attributable to its use. It would be unreasonable to give the patentee profits which were not earned by the use of his invention."

In trademark cases it has been generally accepted that what a plaintiff who establishes infringement is entitled to is the profit attributable to the use of the mark, and no more.

CASE NUMBER: 2005(WA) NO.3126 [2005.12.1]

Osaka District Court, 21th Civil Division [Japan]

The profits obtained by the infringer from the act of infringement may be calculated by deducting from the sales generated by the infringer's act of selling the infringing products the costs incurred by the infringer for the sale of the infringing products. The costs

303 See also *Dart Industries Inc v Décor Corporation Pty Ltd* (1993) 179 CLR 101 [Australia].

subject to the deduction are only those that the infringer had to additionally incur to sell the infringing products. Any costs that fall under that category may be subject to the deduction. Those costs may include not only the purchasing cost and the cost of goods sold but also the selling cost and the general administrative cost.

G. STATUTORY DAMAGES

26. Fixed compensation. Pre-established or statutory damages offer “an alternative and perhaps more effective way to compensate right holders and provide them with an expedient and economical way to prove and recover the damage suffered through counterfeiting and piracy.”³⁰⁴ Some lawgivers in an attempt to assure that rights holders receive their just recompense have done just that. For instance, the US Copyright Act (s 504(c)) gives the court a discretion to award a plaintiff up to \$30 000 with respect to one copyrighted work and \$150 000 if the court finds that the infringement was willful. In *Playboy Enterprises Inc v San Filippo*³⁰⁵ the plaintiff sought, using the formula, damages of \$285m for the sale of a few thousand CDs with infringing photographs, but the court awarded \$3,7m. Since this is a matter of local law it will not be pursued here any further.

H. CONVERSION

27. The nature of the remedy. Conversion, as a remedy for copyright infringement, is regulated by statute in many countries and works on the assumption that the rights holder is the owner of the infringing article.

POLYGRAM PTY LTD v GOLDEN EDITIONS PTY LTD

[1997] FCA 687 [Australia]

The owner of a copyright whose work has been infringed may recover compensatory damages and, by way of special remedy, additional damages. Section 116 confers a right to recover infringing copies or damages for conversion of those copies. A copyright owner’s rights and remedies under s 116 are those which may be asserted in an action for conversion or detention. The hypothesis on which the remedy is conferred by s 116 is that the copyright owner is not the owner of the infringing copy, but is treated by a fiction, created by

304 *Synthesis of issues concerning difficulties and practices in the field of enforcement* IPO/CME/3 par 55.

305 (1998) 46 USPQ 2d 1350 [USA].

the section, of being entitled to sue for damages for conversion or detention as if he or she were the owner of the infringing copy.

The measure of damages in conversion is generally the value of the infringing copy at the date of conversion. Conversion damages are awarded on the basis that the infringing copy is deemed to be the property of the copyright owner.

28. *Conversion in the case of a composite article:* The dispute concerned the measure in the case of a composite article such as the use of a copyright drawing on a T-shirt or a trademark on a football.

POLYGRAM PTY LTD v GOLDEN EDITIONS PTY LTD

[1997] FCA 687

In my view, when the issue is whether an article satisfies the definition of infringing copy, the task of the court is to decide whether the making of that article constituted an infringement of the work. If the court is presented with goods that comprise infringing and non-infringing matter, it will be necessary to decide whether the goods can be severed into infringing and non-infringing components.

If the goods can be severed then the court can find that it was the making of the infringing component that constituted an infringement of the work, and therefore that the infringing copy is only comprised by that component. In such a case the copyright owner is only entitled to damages that represent the value of the copyright material taken.

If the goods cannot be severed then the court will find that it was the making of both components that constituted an infringement of a work, and therefore the infringing copy consists of both components. In such a case the copyright owner is entitled to damages that represent the value of the whole goods.

I. PUNITIVE DAMAGES

29. *Common-law punitive damages:* Punitive damages are available in some common-law jurisdictions against a deliberate infringer who has behaved in a particularly appalling manner.³⁰⁶

306 David Vaver, *Intellectual Property Law* (1997) 263.

LUBRIZOL CORP v IMPERIAL OIL LTD

1996 CanLII 4042 [Canada]

It is now clear that Canadian law recognizes three distinct types of damages. First, there are general or compensatory damages, which are meant to reimburse a victim of wrongdoing for any losses suffered, both pecuniary and non-pecuniary. Second, there are aggravated damages, which are also compensatory, but which may be awarded only in cases where “defendants’ conduct has been particularly high-handed or oppressive, thereby increasing the plaintiff’s humiliation and anxiety”.

Third, punitive or exemplary damages, unlike general and aggravated damages, are not compensatory; their aim is “to punish” a defendant and to express “outrage at the egregious conduct of the defendant”. They are akin to a civil fine which is meant to “act as a deterrent to the defendant and to others from acting in this manner”. Exemplary damages may be awarded only “where the combined award of general and aggravated damages would be insufficient to achieve the goal of punishment and deterrence”. In addition, it is necessary for such an award to “serve a rational purpose”, that is, “was the misconduct of the defendant so outrageous that punitive damages were rationally required to act as deterrence”?

The standard of proof in punitive or exemplary damage cases is the civil standard of proof on the balance of probabilities, not the criminal standard of proof beyond a reasonable doubt. Nevertheless, an award of exemplary damages should always receive the most careful consideration and the discretion to award them should be most cautiously exercised. Furthermore, the *quantum* awarded should not be excessive, but should be reasonable, in keeping with the Canadian experience in the award of relatively modest punitive damages.

TIME INCORPORATED v LOKESH SRIVASTAVA

2005 (30) PTC 3 [India]³⁰⁷

Coming to the claim of punitive and exemplary damages for the flagrant infringement of the plaintiff’s trade mark, this Court is of the considered view that a distinction has to be drawn between compensatory damages and punitive damages. The award of compensatory damages to a plaintiff is aimed at compensating him for the loss suffered by him whereas punitive damages are aimed at deterring a wrong doer and the like minded from indulging in

307 Quoted with approval in *Hero Honda Motors Ltd v Shree Assuramji Scooters* 2006 (32) PTC 117 [India].

such unlawful activities. Whenever an action has criminal propensity also the punitive damages are clearly called for so that the tendency to violate the laws and infringe the rights of others with a view to make money is curbed. The punitive damages are founded on the philosophy of corrective justice and as such, in appropriate cases these must be awarded to give a signal to the wrong doers that law does not take a breach merely as a matter between rival parties but feels concerned about those also who are not party to the lis but suffer on account of the breach.

This Court has no hesitation in saying that the time has come when the Courts dealing actions for infringement of trade marks, copyrights, patents, etc. should not only grant compensatory damages but award punitive damages also with a view to discourage and dishearten law breakers who indulge in violations with impunity out of lust for money so that they realize that in case they are caught, they would be liable not only to reimburse the aggrieved party but would be liable to pay punitive damages also, which may spell financial disaster for them. In *Mathias v. Accor Economi Lodging, Inc.*, 347 F.3d 672 (7th Cir. 2003) the factors underlying the grant of punitive damages were discussed and it was observed that one function of punitive damages is to relieve the pressure on an overloaded system of criminal justice by providing a civil alternative to criminal prosecution of minor crimes. It was further observed that the award of punitive damages serves the additional purpose of limiting the defendant's ability to profit from its fraud by escaping detection and prosecution.

30. *Statutory punitive damages:* Typical in common-law countries is a provision in copyright laws that provides for additional damages.³⁰⁸ It is available in the case of flagrancy, which implies "the existence of scandalous conduct, deceit and such like; it includes deliberate and calculated copyright infringement."³⁰⁹

MICROSOFT CORPORATION v GOODVIEW ELECTRONICS PTY LIMITED

[2000] FCA 1852 [Australia]

The applicants claim that additional damages should be awarded under s 115(4) of the Copyright Act to take into account the 'calculated and deliberate' nature of the infringements by the respondents. Section 115(4) provides that, where an infringement

308 US law, which is not typical in this regard, permits a court to increase the award up to three times the actual damages. 35 USC §284.

309 *Ravenscroft v. Herbert* (1980) RPC 193; *MJA Scientifics International Pty Ltd v SC Johnson & Son Pty Ltd* (1998) 43 IPR 275.

of copyright is established, the court may award additional damages if it is satisfied that it is proper to do so, having regard to:

- the flagrancy of the infringement;
- any benefit shown to have accrued to the defendant by reason of the infringement; and
- all other relevant matters.

For the purposes of s 115(4), flagrant conduct will include conduct that is “deliberate, deceitful and serious”. The structure of s 115(4), however, demonstrates that it is not necessary to establish that a breach demonstrates a particular degree of flagrancy in order for additional damages to be awarded. That is, flagrancy is not a threshold which must be crossed, but merely one of the factors to be taken into account in calculating an award of damages.

In the present case, the conduct of the respondents can properly be described as flagrant in the sense referred to above. A defence filed in these proceedings alleged that all of its Microsoft products were acquired from authorized dealers. This was proved to be false. Internal documents of the respondents evinced an intention to conceal the identity of their suppliers through the use of cash purchases of infringing copies and a system of code names for suppliers. In combination, these actions demonstrate a deliberate pattern of conduct by the respondents in which they recognized the illegality of the enterprise they were engaged in and actively sought to conceal it.

The respondents have benefited financially from the sale of infringing copies of various Microsoft products. These products were purchased well below the wholesale price for genuine Microsoft products and sold for a slight discount on the retail price. The profit margin created by the respondents was substantial in a very competitive industry.

In considering an award of additional damages under s 115(4), I also have regard to the considerations referred to by Wilcox J in *Autodesk Australia Pty Ltd v Cheung* (1990) 17 IPR 69. That case also involved infringement of copyright in computer software, and his Honor considered it relevant to take into account the fact that computer software is easy to duplicate, distribute and conceal. This makes detection and proof of infringement a substantial task.³¹⁰

310 The full quotation reads: “Turning to sub-para.(iii), one matter which is, in my opinion, relevant, is the difficulty computer program owners face in trying to protect their copyrights. Computer software is easy to duplicate, distribute and conceal. Particularly in a case where a person is supplying computer programs as an adjunct to other equipment, and is therefore not advertising the supply, infringements may be difficult to detect. And, when they are detected, proof of the facts may be a substantial task.”

In the circumstances it is appropriate for damages to be awarded under s 115(4). The court has a broad unilateral discretion in relation to the quantum of additional damages. I regard this as a strong case for an award of additional damages. The respondents acted with a calculated disregard for the applicant's rights in the pursuit of profits. I consider that additional damages in the sum of \$500,000 will sufficiently indicate the court's disapproval of the conduct of the respondents. The respondents will be jointly and severally liable for the additional damages.

WELLINGTON NEWSPAPERS v DEALERS GUIDE

(1984) 4 IPR 417 [New Zealand]³¹¹

What is flagrant must of course be a question of fact and degree to be decided against the background of relevant facts.

The additional damages are to be awarded where the court is satisfied that the remedies otherwise provided by the section for an action brought under it do not provide effective relief. This would suggest that there may be some damage or loss suffered by a plaintiff which compensatory damages, injunction, the taking of accounts or other remedy would not assuage. It is difficult to see what is contemplated by the additional damage unless it is something in the nature of punishment to the defendant for the hurt done to the plaintiff which the conventional remedies would not provide. How otherwise would the flagrancy of the infringement be relevant? This is indeed how the equivalent English subsection has been interpreted. In *Ravenscroft v Herbert* [1980] RPC 193 (Ch) Brightman, J said

“To entitle the plaintiff to such additional damages it must be established that effective relief would not otherwise be available to the plaintiff giving regard to the flagrancy of the infringement, any benefit shown to have accrued to the defendant by reason of the infringement, and other material considerations.”

MICROSOFT CORPORATION v PC CLUB AUSTRALIA PTY LTD

[2005] FCA 1522 [Australia]

An assessment of the amount of additional damages, which the applicants sought to obtain in principle, was described by the applicants as a “jury” question; and that in an appropriate

311 Quoted in *Microsoft Corporation v Able System Development Ltd* HCA 17892/1998 [Hong Kong 2002].

case, the quantification thereof may well exceed the amount of compensatory damages.

Of course each case must be viewed in the light of its own circumstances, but the foregoing evident margins between compensatory damages and additional damages are not without significance in terms of a principled approach to assessment.

I record again the factors which the applicants identified as giving rise to their entitlement for [additional] damages: (i) flagrancy; (ii) a false defense as to acquisition from authorized dealers; (iii) a deliberate pattern of conduct in which the respondents engaged in deliberate infringements which they sought to conceal; (iv) the evident rewards, including trading advantages inherently gained from the respondents' misconduct, directly or indirectly. (v) the relative ease by which computer software may be duplicated, distributed and concealed, thereby rendering detection and proof of infringement a substantial task. Each of those elements is in my opinion clearly here present.

[The award under this head was substantial.]

31. *The object is to punish:*

WELLINGTON NEWSPAPERS LTD v DEALERS GUIDE LTD

[1984] 4 IPR 417 [New Zealand]

It is difficult to see what is contemplated by the additional damage unless it is something in the nature of punishment to the defendant for the hurt done to the plaintiff which the conventional remedies would not provide. How otherwise would the flagrancy of the infringement be relevant?

32. *Willfulness:* Some statutes require proof of willfulness before punitive damages may be imposed on a defendant. And others provide that a defendant "'in proceedings for infringement of a patent damages shall not be awarded, and no order shall be made or an account of profits, against a defendant or defender who proves that at the date of the infringement he was not aware, and had no reasonable grounds for supposing, that the patent existed."³¹²

312 E.g. UK Patents Act 1977 s 62(1).

KNORR-BREMSE v DANA CORP

383 F3d 1337 [USA]

In discussing “willful” behavior and its consequences, the Supreme Court has observed that “[t]he word willful is widely used in the law, and, although it has not by any means been given a perfectly consistent interpretation, it is generally understood to refer to conduct that is not merely negligent.” The concept of ‘willful infringement’ is not simply a conduit for enhancement of damages; it is a statement that patent infringement, like other civil wrongs, is disfavored, and intentional disregard of legal rights warrants deterrence.

Determination of willfulness is made on consideration of the totality of the circumstances and may include contributions of several factors. These contributions are evaluated and weighed by the trier of fact, for, as this court remarked in *Rite-Hite Corp v Kelley Co* 819 F2d 1120,

“willfulness in infringement, as in life, is not an all-or-nothing trait, but one of degree. It recognizes that infringement may range from unknowing, or accidental, to deliberate, or reckless, disregard of a patentee’s legal rights.”

CRIMINAL ENFORCEMENT OF IP RIGHTS

CHAPTER XXI

- A. INTRODUCTION (1-9)
- B. THE SOURCE OF THE OBLIGATION TO CRIMINALIZE (10-12)
- C. THE REASONS FOR CRIMINAL SANCTIONS (13-23)
- D. THE FINANCIAL IMPACT OF COUNTERFEITING (24-31)
- E. REASONS FOR THE PREVALENCE OF COUNTERFEITING (32-36)
- F. THE SUCCESS OF CRIMINAL SANCTIONS (37-38)
- G. PROCEEDS OF CRIME LEGISLATION (39-40)
- H. THE DECISION TO PROSECUTE (41-42)
- I. LIABILITY OF ACCESSORIES (43-48)
- J. COUNTERFEITING IN THE INTERNET AGE (49-51)

A. INTRODUCTION

1. *Introduction:* The section of this work dealing with criminal enforcement is not entirely case-law based. The reason is that there are but a few reported cases on this subject, mainly because criminal enforcement cases are usually dealt with in lower criminal courts and they seldom reach higher courts. This means that these cases are not reported in law reports.³¹³

2. *Counterfeiting is an age-old problem:* Part of the fame of Archimedes (287 - 212BCA) rests on his discovery of the principle that bears his name. His king had ordered a gold crown but suspected that the crown delivered by the goldsmith was counterfeit containing silver. Having struck the answer in his bathtub, Archimedes is reputed to have run nakedly into the street, calling "Eureka, eureka" (I have found it, I have found it).

Concern about the quality of drugs is as old as drugs themselves, says the World Health Organization. Writings from as early as the 4th century BCE warn about the dangers of adulterated drugs and, in the 1st century CE, Dioscorides, a celebrated Greek physician, botanist, pharmacologist and surgeon, who traveled with the armies of the Roman Emperor Nero, identified fake herbal drugs in his *De Materia Medica*, the precursor of modern pharmacopeias, and advised on their detection.

3. *The problem persists:*³¹⁴ The World Health Organization, within the framework of its International Medical Products Anti-Counterfeiting Task Force (IMPACT)³¹⁵ defines counterfeit medicine as

"a medicine, which is deliberately and fraudulently mislabelled with respect to identity and/or source. Counterfeiting can apply to both branded and generic products and counterfeit products may include products with the correct ingredients or with the wrong ingredients, without active ingredients, with insufficient active ingredients or with fake packaging."

As we shall see, this definition is wider than the one that applies to IP law.

313 For a general discussion see Duncan Matthews *The fight against counterfeiting and piracy in the bilateral trade agreements of the EU* – a briefing paper requested by the European Parliament's Committee on International Trade (2008).

314 See also Directive 2011/62/EU of the European Parliament and of the Council of 8 June 2011 amending Directive 2001/83/EC on the Community code relating to medicinal products for human use, as regards the prevention of the entry into the legal supply chain of falsified medicinal products.

315 In January 2012, the WHO Executive Board agreed to propose to the WHO General Assembly the establishment of a new mechanism - that would *de facto* supersede IMPACT - for international collaboration on counterfeit and substandard medical products, though excluding trade and intellectual property issues – see http://apps.who.int/gbl/ebwhalpdf_files/EB130/B130_R13-en.pdf.

4. *Counterfeiting relates to trademarks*: Although the term “counterfeiting” is used with reference to unauthorized appropriation of a variety of different types of intellectual property, only in the trademark area is the term technically accurate.³¹⁶ A trademark, which cannot be distinguished in its essential aspects from a registered trademark, and thereby infringes the rights of the owner of the trademark in question, is a counterfeit trademark.
5. *Pirating relates to copyright*: Pirating, on the other hand, concerns copyright. Commonly, it refers to clear-cut unauthorized infringement of printed works, sound recordings, audio-visual works, and computer software. Pirated copyright goods are copies made without the consent of the right holder and which are made directly or indirectly from an article where the making of that copy would have constituted an infringement of a copyright or a related right.

R v JOHNSTONE

[2003] UKHL 28 [UK]

Counterfeit goods and pirated goods are big business. Counterfeit goods comprise cheap imitations of the authentic article, sold under the trademark of the authentic article, as with imitation ‘Rolex’ watches.

Pirated goods comprise illicit copies of the authentic article which are not sold under the trademark of the authentic article. This would happen, for instance, when a person makes and sells unauthorized copies of computer software which is the subject of copyright. Thus, in the context of music recordings, a counterfeit compact disc is an unlawful copy of, say, a Virgin compact disc sold ostensibly as a Virgin product. A pirated compact disc is an unlawful copy of, in my example, a Virgin compact disc which is sold, not as a Virgin product, but under a different brand name.

Another type of unlawful trading is ‘bootlegging’. Like counterfeit records and pirated records, bootleg records are also big business. They comprise copies of an unlawful recording of a performance at a live concert. The recording is made at an auditorium or taken from a radio or television broadcast.

RANK FILM LTD v VIDEO INFORMATION CENTRE

[1982] AC 380 [UK]

It is, it is a glorious thing, to be a Pirate King, said WS Gilbert; but he was speaking of ship pirates. Today we speak of film pirates. It is not a glorious thing to be, but it is a good thing to be in for making money'

Film pirates plunder the best and most recent cinema films. They transpose them on to magnetic tape: and then sell video cassettes on the black market. This black market makes huge inroads into the legitimate business of the film companies. They have been put to great expense in producing the best films: they have the copyright which gives them the sole and exclusive right to reproduce them. Yet here are the pirates plundering it – stealing all the best films.

TELEVISION BROADCASTS LIMITED v MANDARIN VIDEO HOLDINGS

[1984] FSR 111 [Malaysia]

In this judgment, I speak of various things – of copyright and censorship, of Anton Piller orders and even pirates. I shall begin with pirates.

There are several kinds of modern-day buccaneers and they operate in all sorts of cunning and illicit ways. One kind is film pirates. Let Lord Denning take up the thread in his own inimitable style [the judgment proceeded to quote the preceding passages].

In this country, our buccaneers do things somewhat differently from the Americans. They do it for the money: 'It is a good thing to be in for making money. '

[The defendants] were engaged in offences contrary to section 15(1) of the Copyright Act 1969. The penalties are severe. But the criminal law can be slow and cumbersome at times for it to be effective.

The defendants have done great wrong to the plaintiffs. They have plundered the copyright in the plaintiffs' most recent television films. They have infringed the copyright in the films and have not paid a cent for them; they do not have to bear the huge cost of producing the films. Pirates proliferate the market with infringing copies at a fraction of the true price. For example, music pirates do not have to pay anything to the musicians and artistes. They have no production costs to bear, no studio time to pay for; they reap huge profits without

having to pay royalties. Piracy in whatever form is to be deprecated. Authors, publishers, song-writers, recording artistes and recording companies have all suffered from the plunder of pirates.

Pirates are men without scruples. These are not honest men that we speak of. These are thieves who have stolen from the plaintiffs the copyright in their best and most recent television films.

6. *Old case law:* Courts have expressed themselves on the issue since early times. The first quotation deals with trademarks and the second with the history of copyright.

PERRY v TRUEFIT

(1842) 49 ER 749 [UK]

I think that the principle on which both the courts of law and of equity proceed, in granting relief and protection in cases of this sort [an unregistered trademark case], is very well understood. A man is not to sell his own goods under the pretence that they are the goods of another man; he cannot be permitted to practice such a deception, nor to use the means which contribute to that end. He cannot therefore be allowed to use names, marks, letters or other indicia, by which he may induce purchasers to believe, that the goods which he is selling are the manufacture of another person. I have no doubt that another person has not the right to use that name or mark for the purposes of deception, and in order to attract to himself the course of trade, or that custom, which, without the improper act, would have flowed to the person who first used, or was alone in the habit of using the particular name or mark.

AUTODESK INC v YEE

(1996) 139 ALR 735 [Australia]

An element of penalty is an accepted feature of copyright legislation. The infringer has been regarded, at least since the eighteenth century, as a 'pirate', who ought to be treated accordingly. In *Millar v Taylor* (1769) 4 Burr 2303; 98 ER 201 reference was made to 'the whole jurisdiction exercised by the Court of Chancery since 1710, against pirates of copies'; and, in the same case it was said that the statute of Queen Anne of 1709, from which modern copyright law takes its origin, 'secures [the property of the copyright owner] by penalties'. The Copyright Act 1968 is entirely in keeping with traditional views of the matter.

7. *The term “counterfeit goods” is used for the sake of simplicity for both trademark and copyright infringements – and more:* Holders of intellectual property rights often own and manage a portfolio of rights that includes both industrial property (patents, designs and trademarks) and copyright and related rights. Most of the practical problems relating to the enforcement of industrial property rights and that of copyright and related rights are the same and for the sake of simplicity the term “counterfeit goods” is often used in a generic sense to include pirated copyright works.

A report by the Organisation for Economic Co-operation and Development prepared by Ms Hema Vithlani explains:³¹⁷

“Technically, the English term “counterfeiting” only refers to specific cases of trademark infringement. However, in practice, the term is allowed to encompass any making of a product which so closely imitates the appearance of the product of another as to mislead a consumer that it is the product of another. Hence, it may also include the unauthorised production and distribution of a product that is protected by other intellectual property rights, such as copyright and neighbouring rights. This is in line with the German term ‘*Produktpiraterie*’ and the French term ‘*contrefaçon*’, which both cover a broader range of intellectual property right infringement.

“In fact, different types of IPR infringements often overlap. Music piracy for example, mostly infringes copyright as well as trademark protection. Fake toys are often sold under a different name but infringe the design protection of the toy. Even where there is no trademark infringement, the evolving factual problems and subsequent legal issues often bear a close resemblance to cases of counterfeiting.”

8. *Other IP rights:* The TRIPS Agreement does not require criminal sanctions for patent infringement but provides optionally for them to be criminalized in the case of willful infringement on a commercial scale. Although countries such as Brazil, Japan,³¹⁸ and Thailand do criminalize patent infringement, this is not something found in most common-law jurisdictions.³¹⁹

317 *The Economic Impact of Counterfeiting* (1998): available at the OECD website.

318 1999 Patent Law s 196: “Any person who has infringed a patent right or an exclusive licence shall be liable to imprisonment with labour not exceeding five years or to a fine not exceeding 5 000 000 Yen.”

319 Irina D Manta *The Puzzle of Criminal Sanctions for Intellectual Property Infringement* 24 *Harvard Journal of Law & Technology* 269 (2011).

Industrial design registrations may also be protected by criminal sanctions but, once again, this is (except in those countries that criminalize patent infringement) not done as a rule. However, this limitation has a limited effect because there is often an overlap (in many countries) between copyright protection and the protection of industrial designs: most designs are automatically protected by copyright. Furthermore, some designs may have trademark significance and can be protected as such.

9. *Related activities:* Activities related to counterfeiting, but which are not necessarily so treated by enforcement laws, are parallel importation and factory over-runs. Reference is again made to the paper of the OECD prepared by Hema Vithlani. She stated the following:

“‘Parallel trading’ refers to situations where products are legitimately bought in one territory and diverted for sale to another territory without the consent of the right holder in the receiving territory. It is facilitated by two principles that limit the rights of an IPR owner: *i)* the principle of territoriality, *i.e.* the IPR protection is valid only for specific countries or regions; and *ii)* the principle of exhaustion, *i.e.* the right owner has very limited rights to prevent further distribution of a product that is put on the market with his consent.

A related problem for trademark owners is the unauthorised production by legitimate suppliers. In some sectors, such as toys and spare parts, it has become the practice for suppliers to produce ‘over-runs’ – extra quantities of products which they do not account for – and sell them on the black market. The trademark owner again considers the goods to be counterfeits but finds it difficult to take action. Courts and enforcement agencies treat over-runs as a breach of contract rather than as a trademark infringement.”

B. THE SOURCE OF THE OBLIGATION TO CRIMINALIZE

10. *The source of the obligation to criminalize:* The international obligation to provide for criminal sanctions derives from the TRIPS Agreement. More particularly, Article 61 states as follows (bullets added):

- Members shall provide for criminal procedures and penalties to be applied at least in cases of willful trademark counterfeiting or copyright piracy on a commercial scale.

- Remedies available shall include imprisonment and/or monetary fines sufficient to provide a deterrent, consistently with the level of penalties applied for crimes of a corresponding gravity.
- In appropriate cases, remedies available shall also include the seizure, forfeiture and destruction of the infringing goods and of any materials and implements the predominant use of which has been in the commission of the offence.
- Members may provide for criminal procedures and penalties to be applied in other cases of infringement of intellectual property rights, in particular where they are committed willfully and on a commercial scale.

11. *The criminalization of counterfeiting and piracy did not originate with TRIPS:* There are historical antecedents for the criminalization of counterfeiting. Trademark counterfeiting has been criminalized since, at least, the end of the 19th century. For example, the US Act of August 14, 1876 already punished counterfeiting of trademark goods and dealing in counterfeit trademark goods.³²⁰ Most, if not all, countries that fell under the British Crown had laws with a similar effect. These were statutes that dealt with merchandise marks and false trade description. (These statutes are still common and in their present form are much the same as they were originally.) Copyright infringement, likewise, was criminalized since the beginning of the 20th century in all British dependencies.³²¹ But it goes back further: the Statute of Anne on copyright of 1709 entitled an informant to recover a penny a sheet for infringing copies, half of which went to the Crown.

Although the classic conventions on IPR, namely that of the Paris Convention (on industrial property) and of the Berne Convention (on copyright), did not and do not provide in express terms for criminal sanctions in the event of counterfeiting or piracy, the type of provision just mentioned can be traced to those conventions.³²²

12. *TRIPS did not introduce any revolutionary principles: Counterfeiting may be regarded as a species of fraud – not necessarily on the consumer but on the state or the rights holder.*³²³

320 For the history of criminal enforcement in the US: Jana Nicole Checa Chong *Sentencing luxury: The valuation debate in sentencing traffickers of counterfeit luxury goods* [77] Fordham LR 1147.

321 By virtue of s 11 of the 1911 British Act which provided (*inter alia*) in s 11 that any person who knowingly (i) makes for sale or for hire; (ii) trades in; (iii) distributes; (iv) by way of trade exhibits; or (v) imports for sale or hire infringing works, is guilty of an offence. The Patents, Designs, Trade Marks and Copyright Act 9 of 1916 (South Africa) adopted these provisions in an annexure. They are still in, for example, the Trade Description Act 1972 (Malaysia) s 8.

322 Michael R Ryan *Gray markets, intellectual property rights, and trade agreements in the international marketplace* discusses the enforcement provisions of IP conventions in the context of gray goods: www.cherry.gatech.edu/t2s2006/papers/ryan-3003-2-T.pdf.

323 *R v Priestly* [1996] 2 Cr App Rep (S) 144.

“Counterfeiting is a form of deceit. A counterfeit product is something that has been forged, copied or illegally imitated for the purpose of extracting money from credulous or consenting clients to the detriment of the legal manufacturer.”³²⁴

And piracy is often referred to as a species of theft (albeit of intangible property). But this does not mean it is theft.³²⁵ The use of hyperbole is deprecated by some, and may even be counterproductive.³²⁶

NETWORK TEN PTY LIMITED v TCN CHANNEL NINE PTY LIMITED

[2004] HCA 14 [Australia]

Professor Waddams,³²⁷ speaking of the use of terms such as ‘piracy’, ‘robbery’ and ‘theft’ to stigmatize the conduct of alleged infringers of intellectual property rights, describes ‘the choice of rhetoric’ as ‘significant, showing the persuasive power of proprietary concepts’. He also remarks:

‘Against the merits of enlarging the property rights of one person or class of persons must always be set the loss of freedom of action that such enlargement inevitably causes to others.’

C. THE REASONS FOR CRIMINAL SANCTIONS

13. Reasons for criminal sanctions for IPR infringement: Intellectual property rights are private rights and it is legitimate to ask whether these rights should be enforced by means of criminal sanctions and why civil remedies do not suffice.³²⁸ The short answer is that criminal law, in general, protects private rights against infringement if there is a public policy element involved. A typical example is theft.

“Civil remedies are not effective because counterfeiters are criminals. They do not respect the law, and they strategically and tactically carry out their criminal activities in ways explicitly designed to avoid the justice system, both civil and criminal.”³²⁹

324 Donal P. O’Mathuna and Adam McAuley *Counterfeit Drugs: Towards and Irish Response to a Global Crisis* (2005): buysafedrugs.info/uploadedfiles/IrishPatientsAssoc_counterfeit.pdf.

Another view is that it is akin to the theft of goodwill: *R v Bhad* [1999] 5 Cr App Rep (S) 139.

325 *Rank Film Ltd v Video Information Centre* [1982] AC 380; *Dowling v US* 473 US 207 (1985).

326 Steven N Baker & Matthew Lee Fesak *Who cares about the counterfeiters?* 83 St John’s LR 735.

327 *Dimensions of Private Law: Categories and concepts in Anglo-American legal reasoning* (2003).

328 Andreas Rahmatian Trade mark infringement as a criminal offence 67 (4) *Modern Law Review* 670.

329 Canadian Anti-Counterfeiting Network *Report on Counterfeiting and Piracy in Canada: A Road Map for Change* (2007): http://www.cacn.ca/PDF/CACN%20Releases/Roadmap_for_Change.pdf.

Honest traders may infringe IP rights but they do not counterfeit.

The US Department of Justice justifies criminal sanctions in order “to punish and deter the most egregious violators: repeat and large-scale offenders, organized crime groups, and those whose criminal conduct threatens public health and safety.”³³⁰

14. *Public interest issues* :Public interests wider than the mere protection of private rights are at stake in the case of counterfeiting. These include the protection of:

- public health and safety,
- tax and customs income,
- local and regional industries,
- foreign investment and investor confidence,
- international trade relations, and
- the prevention of corruption and organized crime.

15. *Alternative charges*:The acts that give rise to charges of counterfeiting or piracy may also give rise to other alternative or additional charges, some of which might be easier to establish. In this regard the following may be considered:

- fraud,
- customs and excise contraventions,
- tax evasion,
- racketeering and money laundering,
- food and drug legislation,
- labor related legislation, and
- trading offences.

16. *Public health issues*: The participants at the WHO International Conference on Combating Counterfeit Drugs: Building Effective International Collaboration, declared that:³³¹

- Counterfeiting medicines, including the entire range of activities from manufacturing to providing them to patients, is a vile and serious criminal offence that puts human lives at risk and undermines the credibility of health systems.
- Because of its direct impact on health, counterfeiting medicines should be combated and punished accordingly.

330 *Intellectual Property—An Introduction* published by the Computer Crime & Intellectual Property Section: justice.gov/criminal/cybercrime/ipmanual/01ipma.html.

331 Rome, February 18, 2006. who.int/medicines/services/counterfeit/RomeDeclaration.pdf.

The United Nations Interregional Crime and Justice Research Institute study entitled “Counterfeiting: a global spread, a global threat” highlighted the scope and dangers of counterfeiting as at 2006.³³² It gave these examples:

- The use of counterfeit baby milk-powder formula containing no nutritional value caused the death of at least 13 babies in China in 2004.
- In 2005, a counterfeit alcoholic beverage containing lethal levels of methyl alcohol caused the death of 23 people in Turkey.
- The use of diethylene glycol pharmaceuticals killed more than 100 people in Panama in 2006.
- According to the World Health Organization, more than 50 per cent of medicines purchased online from Internet sites concealing their URL addresses are counterfeit and that between 7 and 10 per cent of all pharmaceutical products in the world are possible counterfeits, reaching a total of 30-40 per cent in some African countries and of 20 per cent in the former Soviet republics.
- In the European Union the seizure of counterfeit pharmaceuticals increased by 383 per cent from 2005-2006.

17. Organized crime, and tax and customs losses: The major import of counterfeit goods is that of cigarettes, tobacco and alcoholic beverages according to the European experience. These products usually carry hefty customs and excise duties and the ability to sell them at their usual prices without having to account to the tax authorities is a major incentive for counterfeiting. Such operations can only be conducted by organized crime syndicates. As Prof. Michael Blakeney pointed out:³³³

“The most serious consequences of the trade in counterfeit and pirate products are the stimulation of organized criminal activity and the consequential effects upon public. Profits from this trade are appropriated by organized crime, which uses them as a means of recycling and laundering the proceeds of other unlawful activities. Counterfeiting and piracy have become almost industrial-scale activities offering criminals the prospect of large economic profit without excessive risk. With the advent of e-Commerce the rapidity of illegal operations and the difficulty of tracking the operations further reduce the risks for the criminal. Counterfeiting and piracy thus appear to be a factor in promoting crime, including terrorism.

332 <http://www.unicri.it/>.

333 *Policy responses to the involvement of organized crime in intellectual property offences* available at wipo.int.

Organized criminals often combine counterfeiting and piracy with smuggling. The trade routes which were developed for the smuggling of drugs and arms have provided an existing infrastructure for the trade in counterfeit and pirate products.”

An older WIPO report, relying on responses from Member States, said much the same:

“The phenomenon of counterfeiting and piracy of intellectual property rights is a serious international problem, with confirmed links to other forms of organized crime. Counterfeiting and piracy have been shown to cause multi-billion dollar losses annually to right holders and industry, and have had, in some instances, devastating consequences on public health and safety. Member States also suffer considerable losses in the form of lost tax revenues, lost employment opportunities, and lost investments.

One of the biggest problems Member States claimed is that consumers do not always realize the real dangers linked with supporting illegal trade in counterfeit goods or pirated copyright works. In supporting this illegal trade, they are often directly supporting organized crime. It often escapes the public that not only will legal employment opportunities be reduced, but that governments will not be able to realize certain taxes, a consequence effecting other vital areas such as health and welfare.”³³⁴

“A further direct loss for the government of countries that become havens for counterfeiters, are *tax losses*, since the counterfeits are normally sold through clandestine channels and counterfeiters are not generally keen to pay tax on their ill-gotten gains. Fiscal losses are increasingly shown to justify action by enforcement officials.”³³⁵

18. *The advantages of trading in counterfeit goods:* But there is also an advantage to trade in counterfeit products if compared to other criminal activities.³³⁶

“Counterfeiting and piracy carried out on a commercial scale are even said to have become ‘more attractive nowadays than drug trafficking’, since high potential profits can be obtained without the risk of major legal penalties.

334 WIPO document WIPO/CME/3 July 26, 2002.

335 OECD report.

336 Michael Blakeney *op cit*.

The trade routes which were developed for the smuggling of drugs and arms have provided an existing infrastructure for the trade in counterfeit and pirate products. Indeed, the profitability of infringing products is now beginning to exceed that of drugs and arms, on a profit/weight basis, and often with lower penalties should the perpetrator be identified.”

19. *Commercial and public interests:*

SLINEY v LONDON BOROUGH OF HAVERING

[2002] EWCA Crim 2558 [UK]

Implicit in the provisions of sections such as s 92 [of the Trademarks Act] itself is the objective not only of protecting the ownership rights relating to registered trademarks but also of enhancing trade and promoting a legitimate economy and of providing consumer protection. Trademarks have a value, often a very great value. People commonly buy products bearing a particular trademark just because the products bear that trademark: as representing or connoting some or all of the characteristics of reliability, quality and fashion. It is precisely for that reason that there are those who seek to counterfeit goods bearing such marks: counterfeiting being an ever-increasing problem.

Moreover there are also important considerations of public safety involved: counterfeit goods (in the form of toys or packaged foodstuffs or motor vehicle parts for example) have in numerous ways over the years proved to be highly dangerous.

A degree of protection, both in the mercantile and public interest, in respect of trademarks, going beyond the civil remedies available, is plainly desirable.

20. *The function of criminalizing counterfeiting:*³³⁷ The criminalization of trademark counterfeiting serves at least four important functions.

- Protecting the intellectual property assets of a trademark holder from theft or dilution. Trademark holders cannot protect their intellectual property through the traditional security means – such as guards and audits – used to protect their other assets. Also, by selling inferior products, the counterfeiter devalues a

337 This paragraph represents a quotation from *Prosecuting Intellectual Property Crimes*, a manual of the US Department of Justice Executive Office for US attorneys. The work is available on the Internet: www.usdoj.gov/criminal/cybercrime/ipmanual.

trademark holder's good name even while profiting from it. [See the *Loendersloot* judgment quoted below.]

- Protecting consumers from fraud. Consumers are entitled to rely on trademarks when making their purchasing decisions. Yet counterfeit goods can be of much lower quality, and can even present serious health or safety risks to consumers, as in the cases of counterfeit food products, prescription drugs, or automotive parts.
- Protecting safety in society for non-purchasing users. Sales of counterfeit products often victimize not only the trademark holder and purchaser, but also non-purchasing users. For example, airlines may purchase counterfeit airplane parts of which passengers may be victims; hospitals may purchase counterfeit heart pumps of which patients may be victims; and parents may purchase counterfeit infant formula that harms their children.
- Enforcing market rules. Just as counterfeiting money and forgery are crimes that undermine fundamental market rules, counterfeiting of trademarks weakens modern commercial systems.

21. *Protecting the guarantee function of trademarks:*

LOENDERSLOOT v GEORGE BALLANTINE & SON LTD

ECJ, 11 November 1997, C-349/95, ECR 1997, I-6227

With respect to trademark rights, [this] court has held that they constitute an essential element in the system of undistorted competition. In such a system, undertakings must be able to attract and retain customers by the quality of their products or services, which is made possible only by distinctive signs allowing them to be identified. For the trademark to be able to fulfill that function, it must constitute a guarantee that all products which bear it have been manufactured under the control of a single undertaking to which responsibility for their quality may be attributed. Consequently, the specific subject-matter of a trademark is in particular to guarantee to the owner that he has the exclusive right to use that mark for the purpose of putting a product on the market for the first time and thus to protect him against competitors wishing to take unfair advantage of the status and reputation of the trademark by selling products illegally bearing it.

22. *The danger of over-criminalization :* Since counterfeiting is primarily a civil issue the dangers of over-criminalization are obvious. This is especially the position in the developing world where enforcement of IP rights is primarily a criminal issue and not a civil one. For this reason one finds much

more criminal law activity in the developing world whereas the civil route is preferred in the developed world.

Judge Jumpol Pinyosinway of the Central Intellectual Property and International Trade Court of Thailand argued that:³³⁸

- IPR criminalization, with severe penalties, has grown rapidly in developing countries, which coincides with the broadening of IPRs under pressure of developed countries.
- All expected and unexpected infringements are now criminalized even if the particular act is not perceived to be morally reprehensible within a particular community or is criminalized to the same extent in developed countries.
- The new crimes ignore the differences between the different types of infringers.
- IPR enforcement, in principle, should be civil, which is the preferred method of protecting IPRs in developed countries.

Rights owners argue differently. They accept that the civil route is the appropriate one, but say that civil enforcement is not necessarily effective in all countries. Absent proper civil recourse means they have to rely on criminal measures. This may be due to problems with the judicial system, questions of costs, or the inability of defendants to pay damages.

Some countries, significantly the USA, have a civil enforcement system with inbuilt penal provisions. Courts may award statutory damages if the infringement was willful. Punitive damages are also available in some other jurisdictions against a deliberate infringer who has behaved in a particularly appalling manner.

23. *The requirement of due process:* Although counterfeiting is a serious crime it does not mean that the requirements of due process should not be kept in mind.

COMMISSIONER OF CUSTOMS AND EXCISE v GOLDEN SCIENCE TECHNOLOGY LIMITED

Hong Kong Appeal Court

Each case must, in our view, be considered on its own facts. There is no doubt as to the seriousness of software piracy. The matter is not simply a matter of the private interests of the copyright owners; it is a matter of public interest to Hong Kong generally. The effectiveness of enforcement of copyright is now an international issue. It has caused,

³³⁸Criminal Enforcement of IPR: The Problem of 'Over-Criminalization' which appeared in the Sixth Anniversary Special Issue 2003 of the *Intellectual Property and International Forum*, Thailand.

amongst other things, the enactment of the provisions in the Copyright Ordinance to which reference is made. The remedies available for infringement of copyright can be extensive. If infringement has been proved, the respondents in these proceedings could be open not only to forfeiture of its equipment but to massive penalties.

No doubt, the profits open to those who infringe software copyright are substantial and no doubt heavy sanctions are important to preserve and enforce the law. The due process of law however involves an even handed approach and proper proof of guilt of those whom it is sought to punish.

D. THE FINANCIAL IMPACT OF COUNTERFEITING

24. Introduction: The losses due to counterfeiting cannot be determined with any degree of accuracy. Many studies have been done but nearly all can be faulted in one way or another³³⁹. It is not possible to determine the extent of what is primarily a clandestine business operation active across borders of many countries. In addition, rights holders may have an interest in overstating the extent of the problem.³⁴⁰ Counterfeiters do not register their operations and they do not pay tax or customs or excise duties. And, if they do, they under-declare the value of the goods. Then there is the credit side of counterfeiting that has to be accounted for: dealing in counterfeit goods does provide a livelihood for many who have no other source of income. Prof. Michael Blakeney dealt with the issue in some detail in a WIPO study and said:³⁴¹

“There is inevitably a good deal of imprecision in the metrics of counterfeiting and piracy. One reason for this is that because it is a clandestine and criminal activity the true extent of counterfeiting and piracy is impossible to calculate with accuracy.

The statistics of industry associations, since they are intended to highlight the extent of the problem of the trade in infringing products, are inevitably biased upwards.

339 For critical assessments of these kinds of statistics see Carsten Fink *The Economic Effects of Counterfeiting and Piracy: A Literature Review*, in the sixth session of the ACE (2010) (http://www.wipo.int/edocs/mdocs/enforcement/en/wipo_ace_6/wipo_ace_6_7.pdf); Loren Yager *Observations on Efforts to Quantify the Economic Effects of Counterfeit and Pirated Goods*, in the sixth session of the ACE (2010) http://www.wipo.int/edocs/mdocs/enforcement/en/wipo_ace_6/wipo_ace_6_4.pdf; Charles Clift, *A Review of Statistical Information on Counterfeiting and Piracy*, in the seventh session of the ACE (2011) (http://www.wipo.int/edocs/mdocs/enforcement/en/wipo_ace_7/wipo_ace_7_5.pdf).

340 On the other hand, over 95 per cent of custom interventions in the EU resulted from applications of rights holders, which have risen sharply in recent years (981 in 2000 to over 18,000 in 2010). Around 2.5 per cent of detained goods turn out to be legitimate.

341 *Policy responses to the involvement of organized crime in intellectual property offenses* available at wipo.int.

Similarly, the statistics of enforcement authorities, such as police and customs are also likely to be exaggerated with a view to securing favourable future budget allocations if the problems with which they are dealing are magnified.”

“The losses to producers of genuine items cannot be quantified by subtracting the number of items sold from the total number of units that could be absorbed by the market, *i.e.* the total market size. The market for genuine products and that for counterfeits should be treated as two separate markets, where the tools to measure the former will not necessarily apply to the latter.”³⁴²

In spite of this, it cannot be doubted that the losses to industry world-wide run into billions of dollars every year. These costs impact on victim countries in a number of different ways.

25. *Estimates of the scope of counterfeiting: A United Nations Interregional Crime and Justice Research Institute study gave these estimates for 2006.*³⁴³ Since 2006 the figures have merely escalated and an update adds little to the point made.

- According to the European Commission, counterfeiting is estimated as totaling between 5 and 7 per cent of the legal market.
- The Organization for Economic Cooperation and Development (OECD) calculated that up to US \$200 billion of international trade in 2005 could have been in counterfeit or pirated products.
- Data from the World Customs Organization and the European Commission showed an increase of 88 per cent in the seizures of counterfeit goods in the European Union between 2000 and 2006.
- The sectors most affected in the EU were the data-processing sector (35 per cent of all commerce), the audio-visual sector (25 per cent), the toy sector (12 per cent), the perfume sector (10 per cent), the pharmaceutical sector (6 per cent) and the clock (watches) sector (5 per cent).
- Italian customs, in 2006, intercepted 121,229 items counterfeit spare parts for the automotive sector, the Philippines (49,328) Lithuania (30,517) and Germany (27,252). Italian customs also registered the highest number of counterfeit toys seized in the years 2005 and 2006 (10,051,781 items intercepted in 2006), followed by Dutch (1,243,777) and German (468,062) customs.

342 The OECD report.

343 *Counterfeiting: a global spread, a global threat: <http://www.unicri.it/>*. For more up-to-date information see OECD (2008) *The Economic Impact of Counterfeiting and Piracy: www.oecd.org/sti/counterfeitingand* later updates.

- The losses in terms of reduced tax revenues were estimated to be *circa* US \$3 billion per year for the Chinese Government and US \$2.4 billion for the UK.

26. *Direct loss in sales:*³⁴⁴

“First of all, industries which find themselves in direct competition with counterfeiters suffer a *direct loss in sales*. Indeed, some markets are even dominated by counterfeiters, creating barriers of entry for the producers of the genuine product. Some would argue that the buyers of the fakes would not have bought the genuine item but that is a very narrow argument and can only apply to a small segment of luxury goods. Many counterfeit products today are of higher quality and compete directly with the genuine items.”

The third sentence requires qualification or clarification. It is known that many fake luxury goods are bought as fakes by persons who would not have bought the original because of the cost of the original. It is difficult in those circumstances to say that the rights holder has suffered a loss of sales. Whether there is a loss of goodwill is also debatable.

27. *Loss of goodwill:*

“In addition, consumers who are deceived into believing that they bought a genuine article when it was in fact a fake, blame the manufacturer of the genuine product when it fails, creating a *loss of goodwill*. Even cheaper and obvious copies that are bought in good faith represent a serious threat to the company that wants its brands associated with quality and exclusivity.”

This statement also requires qualification because it does not apply when persons knowingly purchase counterfeit goods, as they often do in relation to luxury goods.

28. *Enforcement costs:*

“Thirdly, beside direct losses of sales and goodwill, one should not forget the expenditure involved in *protecting and enforcing* intellectual property rights. The right owner becomes involved in costly investigations and litigation when combating counterfeiters and may also have to spend further sums on product protection.”

344 What follows has been taken from the report by the OECD prepared by Hema Vithlani mentioned earlier.

29. Loss of foreign investment:

“First, foreign producers of reputable products become reluctant to manufacture their products in countries where counterfeiting is rife as they cannot rely on the enforcement of their intellectual property rights. Hence, such countries not only *lose direct foreign investment* but also *miss out on foreign know-how*.

Second, if many products from such countries, including genuine ones, gain a reputation of being of poor quality, this will cause export losses which in turn implies both *job losses* and *loss of foreign exchange*. It could be argued that the counterfeiting industry creates jobs but these jobs are often poorly paid, often involve substandard working conditions and sometimes use child labour.

Third, the foundation for new business development in a country is the existence of a legal system to protect the rights of the entrepreneur and to promote fair competition. The prevalence of counterfeiters in a market *discourages inventiveness* in that country since it deters honest producers from investing resources in new products and market development.”

30. Costs to countries where counterfeits are sold:

“Countries promoting tougher enforcement of intellectual property rights in the world have a strong case for doing so. The economic costs of counterfeiting for such “victim” countries include *job losses, missed sales opportunities and lost tax revenues*. In the long run counterfeiting *discourages investment in product development* since a company will not get all the benefit from its investment.”

31. Social costs:

“Ultimately, it is the consumer who pays the cost of unfair competition. Although many consumers believe they are getting a bargain when they buy counterfeits, the actual value of the product is normally much lower.”

E. REASONS FOR THE PREVALENCE OF COUNTERFEITING³⁴⁵

32. *To copy is inherent the human nature:* The Greek philosopher Aristotle (350 BCE) held the view that art is imitation, and that imitation is good because it is natural to humans from childhood and because children and we all learn from imitation. He said:³⁴⁶

“First, the instinct of imitation is implanted in man from childhood, one difference between him and other animals being that he is the most imitative of living creatures, and through imitation learns his earliest lessons; and no less universal is the pleasure felt in things imitated. We have evidence of this in the facts of experience. Imitation, then, is one instinct of our nature.”

33. *Correlation between culture and the level of copying:*³⁴⁷ The literature identifies three issues in this respect:

- *Attitudes to intellectual property* vary between cultures because cultures differ in terms of the entity to which they assign a right of ownership. Thus in much of the West there is an acceptance of individualism which is not found in some other parts of the world, for example, in collectivist cultures. This is encapsulated by the view of Lao Tzu (500 BCE) namely that the hidden virtues are to produce without appropriation and to create without controlling.
- *Attitudes to 'big business'*: Consumers who purchase counterfeit material knowingly often hold a negative attitude to big business.
- *Attitudes to the supply and purchase of counterfeit software* are very mixed with many people being prepared to knowingly purchase such items. There is also a body of opinion that seriously questions the concept of intellectual property being applied to software.³⁴⁸

345 For a useful study on consumer attitudes see Hardy (BASCAP Coordinator, International Chamber of Commerce (ICC), Paris) *Research Report on Consumer Attitudes and Perceptions on Counterfeiting and Piracy*: http://www.wipo.int/meetings/en/details.jsp?meeting_id=20199. See also, on the whole issue of the prevalence of counterfeiting: Sisule Musungu *The Contribution of, and Costs to, Right Holders in Enforcement, Taking Into Account Recommendation 45 of the WIPO Development Agenda* http://www.wipo.int/edocs/mdocs/enforcement/en/wipo_ace_5/wipo_ace_5_10.pdf, and Joe Karaganis *Media Piracy in Emerging Economies: Price, Market Structure and Consumer Behavior* http://www.wipo.int/edocs/mdocs/enforcement/en/wipo_ace_6/wipo_ace_6_5.pdf.

346 Translation by S H Butcher.

347 J. Freitas Santos and J. Cadima Ribeiro *An investigation of the relationship between counterfeiting and culture: evidence from the European Union*, EURAM 2006 Conference: econpapers.repec.org/paper/nipnipewp/4_2F2006.htm. References have been omitted from the quotation. But see Peter K Yu *Four common misconceptions about copyright piracy* 26 *Loyola Los Angeles International and Comparative Law Review* 2003: papers.ssrn.com/sol3/papers.

348 Rujirutana Mandhachitara and Tasman Smith *Thailand's Counterfeit Dilemma*, ANZMAC 2000 Visionary Marketing for the 21st Century: Facing the Challenge: smib.vuw.ac.nz:8081/www/ANZMAC2000/CDsite/papers/m/Mandhac1.PDF.

34. Socio-economic factors: A study in India concluded that:³⁴⁹

“though social factors like illiteracy, unemployment etc. influence piracy, the phenomenon occurs more because of economic reasons than anything else. For pirates it is an easy way of making quick bucks. For the end users it is a gainful arrangement for buying/using a variety of info-entertainment products which otherwise remain unaffordable at least to a vast majority. Basically, this ‘win-win’ situation for pirates and end users keeps the piracy alive and active in the society. Other socio-economic variables like poverty and high prices etc. only add to the degree of the problem.”

35. Trends: The EC noted the following qualitative changes in the nature of counterfeit goods imported into the EC:

- A high increase in fake goods which are dangerous to health and safety.
- Most products seized are now household items rather than luxury goods.
- Growing numbers of sophisticated hi-tech products.
- Production is on an industrialized scale.
- High quality of fakes often makes identification impossible without technical expertise.

“The EC surmised that among the reasons for the large increase in trade in fakes were

- the high profits and comparatively low risks involved, particularly when it comes to penalties in some countries;
- from a general global growth in industrialized capacity to produce high quality items; and
- by the growing interest of organized crime in taking a share of these high profits.

Because of the latter, the EC has identified serious public health and security risks particularly involving seizures of dangerous goods include counterfeit pharmaceuticals, foodstuffs, washing powder, and unsafe toys.”³⁵⁰

349 copyright.gov.in/mainpract9.asp.

350 Michael Blakeney *op cit*.

36. *Advances in technology:*

“New technology has not only benefited manufacturers of genuine products, but also counterfeiters. New techniques have enabled counterfeiting of what were normally considered as “high-tech” products, too complicated to fake.”

- *Increased international trade:* “International trade, including trade in counterfeit products, has increased dramatically over the last few decades. Virtually all regions are both production and consumption areas for counterfeit products.”
- *Removal of borders:* “In view of the world-wide growth of regional economic integration, the effects of any expansion in border measures to combat counterfeiting have been offset by a more general trend in favour of dismantling border controls to ease the flow of international trade.”
- *Emerging markets:* “A number of economies that were previously controlled are now being transformed into free market economies. Unfortunately, the speed of transformation has been somewhat too fast for the enforcement agencies.”
- *Emerging products:* “The share of semi-manufactured and manufactured products has increased world trade at the expense of trade in raw materials. Technological development is enabling counterfeiters to produce fakes relatively cheaply and easily.”

F. THE SUCCESS OF CRIMINAL SANCTIONS

37. *Variable success:* The available statistics indicate that criminal sanctions have not always or everywhere had a real impact on IP crimes. As mentioned, criminal enforcement is now the main tool of enforcement in developing countries. For instance, in 2002 criminal IP cases were 93 per cent of the total of all IP cases in Thailand: 3 896 criminal and 292 civil. In Malaysia, for 2006, there were 4 268 counterfeiting charges and 1 472 of piracy.³⁵¹ There is, however, a huge difference in completion and conviction rates between countries.

38. *Systemic problem:* Most countries have systemic – indeed, sometimes, endemic – problems in relation to criminal enforcement. The problem concerning the enforcement of IP rights is not exceptional. These systemic problems flow from the administration of justice in general and are not necessarily peculiar to IP crimes.

351 Karen Abraham Zero tolerance for infringement [2007] *Managing Intellectual Property* (2 ed).

- *Ambivalent attitude towards IP:* The governments of some countries express, depending on the forum or the ministry involved, ambivalent or conflicting views about the value and protection of IPRs. This attitude (or lack of it) filters down to those responsible for enforcement, including the judiciary.
- *Qualification of the judiciary:* The judiciary is not necessarily qualified to deal with technical matters. In many common-law countries the judiciary is averse to any training (particularly post-appointment), fearing that it may affect its independence. There is also a difference of opinion about the judiciary's general ability to deal with such matters. However, issues concerning counterfeiting or piracy are usually within the competence of any judicial officer.
- *Ability of the investigating and prosecuting authorities:* These authorities may not have the necessary expertise or resources to investigate and prosecute technical issues.
- *Rules of evidence:* The common-law system is known for its over-reliance on oral evidence and its reluctance to permit written evidence, even if the accused has no grounds for doubting its veracity.
- *Over-burdened courts:* In many countries criminal courts are over-burdened and suffer from serious backlogs. The period between arrest and trial may be unacceptably long. Witnesses may disappear, complainants may lose interest, exhibits may disappear and the prosecution may regard the matter as stale.
- *Court management:* Because of the adversary legal system in common-law countries, their judiciaries tend to leave the management of litigation in the hands of the parties. This may lead to unnecessary postponements and lengthy delays in concluding litigation.³⁵²
- *General level of criminality:* Legislatures, the prosecution and courts have to prioritize their work. IP crimes do not, as a rule, rate high especially in high-crime communities.
- *Poor discretionary decisions:* The decision to prosecute or not to prosecute is occasionally is sometimes based on insufficient information.
- *Dealing with exhibits:* Exhibits have to be tagged, stored and eventually produced in court. Ultimately, they have to be turned over to the rights owner or be destroyed. Some countries experience problems in this regard also in view of the time limits imposed by TRIPS.

352 Thailand has this rule: "The court shall proceed with the hearing without adjournment until the hearing is over, save in case of unavoidable necessity."

- *Inappropriate sentences:* There is often a difference of opinion between members of the judiciary and the Legislature on questions relating to sentencing. The judiciary wants to exercise free discretion while legislatures tend to be prescriptive and wish to bind the judiciaries' sentencing discretion.

G. PROCEEDS OF CRIME LEGISLATION

39. *United Nations International Convention against Transnational Organized Crime:* Article 12.1 of the Convention provides:

States Parties shall adopt, to the greatest extent possible within their domestic legal systems, such measures as may be necessary to enable confiscation of:

- (a) Proceeds of crime derived from offences covered by this Convention or property the value of which corresponds to that of such proceeds;
- (b) Property, equipment or other instrumentalities used in or destined for use in offences covered by this Convention.

40. *Objects:*

“Depriving criminals of their assets can have a greater punitive effect on many of them than going to prison. Confiscating the illicit profits is often the most effective form of punishment and deterrence for those who organize criminal undertakings. This is certainly the case with counterfeiting and piracy, where the rewards from criminality considerably outweigh the risks, given the fairly low fines which are imposed.”

The principal objects of the Proceeds of Crimes Acts are, accordingly, to:³⁵³

- deter crime by reducing its profitability;
- prevent the reinvestment of proceeds, instruments, benefits in further criminal activity;
- deprive persons of the proceeds of offences, the instruments of offences, and benefits derived from offences;
- assist detection and investigation by enabling law enforcement authorities effectively to trace criminal proceeds;
- defray the expense of criminal enforcement;
- compensate society for the harm caused by organized crime; and

to keep faith with the vast majority of people who do not commit crimes and who do meet their obligations to the community by paying taxes and acting within the law.

H. THE DECISION TO PROSECUTE

41. *Prosecutorial discretion:* The decision to prosecute may depend on prosecutorial discretion within any particular jurisdiction. In the USA, for instance, counterfeiting is a federal crime and federal prosecutors have a wide discretion whether or not to prosecute. Nevertheless, their guidelines are useful. What follows has been taken from a paper, which is available on the internet, prepared by David Goldstone.³⁵⁴

“Prosecutors may consider any number of factors to determine the seriousness of an IP crime, including:

- Whether the counterfeit goods or services present potential health or safety issues;
- The scope of the infringing or counterfeiting activities, as well as the volume of infringing items manufactured or distributed;
- The scale of the infringing or counterfeiting activities;
- The number of participants and the involvement of any organized criminal group;
- The scale of the victim’s loss or potential loss, including the value of the infringed item, the size of the market for the infringed IP that is being undermined, and the impact of the infringement on that market;
- Whether the victim or victims took reasonable measures (if any) to protect against the crime; and
- Whether the purchasers of the infringing items were victims of a fraudulent scheme, or whether there is a reasonable likelihood of consumer mistake as a result of the subject’s actions.”

42. *Additional considerations:* Apart from the question of seriousness, he suggests that prosecutors consider the following issues:

- Enforcement priorities;
- The deterrent effect of prosecution (an issue discussed later under Sentencing);
- The individual’s culpability in connection with the offense;
- The individual’s history with respect to criminal activity;

³⁵⁴ *Deciding Whether to Prosecute an Intellectual Property Case*, available at: http://www.cybercrime.gov/usamarch2001_1.htm

- The individual's willingness to cooperate in the investigation or prosecution of others ;
- The probable sentence or other consequences if the person is convicted ;
- Whether the person is subject to prosecution in another jurisdiction, and
- The adequacy of a non-criminal alternative in an IP case.

I. LIABILITY OF ACCESSORIES

43. *Liability of accessories:* The liability of accessories can be civil or criminal and the principles are, depending on the question of *mens rea* and particular criminal legal precepts, more or less the same. The matter is discussed here as a matter of convenience.

The liability of an accessory to counterfeiting usually depends on the question whether the alleged accessory authorized the infringing acts.³⁵⁵In determining whether a person is a joint tortfeasor regard is had to:

- the extent of his power to prevent the doing of the act;
- the nature of any relationship between him and the person who did the act; and
- whether he took any other reasonable steps to prevent or avoid the doing of the act.

44. *Inducing or encouraging direct infringement:*

METRO-GOLDWYN-MAYER STUDIOS INC v GROKSTER, LTD

380 F.3d 1154 [USA]

One infringes contributorily by intentionally inducing or encouraging direct infringement and [one] infringes vicariously by profiting from direct infringement while declining to exercise a right to stop or limit it. Although "[t]he Copyright Act does not expressly render anyone liable for infringement committed by another," these doctrines of secondary liability emerged from common law principles and are well established in the law.

The classic case of direct evidence of unlawful purpose occurs when one induces commission of infringement by another, or "entic[es] or persuad[es] another" to infringe as by advertising. Thus at common

355 *Zero Tolerance v Venus Adult Shops* [2007] FMCA 155. Daniel Seng "Comparative analysis of the national approaches to the liability of internet intermediaries": www.wipo.int/.../en/doc/liability_of_internet_intermediaries_06092011.pdf.

law a copyright or patent defendant who “not only expected but invoked [infringing use] by advertisement” was liable for infringement on principles recognized in every part of the law.

- 45.** *Procuring a breach of copyright:* Selling an apparatus that may be used for lawful and unlawful copying does not amount to procuring.

CBS SONGS LTD v AMSTRAD CONSUMER ELECTRONICS PLC

[1988] 1 AC 1013 [UK]

My Lords, I accept that a defendant who procures a breach of copyright is liable jointly and severally with the infringer for the damages suffered by the plaintiff as a result of the infringement. The defendant is a joint infringer; he intends and procures and shares a common design that infringement shall take place. A defendant may procure an infringement by inducement, incitement or persuasion.

But in the present case Amstrad do not procure infringement by offering for sale a machine which may be used for lawful or unlawful copying and they do not procure infringement by advertising the attractions of their machine to any purchaser who may decide to copy unlawfully. Amstrad are not concerned to procure and cannot procure unlawful copying. The purchaser will not make unlawful copies because he has been induced or incited or persuaded to do so by Amstrad. The purchaser will make unlawful copies for his own use because he chooses to do so. Amstrad’s advertisements may persuade the purchaser to buy an Amstrad machine but will not influence the purchaser’s later decision to infringe copyright.

Buckley L J observed in *Belegging-en Exploitiemaatschappij Lavender B V v Witten Industrial Diamonds Ltd*[1979] FSR at 65, that “facilitating the doing of an act is obviously different from procuring the doing of the act.” Sales and advertisements to the public generally of a machine which may be used for lawful or unlawful purposes, including infringement of copyright, cannot be said to “procure” all breaches of copyright thereafter by members of the public who use the machine. Generally speaking, inducement, incitement or persuasion to infringe must be by a defendant to an individual infringer and must identifiably procure a particular infringement in order to make the defendant liable as a joint infringer.

46. *Authorizing infringement*: Copyright laws usually provide that a defendant who authorizes infringement is liable for such infringement. The problem arises typically in the context of library services and the provision of photocopying machines or facilities. The rule appears to be that a person does not authorize infringement by authorizing the use of equipment that could be used to infringe copyright.³⁵⁶

CCH CANADIAN LTD v LAW SOCIETY OF UPPER CANADA

2004 SCC 13 [Canada]

Authorize means to “sanction, approve and countenance”. Countenance in the context of authorizing copyright infringement must be understood in its strongest dictionary meaning, namely, “give approval to; sanction, permit; favor, encourage”. Authorization is a question of fact that depends on the circumstances of each particular case and can be inferred from acts that are less than direct and positive, including a sufficient degree of indifference.

However, a person does not authorize infringement by authorizing the mere use of equipment that could be used to infringe copyright. Courts should presume that a person who authorizes an activity does so only so far as it is in accordance with the law. This presumption may be rebutted if it is shown that a certain relationship or degree of control existed between the alleged authorizer and the persons who committed the copyright infringement.

TWENTIETH CENTURY FOX FILM CORPORATION & ANOR v NEWZBIN LTD

[2010] EWHC 608 (Ch)

In my judgment it is clear from this passage that “authorize” means the grant or purported grant of the right to do the act complained of. It does not extend to mere enablement, assistance or even encouragement. The grant or purported grant to do the relevant act may be express or implied from all the relevant circumstances. In a case which involves an allegation of authorization by supply, these circumstances may include the nature of the relationship between the alleged authorizer and the primary infringer, whether the equipment or other material supplied constitutes the means used to infringe, whether it is inevitable it will be used to infringe, the degree of control which the supplier retains and whether he has taken any

³⁵⁶ *Roadshow Films Pty Limited v iiNet Limited* [2011] FCAFC 23. In the Miruku case [Japan] it was found that the owner of the karaoke bar is liable for copyright infringement for singing of songs by the customers in the karaoke bar, and at the same time the lessor of the karaoke machine to the owner is liable for contributory infringement of the copyright by leasing the karaoke machine used for accompanying such singing by customers. See Masayoshi Sumida “On the Judgment by the Appellate Court on the Miruku Case”: http://www.cric.or.jp/cric_e/cuj/cuj98/cuj98_3.html.

steps to prevent infringement. These are matters to be taken into account and may or may not be determinative depending upon all the other circumstances.

47. *The liability of landlords for the infringing acts of tenants:* The issue of landlord liability is a contentious issue. It is a possibility in some jurisdictions though the legal basis varies. It is easier to attach civil liability than criminal liability because of the requirement of guilty knowledge and the lesser burden of proof. In general the principles set out in the preceding paragraphs apply.³⁵⁷

FONOVISA, INC. v. CHERRY AUCTION, INC

76 F.3d 259 (9th Cir. 1996)

This is a copyright and trademark enforcement action against the operators of a swap meet, sometimes called a flea market, where third-party vendors routinely sell counterfeit recordings that infringe on the plaintiff's copyrights and trademarks.

For purposes of this appeal, it is undisputed that Cherry Auction operates a swap meet in Fresno, California, similar to many other swap meets in this country where customers come to purchase various merchandise from individual vendors. The vendors pay a daily rental fee to the swap meet operators in exchange for booth space. Cherry Auction supplies parking, conducts advertising and retains the right to exclude any vendor for any reason, at any time, and thus can exclude vendors for patent and trademark infringement. In addition, Cherry Auction receives an entrance fee from each customer who attends the swap meet.

There is also no dispute for purposes of this appeal that Cherry Auction and its operators were aware that vendors in their swap meet were selling counterfeit recordings in violation of Fonovisa's trademarks and copyrights.

Although the Copyright Act does not expressly impose liability on anyone other than direct infringers, courts have long recognized that in certain circumstances, vicarious or contributory liability will be imposed.

Similar principles have also been applied in the trademark field. The Seventh Circuit, for example, has upheld the imposition

357 See also *Louis Vuitton Malletier SA v Texas International Partnership* Case 4:10-cv-02821 (US District Court, Southern District of Texas, Houston Division) 18 November 2011.

of liability for contributory trademark infringement against the owners of a flea market similar to the swap meet operated by Cherry Auction.

Vicarious Copyright Infringement: The concept of vicarious copyright liability was developed as an outgrowth of the agency principles of respondeat superior. Noting that the normal agency rule of respondeat superior imposes liability on an employer for copyright infringements by an employee, the court endeavored to fashion a principle for enforcing copyrights against a defendant whose economic interests were intertwined with the direct infringer's, but who did not actually employ the direct infringer.

The test was more clearly articulated in a later case as follows: "even in the absence of an employer-employee relationship one may be vicariously liable if he has the right and ability to supervise the infringing activity and also has a direct financial interest in such activities."

Contributory Copyright Infringement: Contributory infringement originates in tort law and stems from the notion that one who directly contributes to another's infringement should be held accountable. Contributory infringement has been described as an outgrowth of enterprise liability and imposes liability where one person knowingly contributes to the infringing conduct of another.

There is no question that plaintiff adequately alleged the element of knowledge in this case. The disputed issue is whether plaintiff adequately alleged that Cherry Auction materially contributed to the infringing activity. We have little difficulty in holding that the allegations in this case are sufficient to show material contribution to the infringing activity. Indeed, it would be difficult for the infringing activity to take place in the massive quantities alleged without the support services provided by the swap meet. These services include, *inter alia*, the provision of space, utilities, parking, advertising, plumbing, and customers.

Moreover, we agree with the Third Circuit's analysis in that providing the site and facilities for known infringing activity is sufficient to establish contributory liability.

Contributory Trademark Infringement: Just as liability for copyright infringement can extend beyond those who actually manufacture or sell infringing materials, our law recognizes liability for conduct that assists others in direct trademark infringement. Contributory

trademark liability is applicable if defendant (1) intentionally induces another to infringe on a trademark or (2) continues to supply a product knowing that the recipient is using the product to engage in trademark infringement.

Some countries have special legislation to regulate the matter. In India, for instance, the Copyright Act provides that copyright is deemed to be infringed when any person permits for profit any place to be used for the communication of the work to the public where such communication constitutes an infringement of the copyright in the work, unless he was not aware and had no reasonable ground for believing that such communication to the public would be an infringement of copyright.

48. *Liability of directors: The liability of a director is on the same basis as any other accessory. Where there is a mental element of the tort, it is necessary that the director or senior employee must have the same mental state as is required of the primary tortfeasor.*

FOXTEL MANAGEMENT PTY LIMITED v THE MOD SHOP PTY LTD

[2007] FCA 467

If the directors themselves directed or procured the commission of the act they would be liable in whatever sense they did so, whether expressly or impliedly.

The “procured or directed” test, or “authorised, procured or directed” test, focuses attention on the relationship between the director’s intention and the particular corporate conduct which the law characterises as tortious.

LOUIS VUITTON MALLETTIER S.A. v 486353 B.C. LTD

2008 BCSC 799 (CanLII)

While the personal defendants may attempt to hide behind the Corporation in an effort to avoid liability for the activities carried on at those stores, such a defence is not available here. A corporation cannot be used to shield an officer or director or a principal employee, when that individual’s actions amount to a deliberate, wilful and knowing pursuit of a course of conduct which was likely to constitute infringement or at least where those actions reflect an indifference to the risk of an infringement.

J. COUNTERFEITING IN THE INTERNET AGE³⁵⁸

49. *Online piracy is huge business:* A recent study, according to the International Herald Tribune of 10 June 2011, found that websites offering pirated digital content or counterfeit goods, record 53 billion hits per year. The problem is particularly hard to crack because the villains are often in far-away places. It is difficult to pin them down in the sea of website, and pirates can evade countervailing measures easily by tweaking the name of a website.

According to the US Department of Justice, [G] was a leader of an organized criminal group known as DrinkOrDie, which had a reputation as one of the oldest Internet piracy groups. DrinkOrDie was founded in Russia in 1993 and was dismantled by the US Immigration and Customs Enforcement as part of Operation Buccaneer in December 2001, with more than 70 raids conducted in the US and five foreign countries, including the Australia, Finland, Norway, Sweden and United Kingdom. DrinkOrDie was estimated to have caused the illegal reproduction and distribution of more than \$50 million worth of pirated software, movies, games and music. It specialized in cracking software codes and distributing the cracked versions over the Internet. Its victims included Microsoft, Adobe, Autodesk, Symantec and Novell, as well as smaller companies whose livelihood depended on the sales revenue generated by one or two products. Once cracked, these software versions could be copied, used and distributed without limitation. Members stockpiled the illegal software on huge Internet computer storage sites and used encryption and an array of other sophisticated technological security measures to hide their activities from law enforcement.³⁵⁹

This led to the extradition of G to the USA from Australia in spite of the fact that G had never set foot in the USA.

50. *The search for modern tools:* Traditional rules do not always satisfy the requirements created by the Internet-era. As this judgment shows, the territoriality principle, which applies to IP rights, limits a court's jurisdiction to the territory where the infringement took place.

358 See "Trademarks and Internet" prepared by the WIPO Secretariat in the framework of the 24th session (2010) of the Standing Committee on the Law of Trademarks, Industrial Designs and Geographic Indications (SCT): http://www.wipo.int/edocs/mdocs/sct/en/sct_24/sct_24_4.pdf; "Trademarks and Internet" prepared by the WIPO Secretariat in the framework of the 25th session (2011) of the SCT: http://www.wipo.int/edocs/mdocs/sct/en/sct_25/sct_25_3.pdf; Daniel Seng, Comparative Analysis of the National Approaches to the Liability of Internet Intermediaries: http://www.wipo.int/copyright/en/doc/liability_of_internet_intermediaries.pdf; Lilian Edwards, Role and Responsibility of Internet Intermediaries in the Field of Copyright and Related Rights: http://www.wipo.int/copyright/en/doc/role_and_responsibility_of_the_internet_intermediaries_final.pdf.

359 Michael Blakeney *Policy responses to the involvement of organized crime in intellectual property offences*: http://www.wipo.int/edocs/mdocs/enforcement/en/wipo_ace_5/wipo_ace_5_5.pdf.

PRO SWING INC v ELTA GOLF INC

[2006] 2 S.C.R. 612, 2006 SCC 52

Modern-day commercial transactions require prompt reactions and effective remedies. The advent of the Internet has heightened the need for appropriate tools. On the one hand, frontiers remain relevant to national identity and jurisdiction, but on the other hand, the globalization of commerce and mobility of both people and assets make them less so. The law and the justice system are servants of society, not the reverse. The Court has been asked to change the common law. The case for adapting the common law rule that prevents the enforcement of foreign non-money judgments is compelling. But such changes must be made cautiously. Although I recognize the need for a new rule, it is my view that this case is not the right one for implementing it

Extraterritoriality is a long-recognized concern not only because a law normally applies solely in the jurisdiction where it is enacted, but also because courts lack familiarity with foreign justice systems. Courts will tend to find solutions to limit spheres of conflict.

However, the same extraterritorial application cannot be said of the orders contained in the consent decree and the contempt order that enjoined him from purchasing and selling the material. Since the trademark protection is the one recognized in the U.S. and the Internet transaction took place in both Ohio and Ontario, the transaction can be said to have occurred in Ohio. The Internet component does not transform the U.S. trademark protection into a worldwide one.

Extraterritoriality and comity cannot serve as a substitute for a lack of worldwide trademark protection. The Internet poses new challenges to trademark holders, but equitable jurisdiction cannot solve all their problems. In the future, when considering cases that are likely to result in proceedings in a foreign jurisdiction, judges will no doubt be alerted to the need to be clear as regards territoriality. Until now, this was not an issue because judgments enforcing trademark rights through injunctive relief were, by nature, not exportable.

51. *The Memorandum of Understanding*:³⁶⁰A non-binding Memorandum of Understanding was entered into between rights owners and internet platforms on 4 May 2011 to address the problems relating to the sale of

counterfeit goods via the Internet in the European Union.³⁶¹ The purpose of the memorandum is this:

“The purpose of this Memorandum of Understanding (hereinafter referred to as “MoU”) is to establish a code of practice in the fight against the sale of counterfeit goods over the internet and to enhance collaboration between the signatories including and in addition to Notice and Take-Down procedures. The MoU will also set an example for other stakeholders that are not signatories to this MoU.”

361 As to the position in France: see the Charte Brochand Sirinelli (available at: <http://www.minefe.gouv.fr/actus/pdf/091216charteinternet.pdf>). See the presentation of this charter made by Pr. Sirinelli during the 7th session of the WIPO Advisory Committee on Enforcement: http://www.wipo.int/edocs/mdocs/enforcement/en/wipo_ace_7/wipo_ace_7_8.pdf.

COUNTERFEITING OF TRADEMARK GOODS

CHAPTER XXII

- A. INTRODUCTION (1-3)
- B. INTERNATIONAL OBLIGATIONS (4-8)
- C. REGISTERED TRADEMARKS (9-11)
- D. NATURE OF INFRINGEMENT (12-16)
- E. LACK OF AUTHORIZATION (17)
- F. WILFULNESS (18-21)
- G. COMMERCIAL SCALE (22)

A. INTRODUCTION

1. *Counterfeiting is a crime:* Trademark infringement by means of counterfeiting is a crime while ordinary trademark infringement is merely a statutory civil wrong. Counterfeiting is regarded as a species of fraud. However, counterfeiting is not possible unless the particular action does not also amount to trademark infringement.

R v JOHNSTONE

[2003] UKHL 28 [UK]

Counterfeiting, piracy and bootlegging are not exact terms but all involve deliberate, and generally fraudulent, infringement of various intellectual property rights—notably trademarks, copyright, design right and performing rights.

2. *Counterfeiting defined:* The TRIPS Agreement defines counterfeit trademark goods in a footnote

“to mean any goods, including packaging, bearing without authorization a trademark which is identical to the trademark validly registered in respect of such goods, or which cannot be distinguished in its essential aspects from such a trademark, and which thereby infringes the rights of the owner of the trademark in question under the law of the country of importation.”

For some reason or other the definition is not of general application in the TRIPS Agreement because the definition appears in the context of customs obligations and in a footnote. Although it is useful, the definition is not very satisfactory. The ACTA (Anti-Counterfeiting Trade Agreement) also defines counterfeiting but in a way that emphasizes that trademark rights are territorial:

counterfeit trademark goods means any goods, including packaging, bearing without authorization a trademark which is identical to the trademark validly registered in respect of such goods, or which cannot be distinguished in its essential aspects from such a trademark, and which thereby infringes the rights of the owner of the trademark in question under the law of the country in which the [enforcement] procedures are invoked.

INTA (the International Trademark Association) in its model law defines the term “counterfeit mark” (it uses the synonym “spurious” in line with US practice) in more detail to mean:

“a spurious mark:

(1) that is applied to or used in connection with any goods, services, labels, patches, stickers, wrappers, badges, emblems, medallions, charms, boxes, containers, cans, cases, hangtags, documentation, or packaging or any other components of any type or nature that are designed, marketed, or otherwise intended to be used on or in connection with any goods or services;

(2) that is identical with, or substantially indistinguishable from, a mark registered in this [country] and in use, whether or not the defendant knew such mark was so registered; and

(3) the application or use of which either (i) is likely to cause confusion, to cause mistake, or to deceive; or (ii) otherwise intended to be used on or in connection with the goods or services for which the mark is registered.

3. *Counterfeiting is more than trademark infringement:* All trademark infringement is not counterfeiting. Trademark infringement, in general terms, is committed if the infringer’s mark is so close to the registered mark that there is a likelihood of confusion between the marks. For counterfeiting the likelihood of confusion is generally not enough: the two marks must either be identical or fairly indistinguishable. In other words, the protected goods must be imitated in such manner and to such a degree that the infringing goods are substantially identical copies of the protected goods or a colorable imitation thereof so that the infringing goods are intended to cause confusion.

NOKIA CORPORATION v REVENUE & CUSTOMS

[2009] EWHC 1903 (Ch) (27 July 2009)

It can be seen that the Regulation [EU Council Regulation 1383/03, the “Customs Regulation on IPR Enforcement”] is concerned with three categories of infringing goods, namely “counterfeit goods” which infringe a registered trade mark; “pirated goods” the making of which would have infringed a copyright or design right; and goods which infringe a patent or other miscellaneous rights.

As for “counterfeit goods”, these must bear a mark which is the same or essentially the same as the registered mark and it must be used on goods which are of the same type as those the subject of the registration. It is apparent that this definition includes but is not limited to fakes. It also encompasses the use of the registered mark on goods which are of the same type as those the subject of

the registration even if the trade mark holder is not using the mark on those goods himself. It is, however, limited to goods which, by virtue of the fact they bear the offending mark, infringe the trade mark holder's rights.

B. INTERNATIONAL OBLIGATIONS

4. *The TRIPS provisions:* Art 61 of TRIPS contains the primary obligation to criminalize trademark counterfeiting "in cases of wilful trademark counterfeiting on a commercial scale." The following issues arise in this context:

- The application of the mark to goods and services.
- In order to be entitled to protection the mark must be a registered trademark.
- The registration must be valid.
- Counterfeiting must be without authorization.
- Counterfeiting must be willful.
- Counterfeiting must be on a commercial scale.
- The accused mark must be identical to or indistinguishable in its essential aspects from the registered trademark.

5. *Goods and services:* The TRIPS Agreement requires not only the protection of goods marks against counterfeiting but in addition the protection of service marks. However, because of an interpretation issue, most countries appear to fail to criminalize counterfeit service marks. Others do not appear to distinguish between the two types of marks for present purposes and, accordingly, by implication include service marks while a country such as Singapore does so by way of its definition of a counterfeit trademark, which includes a registered trademark as applied to services.

Countries that rely on Trade Description or Merchandise Marks Acts for dealing with counterfeiting, such as Malaysia, Malta and Nigeria sometimes also criminalize the use of false trade descriptions in relation to services. Whether counterfeiting is possible when the trademark is used on dissimilar goods or services depends on each country's laws.

6. *Local laws:* Each country is obviously entitled to define counterfeiting in its own terms and to prescribe sentences within the limits set by the TRIPS Agreement. Since the most authoritative judgment on the subject came from the House of Lords (now the Supreme Court) in the UK in a judgment on the interpretation of the Trade Marks Act 1994 Chapter 26 it is convenient for illustrative purposes to quote the applicable s 92 (with emphasis added).

(1) A person commits an offence who with a view to gain for himself or another, or with intent to cause loss to another, and without the consent of the proprietor—

(a) applies to goods or their packaging a sign identical to, or likely to be mistaken for, a registered trade mark, or

(b) sells or lets for hire, offers or exposes for sale or hire or distributes goods which bear, or the packaging of which bears, such a sign, or

(c) has in his possession, custody or control in the course of a business any such goods with a view to the doing of anything, by himself or another, which would be an offence under paragraph (b).

(2) A person commits an offence who with a view to gain for himself or another, or with intent to cause loss to another, and without the consent of the proprietor—

(a) applies a sign identical to, or likely to be mistaken for, a registered trade mark to material intended to be used—

- for labelling or packaging goods,
- as a business paper in relation to goods, or
- for advertising goods, or

(b) uses in the course of a business material bearing such a sign for labelling or packaging goods, as a business paper in relation to goods, or for advertising goods, or

(c) has in his possession, custody or control in the course of a business any such material with a view to the doing of anything, by himself or another, which would be an offence under paragraph (b).

(3) A person commits an offence who with a view to gain for himself or another, or with intent to cause loss to another, and without the consent of the proprietor—

- makes an article specifically designed or adapted for making copies of a sign identical to, or likely to be mistaken for, a registered trade mark, or
- has such an article in his possession, custody or control in the course of a business,

knowing or having reason to believe that it has been, or is to be, used to produce goods, or material for labelling or packaging goods, as a business paper in relation to goods, or for advertising goods.

7. *Trademark infringement compared:* This definition should be compared to the two primary civil infringement provisions of s 10 of the UK Act (omitting the dilution provision):

(1) A person infringes a registered trade mark if he uses in the course of trade a sign which is identical with the trade mark in relation to goods or services which are identical with those for which it is registered.

(2) A person infringes a registered trade mark if he uses in the course of trade a sign where, because:

- the sign is identical with the trade mark and is used in relation to goods or services similar to those for which the trade mark is registered, or
- the sign is similar to the trade mark and is used in relation to goods or services identical with or similar to those for which the trade mark is registered,

there exists a likelihood of confusion on the part of the public, which includes the likelihood of association with the trade mark.

R v JOHNSTONE

[2003] UKHL 28

- The prosecution must prove the special *mensrea* of “with a view to gain” (including causing loss to another). There is no civil equivalent.
- The offence-creating provisions apply only in respect of goods (whereas the civil provisions cover goods or services).
- The offence-creating provisions refer to a sign ‘identical to, or likely to be mistaken for’ the registered mark. This is a simpler and narrower formulation than [the civil test of “likelihood of confusion on the part of the public”].
- Section 92(4) combines the functions of parts of sections 10(2) and (3) but differs in substance only if the form of words in sub-section (4) (‘goods in respect of which the trademark is registered’) is narrower than that in s 10(2)(a) (‘identical with or similar to’).
- Section 92(5) has no civil equivalent: a defendant’s belief in his innocence is irrelevant to civil liability.

8. Other laws: Other countries define the prohibited acts somewhat differently. It will serve little purpose to quote more than one and for the sake of convenience the South African statute will be used:

Goods that are counterfeit goods, may not:

- be in the possession or under the control of any person in the course of business for the purpose of dealing in those goods;
- be manufactured, produced or made except for the private and domestic use of the person by whom the goods were manufactured, produced or made;
- be sold, hired out, bartered or exchanged, or be offered or exposed for sale hiring out, barter or exchange;
- be exhibited in public for purposes of trade;
- be distributed: (i) for purposes of trade; or (ii) for any other purpose to such an extent that the owner of an intellectual property right in respect of any particular protected goods suffers prejudice;
- be imported into or through or exported from or through the Republic except if so imported or exported for the private and domestic use of the importer or exporter, respectively; or
- in any other manner be disposed of in the course of trade.

C. REGISTERED TRADEMARK

9. Registered trademark: The second requirement concerns the requirement that the counterfeited trademark must have been registered. For imported goods it means registered in the jurisdiction into which the goods are imported. Otherwise it refers to the jurisdiction where the prohibited dealing takes place.

Typically, as in Singapore, "any person who counterfeits a registered trademark" is guilty of an offense.

Unregistered trademarks are often protected by means of Trade Description or Merchandise Marks Acts. In Malaysia and Nigeria, for example, a false trade description need not relate to a registered trademark

10. Valid registration: Because of a general presumption that a trademark registration is valid, the effect of this requirement for counterfeiting would, generally, mean that the accused must be able to attack the validity of the registration of the mark as a defense to the charge of counterfeiting. But by the very nature of things counterfeiters do not bother with counterfeiting

weak marks – they prefer to use the magnetism of famous and strong marks because that is where the money lies.

Many laws considered do not require a “valid” registration. They define counterfeiting with reference to “registered” trademarks, thereby implying that as long as a mark is on the register it is impermissible to counterfeit it.³⁶²

11. *Testing counterfeiting against the registration certificate:* Should (1) the definition of a “counterfeit” trademark be applied from the standpoint of an average purchaser or an expert, and should (2) the alleged counterfeit mark be compared with the registered mark as it appears on actual merchandise or as it appears on a registration certificate? The judgment below answered the two questions as follows: (1) the comparison should not be by the expert eye and (2) the comparison should be between the trademark as used and not as registered and the counterfeit product. The second answer may be correct in the context of US law but, with respect, appears to be suspect in relation to other laws.

MONTRES ROLEX, S.A v SNYDER

718 F.2d 524

Indeed, one of the distinguishing characteristics of an expert is his ability to see differences that the rest of us do not, and, once the expert sees a difference between the imported object and the registered mark it is unlikely he could find them to be “substantially indistinguishable”.

Consequently, the “expert” test would tend to frustrate the central purpose underlying the amendment: to provide an “effective sanction” against merchandise which “simulates or copies a registered trademark.” In the absence of any more explicit congressional guidance, we believe that the proper course is to adopt the test that ensures the efficacy of the sanction added by the amendment.

Whenever a two-dimensional paper facsimile of a mark like the Rolex crown is compared with the three-dimensional mark fabricated on actual merchandise, some differences will be detectable.

It seems safe to assume that counterfeiters copy actual merchandise, not registration certificates. In this case, for example, the designs on the Grand Jewels bracelets more closely resemble the Rolex mark as it appears on actual merchandise than they do the registered Rolex

362 But see the Indian Trademarks Act 1999 sect 113.

mark. Thus, just as the protected mark on actual merchandise is unlikely to be identical with the two-dimensional facsimile of the mark recorded on the registration certificate, so, too, an infringing mark would be unlikely to be substantially indistinguishable from that facsimile.

D. NATURE OF INFRINGEMENT

12. *Counterfeiting presupposes trademark infringement:* Counterfeiting is by its very nature trademark infringement and there cannot be counterfeiting without infringement. But something more than infringement is required.

“Counterfeit cases involve an infringer attempting to reproduce—and substitute for—the goods (not just the trademark) of the trademark owner. The striking feature about counterfeit cases is that they are legally very simple: they do not involve serious disputes over the boundaries of the trademark owner’s rights. In mimicking the goods and the trademarks, the conduct of counterfeiters clearly falls within the ambit of conduct that a trademark owner is entitled to prevent.”³⁶³

PUMA v RAMPAR TRADING

[2010] ZASCA

It is now necessary to consider whether the shoes were counterfeit. As mentioned above, the answer has to be sought in para (b) of the definition of counterfeiting [in the South African counterfeit Goods Act]. In view of the common cause facts the only remaining issue is whether the marks applied to Rampar’s shoes are ‘the subject matter’ or ‘a colourable imitation’ of any of Puma’s registered trademarks. To be ‘the subject matter’ means, as mentioned, that the Rampar mark must be identical to a Puma trade mark. An ‘imitation’, in turn, is by definition a copy, and the adjective ‘colourable’ reinforces the fact that the copy is counterfeit. In other words, the definition says no more than that a counterfeit must be counterfeit. That is why it must be ‘calculated to be confused with’ or ‘taken as being’ the registered mark and why it involves deliberate and fraudulent infringement of trademarks.

This test is not the same as the standard trade mark infringement test of ‘likely to deceive or cause confusion’ but counterfeiting,

³⁶³ Jason Bosland, Kimberle Weatherall and Paul Jensen *Trademark and counterfeit litigation in Australia*. www.law.unimelb.edu.au/ipria/publications/workingpapers.html.

by its very nature, amounts *a fortiori* to trade mark infringement. Reference during argument to the test to be applied to determine the likelihood of deception and confusion, confusing similarity, to passing-off principles, imperfect recollection, momentary confusion, the prospective purchaser, that a substantial (ie, not negligible) number of people have to be confused, evidence about the public's perception and how Rampar intended to market the goods was, accordingly, singularly out of place and unhelpful.

13. *Actual confusion is not required.*³⁶⁴It is known that many persons buy counterfeit goods willingly. However, an accused may not rely on the fact that the purchaser was not or could not have been misled because, for instance, of the price or low quality of the goods or the location of the seller's premises.

R v BOULTER

[2008] EWCA Crim 2375

The defence statement advanced the following proposed defence:

"The material bearing the trade marks was of such poor quality that no one could think that its trade origin was that of the trade mark owner. Accordingly, the use of the trade marks was not likely to jeopardise the guarantee of origin which constituted the essential function of the trademark rights owned by the trade mark owners. It is therefore denied that what the Defendant undertook constituted a civil infringement of the trademark or, therefore, a criminal offence."

The judge ruled that it was immaterial whether the quality of the counterfeiting was so poor that no-one would think that its trade origin was that of the trademark owner. In the light of that ruling the applicant entered his pleas of guilty.

The applicant argues that in order for there to be a civil infringement there had to be a likelihood of the public being deceived or confused. In our judgment the fatal flaw in this argument is that it overlooks an important distinction between section 10(1) and 10(2). In the case of an alleged section 10(2) infringement giving rise to criminal liability, it would be necessary to establish the likelihood of confusion, but there is no such requirement in a case falling within section 10(1) [dealing with identical marks]. The present case is a

section 10(1) case, for in this instance the trademark, however badly it may have been copied, was identical with the trademark registered by the various proprietors, and the goods which were found in the applicant's possession in the course of his trade were identical with the goods for which those trademarks were registered.

In our judgment, it is impossible to read Parliament as having intended that, where there is straightforward counterfeiting of goods and their registered trademark, it is open to a defendant to advance a defence that the quality was so poor as not to give rise to any risk of confusion, not only because that would fail to recognize the distinction drawn between section 10(1) and 10(2) but it would go a considerable way to assist the vice which Lord Nicholls at any rate thought that Parliament had attempted to combat, namely the counterfeiter who sells his wares as "genuine fakes".

In the present case, it is not and could not seriously be suggested that the use of the EMI logo or other logos was anything other than a replication of those badges as signs of origin registered by the proprietors. It had no other rational purpose. Whether the reproductions were poor, and whether they were actually likely to deceive, is in our judgment neither nor there, and for good reason.

The goods in this case did not involve the use of a trademark for a descriptive purpose but, as already stressed, was pure counterfeiting. It self-evidently damages the registered proprietor of a trademark if that proprietor is not able to control the use of its logo as a badge of origin and if goods of variable quality bearing that stamp are on the market.

The position is the same in the USA as appears from this report:³⁶⁵

"The statute does not require a showing that direct purchasers would be confused, mistaken, or deceived. It is sufficient that there is a likelihood of confusion, mistake, or deception to any member of the buying public, even a person who sees the product after its purchase. Because likelihood of confusion, mistake, or deception applies to members of the general purchasing public and not just to the immediate purchaser, this factor may be present even where the defendant told the immediate purchaser the item was not genuine, or where the sale of counterfeit goods for a fraction of the price of expensive trademarked goods might alert a prospective purchaser that the item was not genuine."

14. *Is cloning required?* The cloning issue can best be described with reference to a simplified example. A trademark is registered in class 25 in relation to clothing, shoes and headgear. The rights owner uses the trademark on shoes only but the alleged counterfeiter uses the identical mark on headgear or on a completely different type of shoe. One can also conceive of a situation where the rights holder has not used the trademark at all. In these cases the infringer (because it will be trademark infringement), although using the identical trademark, did not clone goods bearing a trade mark of the rights holder. Some argue that unless trademarked goods have been cloned they cannot be counterfeited and that cloning of the mark itself and used on goods covered by the mark is not enough.

There is a view that TRIPS requires cloning:³⁶⁶

“The term ‘counterfeiting’ is generally understood to mean the unauthorised manufacture and distribution of copies of such goods and works which are intended to appear to be so similar to the original as to be passed off as genuine examples. This includes use of famous brands on clothing not manufactured by or on behalf of the owner of the trade mark, and exact copies of CDs containing music or software, which are traded in a form intended to be indistinguishable to ordinary consumers from the genuine product.”

The answer depends on the terms of any particular national law. Cloning is for instance not required in South Africa or the USA.

PUMA v RAMPAR TRADING

[2010] ZASCA

Shorn of verbiage [the South African provision] covers any particular class or kind of goods which may bear a registered trade mark, but has not yet been produced or to which it has not yet been applied with the authority of or by the IP owner. In other words, the goods protected are not actual goods but notional goods, ie, goods to which the owner could have applied the trade mark. It means that counterfeiting is possible without cloning and the fact that Puma may not have produced a shoe bearing the particular trade mark does not mean that Rampar’s shoes could not be counterfeited.

Counsel submitted that in spite of the wide wording, [the provisions] should be read to conform to Trips which, it was suggested, does not require such protection.

366 AJ Park & Son for the Ministry of Commerce *Consultant’s Report on Theft of Intellectual Property – Piracy and Counterfeiting*, para B7.

Whatever the general understanding of the term ‘counterfeiting’, or the motive behind the anti-counterfeiting Trips provisions, the limitation is not to be found in Trips or in the clear wording of the Act.

15. The counterfeit mark or packaging must either be identical to or indistinguishable in essential aspects from the registered trademark. This requirement distinguishes counterfeiting from trademark infringement simpliciter. Trademark infringement may amount to counterfeiting but not necessarily so.

“The phrase is intended to prevent a counterfeiter from escaping liability by modifying a protected trademark in trivial ways, while excluding arguable cases of trademark infringement involving trademarks which are merely ‘reminiscent of’ protected trademarks.”³⁶⁷

A mark will, accordingly, be counterfeit if it is either –

- identical to, or
- indistinguishable in its essential aspects from the registered trademark.

The UK statute, for one, follows this wording closely when it speaks of a “sign identical to, or likely to be mistaken for, a registered trademark”. The Singapore Act is similar but is wider when it speaks of “a sign identical to or so nearly resembling a registered trademark as to be calculated to deceive” or the falsification of a genuine registered trademark. (The term “calculated to deceive” has a fixed meaning in common-law jurisdictions. It means “likely to deceive”, the wording used by the New Zealand legislation.)

COLGATE–PALMOLIVE COMPANY v J.M.D. ALL–STAR IMPORT AND EXPORT, INC

486 F.Supp.2d 286

A “counterfeit” is defined as a “spurious mark which is identical with, or substantially indistinguishable from, a registered mark.”

The Second Circuit has stated that an allegedly counterfeit mark must be compared with the registered mark as it appears on actual merchandise to an average purchaser.

When counterfeit marks are involved, it is not necessary to consider the factors which are used to determine whether a mark is a

colorable imitation of a registered mark that creates a likelihood of confusion about its source, because 'counterfeit marks are inherently confusing.'

Cases applying the "substantially indistinguishable" test are inherently fact intensive. In general, however, marks that are similar to the registered mark, but differ by two or more letters, are not likely to be considered counterfeit. (It could not be seriously contended that the average consumer would have found "Amazonas" on shoe heels and soles substantially indistinguishable from "Amazon"; average purchaser would likely not find "Bolivia" watch to be substantially indistinguishable from "Bulova" watch); ("Prastimol" medication not counterfeit of functional equivalent medication sold under the trademark "Mostimol").

On the other hand, marks that are identical to the registered mark as it appears in the marketplace have been held to be counterfeit. ("Montecristo" cigars were counterfeits of plaintiff's cigars bearing that name despite minor differences in the trade dress); (defendants' T-shirts that exactly reproduced PEPE mark as it appeared on plaintiff's T-shirts were counterfeit); (imported bracelets were counterfeit where the differences from plaintiff's bracelets could be detected only with a jeweler's magnifying loupe).

16. *Use as badge of origin.* From the fact that counterfeiting is by its very nature trademark infringement, it follows that the accused must have used the counterfeit mark as a badge of origin, i.e., to indicate a connection in the course of trade between the goods (or, if applicable, services) and the trademark owner. Descriptive use is not infringing use.

R v JOHNSTONE

[2003] UKHL 28

Section 92 [of the UK Trade Marks Act, quoted earlier] is to be interpreted as applying only when the offending sign is used as an indication of trade origin. This is one of the ingredients of each of the offences created by s 92. It must therefore be proved by the prosecution. Whether a sign is so used is a question of fact in each case. The test is how the use of the sign would be perceived by the average consumer of the type of goods in question.

PROCURATOR FISCAL v GALLACHER

[2006] ScotSC 40 [Scotland]

I conclude that before an individual can be convicted in respect of a criminal offence [of counterfeiting], the Crown requires to prove that the registered trademark in question has been infringed in terms of Section 10 of the [UK Trademarks Act]. It is not difficult to reach that conclusion on the basis of the authorities. In *Johnstone*, Lord Nicholls proceeded upon the basis that offending use of the sign had to be ‘use as a trademark’. It is clear that he regarded ‘use as a trademark’ as equating to use ‘as an indication of trade origin’. Similarly, Lord Walker in considering the requirement for ‘trademark use’, agreed with Lord Nicholls.

Importantly, Lord Walker seems to accept the European Court’s view to the effect that ‘...even though the consumer treats the mark as a badge of support for or loyalty to the trademark proprietor’ there will be infringement if the sign is used, without authority, ‘to create the impression that there is a material link in the course of trade between the goods concerned and the trademark proprietor.’

Accordingly, in my opinion, the material consideration, in addressing the issue of infringement, is whether the use complained of was liable to jeopardise the guarantee of origin.

US v PETROSIAN

126 F.3D 1232

Petrosian and two associates purchased genuine Coca-Cola bottles, filled them with a cola-like carbonated beverage that was not Coca-Cola, and told purchasers the beverage was Coca-Cola. Petrosian was charged with violating 18 U.S.C. § 2320(a), which provides: “Whoever intentionally traffics or attempts to traffic in goods or services and knowingly uses a counterfeit mark on or in connection with such goods or services shall” be criminally liable. Petrosian asserts that the district court erred in instructing the jury that “[t]he term ‘counterfeit mark’ includes genuine trademarks, affixed to packaging containing products not made by, but sold as products of the owner of the registered trademark.”

When a genuine trademark is affixed to a counterfeit product, it becomes a spurious mark. A “spurious” mark is one that is false or inauthentic. The Coca-Cola mark became spurious when Petrosian affixed it to the counterfeit cola because the mark falsely indicated

that Coca-Cola was the source of the beverage in the bottles and falsely identified the beverage in the bottles as Coca-Cola.

Obviously, this spurious Coca-Cola mark was “identical with or substantially indistinguishable from” the registered Coca-Cola mark. The spurious mark was also likely to cause confusion because consumers were likely to assume the mark indicated Coca-Cola was the source of the beverage inside the bottle.

E. LACK OF AUTHORIZATION

17. Counterfeiting must be without authorization: The requirement that the use of the trademark must have been without the consent of the proprietor of the registered mark is generally found in all anti-counterfeiting laws. It speaks for itself and is logical because there cannot be infringement of a right if what was done was with the consent of the rights owner.

LEOFELIS SA v LONSDALE SPORTS LTD

[2008] EWCA Civ 640 (1 July 2008)

A trade mark, when registered, is a proprietary right, an item of property; the same is not true, under English law, of a trade mark licence. A licence gives no proprietary interest, and does no more than make lawful some use of the trade mark (or other right) that would otherwise be unlawful. It is a matter of contract.

Implicit in this requirement is that the prosecution must prove that the goods are not original goods, meaning that they did not originate from the trademark owner or his licensee. The effect of this is that the better the counterfeiting the more difficult it is to prove the crime. Detection is becoming increasingly difficult because it is committed:³⁶⁸

- in more than one country;
- in one country, but a substantial part of its preparation, planning, direction or control takes place in another country;
- in one country but may involve an organized criminal group that engages in criminal activities in more than one country; or
- in one country but has substantial effects in another country.

³⁶⁸ *Improvements in the International Legal Framework for Criminal Sanctions against the Offense of Trademark Counterfeiting* 20 June, 2007. www.inta.org/index.

In Nigeria and Singapore, the burden of proving the consent of the proprietor lies on the accused. Although the shift may be useful it ought, generally, not be difficult for the prosecution to establish this element of the crime.

Another implication of this requirement is that the counterfeit mark must at least have been used in connection with the type of goods and services for which the protected mark was registered on or in connection with the defendant's goods or services. In other words, there cannot be counterfeiting unless there is also primary trademark infringement.

F. WILFULNESS

18. *Counterfeiting must be willful.* The minimum TRIPS requirement for counterfeiting is willfulness. A logical definition first envisaged by the European institutions was as follows:³⁶⁹

“‘intentional infringements of an intellectual property right’ means deliberate and conscious infringement of the right concerned for the purpose of obtaining an economic advantage on a commercial scale”.

19. *Willful blindness amounts to willfulness:*

R v BERGE

2007 CanLII 36083 (Ontario S.C.)

This is an appeal by the appellants from their convictions and sentences which followed their trial for various offences involving the sale and distribution of counterfeit Microsoft and Symantec Softwares contrary to the Copyright Act [for “knowingly” selling or offering for sale infringing copies of works in which copyright subsists].

The appellants also submit that the trial judge misdirected himself in law as to the meaning of wilful blindness. In articulating their position, the appellants correctly state the test for wilful blindness as outlined in *R. v. Sansregret*, 1985 CanLII 79 (S.C.C.). In these cases, it has been held that wilful blindness is not just a mere failure to make inquiries in circumstances where a reasonable person would do so; it includes subjective components that make it tantamount to actual knowledge.

³⁶⁹ Proposal of Directive of the European Parliament and of the Council on criminal measures aimed at ensuring the enforcement of intellectual property rights (see <http://www.europarl.europa.eu/sides/getDoc.do?type=TA&reference=P6-TA-2007-0145&language=EN>), eventually withdrawn in 2010 by the European Commission.

I also agree, as submitted by the appellants, that in order to establish wilful blindness, the Crown must establish the following beyond a reasonable doubt:

- That the accused had a subjective realization that a certain fact in question was likely or, at least, “possible above the average”, or that there was a “real suspicion in the mind of the accused that causes the accused to see the need for inquiry”;
- That the accused failed to make the inquiry; and
- That the accused’s purpose in not making the inquiry was to avoid actual knowledge of the suspected fact.

Applying the test formulated above within the context of this case, the Crown had to prove beyond a reasonable doubt that:

The appellant had a real suspicion that the CDs were counterfeit;

He failed to make the appropriate inquiries to confirm or refute this suspicion; and

The specific purpose in failing to make these inquiries was to avoid finding out whether the CD’s were counterfeit.

R. v. Sansregret clarified the legal definition of the concept of recklessness as a basis for criminal liability as well as the legal concept of wilful blindness:

The concept of recklessness as a basis for criminal liability has been the subject of much discussion. Negligence, the failure to take reasonable care, is a creature of the civil-law and is not generally a concept having a place in determining criminal liability. Nevertheless, it is frequently confused with recklessness in the criminal sense and care should be taken to separate the two concepts. Negligence is tested by the objective standard of the reasonable man.

In accordance with well-established principles for the determination of criminal liability, recklessness, to form a part of the criminal *mensrea*, must have an element of the subjective.

R. v. Sansregret (supra) also dealt with the issue of wilful blindness, where he defined its legal concept and applicability:

Where wilful blindness is shown, the law presumes knowledge on the part of the accused. Wilful blindness is distinct from recklessness because, while recklessness involves knowledge of a danger or risk and persistence in a course of conduct which creates a risk that the prohibited result will occur, wilful blindness arises where a person who has become aware of the need for some inquiry declines to make the inquiry because he does not wish to know the truth. He would prefer to remain ignorant. The culpability in recklessness is justified by consciousness of the risk and by proceeding in the face of it, while in wilful blindness it is justified by the accused's fault in deliberately failing to inquire when he knows there is reason for inquiry.

20. *Counterfeiting is an offense of 'near absolute liability'*: Legislatures have, however, chosen to deal with the requirement of *mensrea* (guilty consciousness) in different ways.

In many countries it is for the accused to prove the absence of *mensrea*. In the UK and countries such as Barbados and Jamaica it is a defense that the accused believed on reasonable grounds that the use of the sign in the manner in which it was used, or was to be used, was not an infringement of the registered trademark. From this it follows that the intention to profit or to cause loss must be established by the prosecution but that the accused must prove reasonable grounds for an innocent mindset. However, a lack of intention to infringe is not a defense. In Barbados any trademark infringement is criminal provided it is done knowingly while in Singapore the importation of counterfeit goods is punishable unless the accused can prove his innocent mindset.

R v JOHNSTONE

[2003] UKHL 28

(1) Counterfeiting is fraudulent trading. It is a serious contemporary problem. Counterfeiting has adverse economic effects on genuine trade. It also has adverse effects on consumers, in terms of quality of goods and, sometimes, on the health or safety of consumers. The Commission of the European Communities has noted the scale of this 'widespread phenomenon with a global impact'. Urgent steps are needed to combat counterfeiting and piracy. Protection of consumers and honest manufacturers and traders from counterfeiting is an important policy consideration.

(2) The offences created by s 92 have rightly been described as offences of 'near absolute liability'. The prosecution is not required to prove intent to infringe a registered trademark.

(3) The offences attract a serious level of punishment: a maximum penalty on indictment of an unlimited fine or imprisonment for up to ten years or both, together with the possibility of confiscation and deprivation orders.

(4) Those who trade in brand products are aware of the need to be on guard against counterfeit goods. They are aware of the need to deal with reputable suppliers and keep records and of the risks they take if they do not.

(5) The s 92(5) defence relates to facts within the accused person's own knowledge: his state of mind, and the reasons why he held the belief in question. His sources of supply are known to him.

(6) Conversely, by and large it is to be expected that those who supply traders with counterfeit products, if traceable at all by outside investigators, are unlikely to be co-operative. So, in practice, if the prosecution must prove that a trader acted dishonestly, fewer investigations will be undertaken and fewer prosecutions will take place.

In my view factors (4) and (6) constitute compelling reasons why the s 92(5) defence should place a persuasive burden on the accused person. Taking all the factors mentioned above into account, these reasons justify the loss of protection which will be suffered by the individual. Given the importance and difficulty of combating counterfeiting, and given the comparative ease with which an accused can raise an issue about his honesty, overall it is fair and reasonable to require a trader, should need arise, to prove on the balance of probability that he honestly and reasonably believed the goods were genuine.

HKSAR v LAU HOK TUNG

Hong Kong, China

The three appellants were each convicted of possession for sale or for any purpose of trade or manufacture, of goods to which forged trademarks had been applied, contrary to section 9(2) of the Trades Description Ordinance.

By section 26(4) of the Ordinance a defence is provided to a person charged with an offence under section 9(2). It is as follows:

“In any proceedings for an offence under section 9(2) it shall be a defence for the person charged to prove that he did not know, had no reason to suspect and could not with reasonable diligence have

ascertained, that a forged trade mark had been applied to the goods or that a trade mark or mark so nearly resembling a trade mark as to be calculated to deceive had falsely been applied to the goods.”

Each case is different as to what pro-active steps are required to be taken by a defendant so as to amount to due diligence. It may well be that where a trader has in place a reliable system of procurement which, it can be established has for a long time successfully ensured that only genuine goods are supplied, and there is nothing unusual about a particular transaction, that the trader could successfully rely upon the section 26(4) defence without taking any further precautions; whereas if the transaction or the goods themselves were out of the normal course (perhaps because a different supplier was used, or because the goods were different in nature) it may be that the trader had a higher standard of diligence to meet. In my view issues relevant to the elements of the section 26(4) defence of “no reason to suspect” and “reasonable diligence” may overlap and that where there are aspects of a defendant’s dealings with goods, or of the characteristics of the goods themselves which lie outside that which would be expected in a typical obtaining, possession or sale of genuine goods, then it could well follow that a greater degree of diligence will be required.

In the present case there were aspects of the appellants’ possession of the goods and characteristics of the goods themselves which would as a matter of common sense have required a higher degree of diligence than that which was appropriate to a more typical transaction.

Such matters as the very low price paid for the goods, the fact that they were purchased in assorted batches, that other goods in those batches were regarded as of doubtful provenance, and finally the knowledge of the appellants that the factories in China from which the goods were purchased would or could provide no confirmation of the legitimacy of the goods would, at the least, have required the appellants to have taken matters further. As the magistrate said, had they done so and responded with an appropriate degree of diligence (which simply required them to contact the factories or the agents of the trademark owners) the appellants would have readily discovered the garments were counterfeit. Again as the magistrate said, in this modern day and age with the standard of communication facilities available to businessmen in Hong Kong, that in the present case was not the imposition of too great a degree of diligence.

It should be remembered that, as was said in *R v Multitex (Exports) Ltd* (1996) 4 HKC 422, concerning that which is imported by the concept of reasonable diligence:

“when it is common knowledge that parts off this region have an unhappy reputation for the production of goods with false trade descriptions, there is a very clear and strong burden on businesses in Hong Kong that import goods to ensure that in so far as is at all practicable, the goods they import do not infringe the law. This requires positive action on their part; and the requirements of the section are not fulfilled by an attitude which says that it was not unreasonable to make this assumption or that.”

HKSAR V KONG HING AGENCY LTD

Hong Kong Court of Appeal

For the reasonable diligence defence to apply, it was not enough for an importer or exporter to show on the balance of probabilities that it had no actual knowledge or reason to suspect that the relevant goods bore a false trade description or forged trademark. An accused must also demonstrate that it could not with “reasonable diligence” (not “due diligence” or “all due diligence”) have discovered any false trade description or forgery. This was an objective test and required an examination of what the importer or exporter could have been reasonably expected to have done in the circumstances, not what an importer or exporter in any given case had actually done. The test was subjective only in that one must look at the particular circumstances of the accused.

Here, the reasonable diligence defence was a valid defence. A shipping agent’s duties normally did not concern the goods themselves at all. The shipping agent was not concerned with what the goods were, their quality or the identity of the consignor or consignee. On the other hand, if a typical shipping agent knew or suspected that the goods carried might bear a false trade description or trademark, it would be reasonably expected to make further inquiries or take further action. Here, D’s state of knowledge would not have put it on alert. Accordingly, given D’s normal duties, it had not been required to make further inquiries or to take some other action in relation to the goods and the defence succeeded.

21. *Not all countries require wilfulness:* The prohibited acts in the South African Counterfeit Goods Act, which will serve as an example, have been set out earlier. The commission of those acts are criminal if:

- at the time of the act or conduct, the person knew or had reason to suspect that the goods to which the act or conduct relates, were counterfeit goods; or
- the person failed to take all reasonable steps in order to avoid any act or conduct of the nature contemplated from being performed or engaged in with reference to the counterfeit goods.

G. COMMERCIAL SCALE

22. *Counterfeiting must be on a commercial scale:* Private acts of counterfeiting need not be criminalized – only those done on a commercial scale. The proposal of directive on criminal measures aimed at ensuring the enforcement of intellectual property rights uses this definition:³⁷⁰

“‘infringements on a commercial scale’ means any infringement of an intellectual property right committed to obtain a commercial advantage; this would exclude acts carried out by private users for personal and not for profit purposes”.

Accordingly, most laws are directed at punishing the counterfeiter and the dealer in counterfeit goods. The purchaser of a fake watch, CD or DVD does not commit a crime unless the purchase is with the object of an on-sale. Likewise, a person who for own use makes an otherwise unauthorized copy does not commit the crime of counterfeiting³⁷¹.

R v JOHNSTONE

[2003] UKHL 28

Civil liability arises only in respect of use of a sign ‘in the course of trade’. The equivalent phrase ‘in the course of a business’ appears in s 92 in respect of some, but not all, of the alternative sets of factual ingredients of the offences. An essential ingredient of all the criminal offences created by s 92(1) to (3) is that a person commits an offence where ‘with a view to gain for himself

370 Proposal of Directive of the European Parliament and of the Council on criminal measures aimed at ensuring the enforcement of intellectual property rights (see <http://www.europarl.europa.eu/sides/getDoc.do?type=TA&reference=P6-TA-2007-0145&language=EN>), eventually withdrawn in 2010 by the European Commission.

371 On the notion of commercial scale within the meaning of Article 61 TRIPS, see WTO Panel Report in case DS362 *China – Measures affecting the protection and enforcement of intellectual property rights* (http://www.wto.org/english/tratop_e/dispu_e/362r_e.pdf) and in particular par 7.532 *et seq.*

or another, or with intent to cause loss to another' he does the act in question. With this in mind it is hard to think of a realistic example of conduct which would attract criminal liability and yet be excluded from civil liability because it would not be 'in the course of trade'.

There is, however, a move towards a no tolerance policy and in France, for one, the purchaser or possessor may be guilty of an offence.

PIRACY OF COPYRIGHT GOODS

CHAPTER XXIII

- A. INTRODUCTION (1-7)
- B. PROVING SUBSISTENCE OF COPYRIGHT (8-14)
- C. WITHOUT THE CONSENT OF THE OWNER
OF COPYRIGHT (15)

A. INTRODUCTION

1. *Pirating is more than copyright infringement:* Copyright infringement is essentially a civil wrong. All copyright infringement is not criminalized and copyright infringement is not *per se* piracy. On the other hand, there cannot be piracy without copyright infringement. The effect of this is that before there can be copyright piracy there must be copyright infringement. This definition (adapted for present purposes), contained in the latest ACTA (Anti-Counterfeiting Trade Agreement) text, is accurate:

pirated copyright goods means any goods which are copies made without the consent of the right holder or person duly authorized by the right holder in the country of production and which are made directly or indirectly from an article where the making of that copy would have constituted an infringement of a copyright or a related right under the law of the country in which the [enforcement] procedures are invoked.

2. *The TRIPS obligations:* As mentioned before, TRIPS obliges Member countries to provide for criminal procedures and penalties to be applied at least in cases of willful copyright piracy on a commercial scale. The minimum requirements of Art 61 are accordingly the following:

- There must be an act of copyright piracy.
- The act of copyright piracy must be willful.
- The act of copyright piracy must be on a commercial scale.

Many of these issues were addressed in detail in the previous chapter which deals with trademark counterfeiting to which reference should be made.

3. *Subsistence of copyright:* Part and parcel of any copyright infringement case, whether civil or criminal, is that the subsistence of copyright has to be established and this means that special attention must be given to these elements. The subsistence requirements are these:

- the work must be a protected work;
- it must be original;
- it must be reduced to material form, and
- the copyright must have been conferred because the author was a qualified person or by virtue of first publication in the local jurisdiction or a convention country.

The works protected by means of copyright laws are defined in those laws. The Berne Convention sought to protect literary and artistic works

(Art. 2(1)), which, in terms of the Convention, includes every production in the literary, scientific and artistic domain, whatever may be the mode or form of its expression and then provides a long list of works.

Some works are, because of technology, more prone to piracy and they are (to use non-technical language) printed works or works published on the Internet (photocopying or electronic dissemination), sound recordings (CDs), cinematograph films (DVDs), computer programs, compilations of data and broadcastings.

A discussion of the statutory definitions of what, for instance, literary works are is not really required in this context because these definitions do not really arise in the context of criminal proceedings. The same applies to the other bulleted points, which have been dealt with in an earlier chapter.

4. *The act of piracy must constitute an infringement of a copyright of a particular type:* Anyone who violates any of the exclusive rights of the copyright owner infringes copyright. The position in relation to criminal infringement is generally different.

The TRIPS requirement for pirating is the making of copies that infringe copyright. This, *prima facie*, means that all copyright infringement is not covered, only that consisting of the making of copies. A reproduction or adaptation is often defined in wider terms in local laws as for copying and everything falling there under would not necessarily amount to the making of a copy for purposes of piracy.

Copyright infringement requires a causal connection between the original work and the copy, which means that the fact that one work is the same as the other does not mean that it is copied because both could have been original creations. The one must be derived from the other. In the criminal law context this can hardly ever be an issue of any practical significance. The copy of a film or sound recording or the photocopy of a book could never have been made independently. It is thus unnecessary to consider this matter any further.

Typically only certain circumscribed acts – and not all infringing acts – are criminalized. The acts as defined in the UK legislation are representative:³⁷²

- to make for sale or hire, or
- to import otherwise than for private and domestic use, or

372 Copyright, Design and Patents Act 1988 (C. 48) s 107. There is a similar provision in relation to illicit recordings.

- to possess in the course of a business with a view to committing any act infringing the copyright, or
- in the course of a business:
 - selling or letting for hire, or
 - offering or exposing for sale or hire, or
 - exhibiting in public, or
 - distributing, or
- to distribute otherwise than in the course of a business to such an extent as to affect prejudicially the owner of the copyright, an article which is, an infringing copy of a copyright work.

A few jurisdictions have a more generalized approach to the matter. They criminalize any willful (civil) copyright infringement on a commercial scale. This is the position in the US and in countries that have accepted TRIPS-plus obligations in bilateral trade agreements. In this regard the definition of civil infringement is important. For instance, as in Singapore, it may include an infringement of the communication right as envisaged by Art 8 of the *WCT* and Arts 10 and 14 of the *(WPPT) (1996)*, meaning the right to transmit the work by electronic means and the making available of a work on a network in such a way that it may be accessed by others.

CHAN NAI MING v HKSAR

Final Appeal NO. 3 OF 2007

Hong Kong, China

A 'copy' of a work may exist in electronic or digital form. Section 24(4) expressly refers to issuing copies of a work in electronic form. It is, moreover, important to distinguish between the electronic copy itself and the physical medium in which it resides. Thus, section 23(2) refers to storing a work 'in any medium by electronic means' as an instance of copying. The resultant reproduction of the work, i.e., the copy, is 'in electronic form' consisting of a specific combination of digital data which is 'usable only by electronic means'. The physical storage article is therefore conceptually and physically different from the electronic copy it contains. Obviously, if a further reproduction of the work were to be made from that electronic copy, the resultant copy would constitute a further electronic copy.

In the present case, when the appellant electronically copied a film from the VCD and stored the copy made on his computer's hard disk, he was 'reproducing the work in [a] material form' as provided by section 23(2). The copy was an infringing copy since its making was an infringement of the copyright in the film, as stipulated by

section 35(2). Each copy was also a copy in electronic form as it was only usable by electronic means. If it were to be further reproduced, the resultant electronic copies would also be infringing copies of the protected work.

I agree of course that an electronic copy must exist in some physical medium or environment and not in a vacuum. But as the evidence established and as everyday experience indicates, electronic data constituting a digital copy of a work can plainly be transmitted via the medium of the network of computers and cables making up the internet. Electronic copies can thus plainly be transmitted without first being stored in a tangible article such as a CD or DVD to be physically handed over to a recipient.

It is of course true that an electronic copy will often be stored in a disk or some similar tangible object which is capable of and intended for physical delivery. But use of such a storage device is not an essential condition for the transfer or distribution of an electronic copy. An internet network made up of linked computers is no less tangible and effective a medium for its transmission.

- 5.** *The act of piracy must be willful.* Willfulness is a minimum requirement. The meaning of the term has been dealt with in detail in the previous chapter.

The UK requires knowledge or reason to believe that the act amounts to an infringement of copyright³⁷³ but the criminal liability for making, dealing with or using illicit recording appears to be absolute and not dependent on willfulness. Hong Kong law does not require willfulness; instead it creates a defense for the person charged to prove that he did not know and had no reason to believe that the copy in question was an infringing copy of the copyright work. Singapore requires for primary infringement that the accused knows, or ought reasonably to know that he is dealing with an infringing copy and the same applies to the importation of infringing goods and the other prohibited acts.

- 6.** *Proof of knowledge:* Knowledge on the part of the accused may be established through circumstantial evidence.

“The requisite showing of knowledge, or willful blindness, may be made through direct or circumstantial evidence. The Seventh Circuit noted that the defendant ‘knew that the marks were on the bottles, caps and boxes’, and found this knowledge to be sufficient

to uphold a conviction. Typical circumstantial evidence includes, but is not limited to, evidence of a defendant's purchase or sale of the goods, manipulation of the goods, the method of delivery, packaging conventions, or an unusually low price. Indeed, the profits and circumstantial evidence regarding knowledge are usually so overwhelming that this element is not often contested."³⁷⁴

7. *The act of piracy must be on a commercial scale:* Different laws use different formulations. The US law requires infringement "for purposes of commercial advantage or private financial gain"³⁷⁵ and draws a distinction between for-profit and non-profit infringement, both of which can be criminal depending on the presence of other factors.

Many countries (including Hong Kong and Singapore) follow the example of the UK which, generally, requires copying for commercial purposes (which may not be the same as on a commercial scale) save with two exceptions: importation otherwise than for private and domestic use³⁷⁶ and distribution (in the sense discussed above) otherwise than in the course of a business to such an extent as to affect prejudicially the owner of the copyright, an article which is, an infringing copy of a copyright work.³⁷⁷

B. PROVING SUBSISTENCE OF COPYRIGHT

8. *Proof of subsistence of copyright:* It will immediately be clear that proving subsistence of copyright can be bothersome. It is consequently not surprising that most laws contain special provisions for alleviating this problem. There are three models but they are not self-excluding:

- registration (notification),
- affidavit evidence, and
- presumptions.

Not all copyright presumptions apply necessarily to criminal cases. Whether they do so apply depends upon the laws of each country.

9. *Registration:* Registration is not – and may not be – a requirement for subsistence of copyright but, if provided for in the laws of a country, it

374 *Prosecuting Intellectual Property Crimes*, U.S. Department of Justice Executive Office for United States Attorneys Manual: www.usdoj.gov/criminal/cybercrime/ipmanual.

375 Title 17 para 506.

376 Cf the Danish judgment in *Rolex v Invest ApS of 24 October 2006*: domstol.fe1.tangora.com.

377 On the notion of « commercial scale » within the meaning of Article 61 TRIPS, see WTO Panel Report in case DS362 *China – Measures affecting the protection and enforcement of intellectual property rights* (http://www.wto.org/english/tratop_e/dispu_e/362r_e.pdf).

may provide *prima facie* evidence of subsistence. The USA, which formerly required registration for subsistence, permits registration, which serves the mentioned purpose because a certificate of registration made before or within five years after first publication of the work constitutes *prima facie* evidence of the validity of the copyright.³⁷⁸

Registration or pre-registration is apparently still a requirement for the institution of civil-lawsuits [by US citizens]. Whether it is a requirement for criminal prosecutions is unclear and the courts have decided the matter differently.³⁷⁹

South African law also provides in separate legislation³⁸⁰ for the registration of copyright but only in relation to cinematographic films (as defined in the Copyright Act). The purpose of registration is to facilitate proof in both civil and criminal case of the subsistence of copyright.³⁸¹ The Act provides for a transparent process for registration because the application has to be advertised and may be opposed. The registration may also be revoked on application.³⁸²

10. Affidavit evidence: Systems that generally only permit oral evidence in relation to disputed issues do allow for the use of affidavit evidence to establish subsistence of copyright.

Australian and Singapore law, for instance, allow affidavit evidence in civil as well as criminal proceedings. This evidence may establish that:

- at a particular time, copyright subsisted in the work or other subject matter to which the proceeding relates; or
- at a particular time, copyright in that work or subject matter was owned by, or exclusively licensed to, a particular person; or

378 US Department of Justice's Trafficking In Counterfeit Trademarks, Service Marks, and Certification Marks -18 U.S.C. § 2320": www.cybercrime.gov/18usc2320.htm: "Once the certificate of registration is introduced by the government and accepted as authentic by the court, the burden shifts to the defendant to prove that the copyright is not valid or that the registration was obtained fraudulently, . . . after which the prosecutor may rebut with evidence showing that the certificate is genuine, the registration was properly obtained, or otherwise that the copyright is valid. If the work was registered more than five years after its first publication, the certificate's probative value is left to the court's discretion."

379 *United States v. Cleveland*, 281 F. 249,253 (S.D. Ala. 1922) against *United States v. Backer*, 134 F.2d 533, 535-36 (2d Cir. 1943).

380 Registration of Copyright in Cinematograph Films Act, 1977.

381 "In all civil and criminal proceedings relating to copyright in cinematograph films, the fact that a person is registered as the owner or licensee of the copyright in a cinematograph film shall be prima facie evidence of the validity of the original registration of that copyright and of all subsequent assignments and transmissions thereof."

382 Hong Kong law allows for a copyright register to be provided by means of regulation but registration does not, apparently, dispose of the requirement of an affidavit although the affidavit need not be as expansive as otherwise. See the discussion below.

- at a particular time, copyright in that work or subject matter was not owned by, or exclusively licensed to, a particular person; or
- a particular act was done without the license of the owner of the copyright, or of the exclusive licensee of the copyright, in that work or subject matter.

The respondent is entitled to apply in good faith for the cross-examination of the deponent to the affidavit. If this leave is granted, the affidavit may not be used unless the deponent appears as a witness for cross-examination or the court, in its discretion, permits the affidavit to be used without the deponent appearing.

The legislation applicable in Hong Kong is probably the most detailed and specific. It permits an affidavit which purports to have been made by or on behalf of the owner of a copyright work and which states:

- the date and place that the work was made or first published;
- the name, domicile, residence or right of abode of the author of the work;
- the name of the owner of the work;
- that copyright subsists in the work; and
- that a copy of the work exhibited to the affidavit is a true copy of the work.

In the absence of evidence to the contrary it is presumed that the statements made in the affidavit are true; and that the affidavit was properly made and authenticated. The affidavit must be provided before the hearing to the respondent who may, also before the hearing, serve a notice requiring the attendance of the deponent to the affidavit in court. The deponent must testify orally if the court is satisfied that the subsistence or ownership of the copyright is genuinely in issue.

11. *Presumptions – the Berne requirements:* Lastly, there are some relevant presumptions having their origin in the Berne Convention (Art. 15):

- In order that the author of a literary or artistic work protected by this Convention shall, in the absence of proof to the contrary, be regarded as such, and consequently be entitled to institute infringement proceedings in the countries of the Union, it is sufficient for his name to appear on the work in the usual manner. This provision is applicable even if this name is a pseudonym, where the pseudonym adopted by the author leaves no doubt as to his identity.

- The person or body corporate whose name appears on a cinematographic work in the usual manner must, in the absence of proof to the contrary, be presumed to be the maker of the said work.
- In the case of anonymous and pseudonymous works the publisher whose name appears on the work must, in the absence of proof to the contrary, be deemed to represent the author, and in this capacity entitled to protect and enforce the author's rights. These provisions cease to apply when the author reveals his identity and establishes his claim to authorship of the work.
- In the case of unpublished works where the identity of the author is unknown, but where there is every ground to presume that he is a national of a country of the Union, it is a matter for legislation in that country to designate the competent authority who may represent the author and be entitled to protect and enforce his rights.

12. *A typical statutory example:* A typical example of the application of this provision is to be found in the Australian Copyright Act (s 132A). It applies to criminal proceedings and provides for instance that if a copy of the work or the packaging or container in which the copy is packaged or contained, bears a label or mark stating

- the year and place of the first publication, or of the making, of the work, then that year and place are presumed to be as stated on the label or mark,
- that a particular person was the owner of copyright in the work at a particular time, that person is presumed to have been the owner of the copyright at the time,

unless the contrary is established.

13. *Presumptions in relation to computer programs:* There are other presumptions of a like nature but it ought to suffice to refer to those applicable to computer programs. If articles embodying a program have been supplied (by sale or otherwise) to the public; and at the time they, or their containers, bore a label or other mark consisting of © accompanied by a specified year and the name of a person, it is presumed that the computer program is an original work, was first published in that year; and the person was the owner of copyright in the program when and where the articles, things or containers were labeled or marked.

14. *Application of presumptions:* This judgment is cited as an example of the application of some of the presumptions contained in the Australian legislation.

MICROSOFT CORPORATION v PC CLUB AUSTRALIA PTY LTD

[2005] FCA 1522 [Australia]

By virtue of the respondents' denial of both subsistence of copyright in *Windows XP Home* and *Windows XP Pro* and Microsoft's ownership thereof, subsistence and ownership were placed in issue in the current proceedings: see again pars (a) and (b) of s 126 of the *Copyright Act*.³⁸³ For the purpose of establishing subsistence and ownership of copyright in those programs the applicants have relied upon the presumptions contained in s 128 of the *Copyright Act* and additionally, or at least in the alternative, on the evidentiary provisions ss 126A³⁸⁴ and 126B.

Section 128³⁸⁵ was considered in *DHD Distribution*, a case similarly involving Microsoft computer programs. Lehane J was there presented with original copies of the relevant programs as first published. Having been satisfied that those computer programs were first published in the United States within the 50 year period prescribed by s 128(a) of the *Copyright Act*, his Honour then considered what was required under s 128(b) to prove that those original copies bore the *name purporting to be that of the publisher*. Lehane J found it significant that those copies of the computer program, as it was first published, made explicit reference to 'Microsoft Corporation' as the owner of copyright in the programs. Accordingly his Honour concluded that those references to 'Microsoft

383 Section 126:

In an action brought by virtue of this Part:

- (a) copyright shall be presumed to subsist in the work or other subjectmatter to which the action relates if the defendant does not put in issue the question whether copyright subsists in the work or other subjectmatter; and
- (b) where the subsistence of the copyright is established--the plaintiff shall be presumed to be the owner of the copyright if he or she claims to be the owner of the copyright and the defendant does not put in issue the question of his or her ownership.

384 Section 126A: (1) This section applies to an action under this Part in which the defendant puts in issue the question whether copyright subsists in the work or other subject matter to which the action relates.

(2) If a copy of the work or other subject matter, or the packaging or container in which the copy is packaged or contained, bears a label or mark stating the year and place of the first publication, or of the making, of the work or other subject matter, then that year and place are presumed to be as stated on the label or mark, unless the contrary is established.

(3) If a certificate or other document issued in a qualifying country in accordance with a law of that country states the year and place of the first publication, or of the making, of the work or other subject matter, then that year and place are presumed to be as stated in the certificate or document, unless the contrary is established.

(4) For the purposes of this section, a document purporting to be a certificate or document referred to in subsection (3) is, unless the contrary intention is established, taken to be such a certificate or document.

385 Section 128: Where, in an action brought by virtue of this Part in relation to a literary, dramatic, musical or artistic work, the last preceding section does not apply, but it is established:

- (a) that the work was first published in Australia and was so published during the period of 70 years that ended immediately before the commencement of the calendar year in which the action was brought; and
- (b) that a name purporting to be that of the publisher appeared on copies of the work as first published; then, unless the contrary is established, copyright shall be presumed to subsist in the work and the person whose name so appeared shall be presumed to have been the owner of that copyright at the time of the publication.

Corporation' were 'plainly references to the first applicant as a person who has issued or caused to be issued copies of the works, as they were first published', and hence Microsoft Corporation was entitled to the benefit of the s 128 presumptions as to subsistence of copyright and ownership of the same in those programs.

Likewise, I am satisfied that the evidence tendered by the applicants establishes Microsoft's ability to rely upon the presumptions contained in s 128. Pursuant to s 126A(3) of the *Copyright Act*, the United States certificate of registration of copyright in *Windows XP Pro* (that program wholly subsuming *Windows XP Home* as earlier pointed out constituted) is *prima facie* evidence of the facts stated therein, that is, that *Microsoft Windows XP Pro* (and as a corollary, also *Windows XP Home*) was first published in the United States on 25 October 2001, which is well within the 50 year period prescribed by s 128(a). As the United States is a Convention country, s 184 of the *Copyright Act* and reg 4 of the *Copyright Regulations* have the effect of applying the operation of s 128 to literary works first published in the United States. Furthermore, I find that the name of Microsoft, who purports to be the entity who has issued or caused to be issued copies of the relevant programs, duly appeared on copies of the programs and their packaging as first published, and was also stated to be the owner of the copyright therein, as was the case in *DHD Distribution*. Accordingly I must conclude that copyright subsists in *Windows XP Home* and *Windows XP Pro*, and further that Microsoft is the owner of that copyright, unless I should find that the contrary has been established by the respondents.

Both parties made submissions to the effect that the *prima facie* case that each had respectively established had the effect of shifting the burden of proof to the other. It was the applicants' submission that having discharged the evidentiary burden of bringing into operation ss 126A, 126B and 128, it necessarily remained for the respondents to adduce sufficient evidence to extirpate the presumptions triggered respectively by those provisions.

The applicants urged that the words *unless the contrary is established* appearing in s 128 have the effect that the presumptions of subsistence and ownership in favour of the entity, whose name appeared on copies of the work first published, would stand unless the contrary was proved on the balance of probabilities. So much was not disputed by the respondents and correctly so in my view.

The standard of proof necessary to be achieved by the respondents to assail the *prima facie* evidentiary provisions of ss 126A and 126B is less straightforward. [After discussion] I accept the applicants' case that once enlivened, the presumptions of subsistence and ownership arising under s 128 stood, unless and until the respondents were to adduce evidence which would prove, on the balance of probabilities, that copyright did not subsist in the relevant programs, and that Microsoft was not the owner thereof.

C. WITHOUT THE CONSENT OF THE OWNER OF COPYRIGHT

15. *Copying must be without the authorization of the right holder.* Copyright infringement is usually defined as an act committed without the consent of the rights holder. Copying with consent cannot be wrongful. Onus is important here, as for other possible defenses. On first principles the prosecution to prove lack of consent and also lack of fair dealing.³⁸⁶

POSITIVE ATTITUDE SAFETY SYSTEMS INC v ALBIAN SANDS ENERGY INC

2005 FCA 332

Copyright is defined in terms of the absence of the consent of the owner of the copyright. Consequently, proof of copyright infringement requires proof of lack of consent. It is therefore illogical to conclude that there has been infringement, subject to the effect of a purported license. It may be that a party has done something which, by the terms of the *Copyright Act*, only the owner of the copyright may do. But, before that conduct can be defined as infringement, the judge must find that the owner of the copyright did not consent to that conduct.

³⁸⁶ *R. v. Laurier Office Mart Inc.* (1994), 58 C.P.R. (3d) 403, aff'd (1995), 63 C.P.R. (3d) 229 (Ont.). But see *Aga Khan v Tajdin* 2011 FC 14. These judgments are all Canadian.

SENTENCING

CHAPTER XXIV

1. Introduction: In terms of Art 61 of the TRIPS Agreement, Member countries have to provide for remedies for counterfeiting and piracy, which must include imprisonment and/or monetary fines, sufficient to provide a deterrent, consistently with the level of penalties applied for crimes of a corresponding gravity.

It follows from this that the drafters of TRIPS regarded deterrence as the main purpose of criminal sanctions.

It is also clear from the wording of the article that the level of penalties has to be comparable to those for crimes of a corresponding gravity. The TRIPS Agreement does not, however, state what those other crimes are and it is left to Member countries to identify them. By the very nature of counterfeiting and piracy it is to be expected that the comparable crimes are commercial crimes such as fraud and the like.

2. Different approaches to sentencing. Sentence levels and sentencing attitudes differ from society to society. It is impossible to make any sensible comparisons to draw any meaningful conclusions. The following quotation from a press release by the European Parliament stated the problem in support of its attempt to harmonize the criminal laws of the Community:³⁸⁷

“At present maximum fines for violating intellectual property rights range from £586 in Greece to £67,000 in Holland. Maximum prison sentences range from three months in Greece to 10 years in Britain.”

3. The judicial approach to sentencing: Subject to statutory prescriptions, it remains the task of a court to impose the sentence which it thinks suitable in the circumstances.

“What has to be considered is the triad consisting of the crime, the offender and the interests of society.”

4. The aims of punishment: Courts must have regard to the purposes which punishment should serve, namely deterrence including prevention, reformation and retribution.

“Deterrence has variously been referred to as the ‘essential’, ‘all important’, ‘paramount’ and ‘universally admitted’ object of punishment. The other objects are accessory.”³⁸⁸

387 Press release of 25 April 2007.

388 *S v Nkambule* 1993 (1) SA 136 (A).

Others are more sceptical. Hannah Arendt was one:

“No punishment has ever possessed enough power of deterrence to prevent the commission of crimes. On the contrary, whatever the punishment, once a specific crime has appeared for the first time, its reappearance is more likely than its initial emergence could ever have been.”

5. *A balanced approach to punishment:* This is not something new. An old Dutch writer once said that among the faults of judges are, on the one hand, severity and, on the other, misplaced pity. Cicero, the advocate, had much to say about the subject. For instance:

“Let the punishment be equal with the offence.”

“Care should be taken that the punishment does not exceed the guilt.”

“Anger should be especially contained in punishing, because he who comes to punishment in wrath will never hold that middle course which lies between the too much and the too little.”

6. *Deterrence:* One may safely say that the possibility of high sentences does not, without more, have any material deterrent effect.

“Deterrence has two aspects: deterring the prisoner and deterring others. The effectiveness of the latter is unclear but, according to judicial precedent, it remains an important consideration. As far as deterring the accused is concerned, it should be borne in mind that ‘there is no reason to believe that the deterrent effect of a prison sentence is *always* proportionate to its length’.”³⁸⁹

7. *The law of diminishing returns:*

“Indeed, it would seem to be likely that in this field there operates a law of diminishing returns: a point is reached after which additions to the length of a sentence produce progressively smaller increases in deterrent effect.”³⁹⁰

8. *Certainty of detection and conviction:* Prescribed sentences have in the abstract no value. The deterring effect of sentences depends on the certainty of detection and conviction. Unless the police are properly equipped and

389 *S v Mlakaza* 1997 (1) SACR 515 (SCA).

390 *S v Skenjana* 1985 (3) SA 51 (A).

able to investigate all crime within a reasonable time and bring the case to court and unless the court system is effective no sentence can have any deterrent value. A criminal commits a crime on the supposition that he will not be caught. The more realistic this supposition the more motivation there is for ignoring laws and committing crimes. The imposition of a sentence of imprisonment in Hong Kong and Singapore for peer-to-peer infringement created some shock waves, at least in the popular press.

“It appears to me to be an inherent probability that the more successful the police are in solving serious crimes and the more successful they are in apprehending the criminals concerned and securing their convictions, the greater will be the perception of risk for those contemplating such offences. That increase in the perception of risk, contemplated by the offender, would bear a relationship to the rate at which serious offences are committed. Successful arrest and conviction must operate as a deterrent and the State should, within the limits of its undoubtedly constrained resources, seek to deter serious crime by adequate remuneration for the police force; by incentives to improve their training and skill; by augmenting their numbers in key areas; and by facilitating their legitimacy in the perception of the communities in which they work.”³⁹¹

This view can be justified with reference to the facts as this extract shows:³⁹²

“No matter how great the punishment, deterrence is difficult to achieve if the criminal’s fear of being prosecuted is low. The FDA reports that, in 2000, it opened six counterfeit drug cases; that number has steadily increased, with fifty-eight counterfeit drug cases being opened in 2004. While the FDA is presumably doing extremely well with the resources it has at its disposal, it is not equipped to investigate and prosecute every instance of drug counterfeiting or misbranding (or even a significant percentage of them).

By one estimate, U.S. citizens are spending approximately \$1 billion annually on Internet pharmacy purchases alone. Given the volume of drugs being sold, particularly in the online medium, it seems unlikely that the fifty-eight reported cases in 2004 represents a significant percentage of the actual number of cases of counterfeiting. Increased criminal penalties probably would not have a significant impact without corresponding increased resources to ensure that the law was enforced.”

391 *S v Makwanyane* [1995] ZACC 3.

392 Sandra L. Rierson Pharmaceutical Counterfeiting and the Puzzle of Remedies 8 *Wake Forest Intellectual Property LJ* 433 (2008): <http://ssrn.com/abstract=1265885>.

9. *Public opinion:*

“The object of sentencing is not to satisfy public opinion but to serve the public interest. A sentencing policy that caters predominantly, or exclusively, for public opinion is inherently flawed. It remains the court’s duty to impose fearlessly an appropriate and fair sentence even if the sentence does not satisfy the public. Public opinion may have some relevance to the enquiry, but, in itself, it is no substitute for the duty vested in the court; the court cannot allow itself to be diverted from its duty to act as an independent arbiter by making choices on the basis that they will find favour with the public.”³⁹³

10. *Proportionality:* Andreas Rahmatian adds this perspective:³⁹⁴

“Sentencing practice for trade mark crimes should not neglect the issue of proportionality. Too severe penalties may not deter, but even encourage counterfeiting at a larger scale (because taking the risk of harsh punishment only pays off in relation to larger operations), and they may undermine public respect and acceptance of trade mark and criminal law alike: ‘If the death penalty is imposed for both small and considerable thefts [quoting Voltaire], it is obvious that [the offenders] will try to steal much. They may even become murderers if they believe that this is a means not to be detected. All that proves the profound truth that a severe law sometimes produces crimes.’ What Voltaire wrote in relation to theft in 1766, is also valid in relation to intellectual property offences today.”

Irina D. Manta writes the following:³⁹⁵

“The empirical data on norms and copyright infringement suggests that harsh sanctions, including criminal ones, may be ineffective in promoting lawful behavior. For instance, some studies have found that “[s]trong-armed enforcement tactics induce strong anti-copyright aversion,” and therefore excessive sanctions can actually prove counterproductive. It also appears that while lawsuits against file-sharers temporarily led to a decrease in illegal downloads, that number rebounded within a short period of time. Meanwhile, other data raises the question whether increasing criminal penalties truly encourages more innovation by making authors feel more secure in their ownership rights; one study that measured, among other

393 *S v Mlaka* 1997 (1) SACR 515 (SCA).

394 Andreas Rahmatian Trade Mark Infringement as a Criminal Offence *Modern Law Review* 67 (4), 670–683.

395 The Puzzle of Criminal Sanctions for Intellectual Property Infringement 24 *Harvard Journal of Law & Technology* 269 (2011).

things, the relationship between increases in criminal sanctions and innovation found no clear effect.”

11. Moral culpability: Sandra L Rierson correctly points out that the legislative justification for severe sentences is based on the perceived harm to the public but that the harm depends on the nature of the counterfeiting and that generalizations are inapposite. She said:³⁹⁶

“In both the civil and criminal context, a ‘counterfeit’ trademark is defined as a ‘spurious mark’ that is ‘identical with, or substantially indistinguishable from, a registered mark,’ and whose use is ‘likely to cause confusion.’ Merely infringing marks are not that different. In terms of available remedies, however, the counterfeit mark and the mark that merely infringes sharply diverge.

The current statutory regime both over- and under-compensates plaintiffs who are the victims of what is loosely termed ‘counterfeiting’. Similarly, in the criminal context, defendants are both over- and under-penalized for trafficking in counterfeit goods. The type of goods involved, as well as the nature and degree of deception perpetrated, should be considered when labeling a particular activity “counterfeiting” and the range of available penalties and remedies should be adjusted accordingly. The defendant who sells a \$25 “Rolex” to a bargain-hunting consumer should not be in the same category with the defendant who sells a \$25 sugar pill labelled AZT to a sick and unsuspecting AIDS patient.

The respective levels of moral culpability and economic harm perpetrated by these two defendants are not remotely comparable.

When Congress criminalized trademark counterfeiting, its *primary* reason for doing so was not to save the nation from a flood of fake Gucci purses. Instead, the legislative history indicates that Congress focused on counterfeits that pose a danger to American consumers.

More recent amendments strengthening the TCA have similarly cited low-quality counterfeits that pose a danger to consumers (e.g., automotive parts, cosmetics, fertilizers, chemicals, sporting goods, electronic equipment, and medical devices) as evidence that such heightened penalties are warranted.”

396 Sandra L. Rierson Pharmaceutical Counterfeiting and the Puzzle of Remedies 8 *Wake Forest Intellectual Property LJ* 433 (2008): ssrn.com/abstract=1265885.

12. Sentencing guidelines. *The South African Counterfeit Goods Act*, after prescribing maxima, contains the following list of useful sentencing guidelines:

- In aggravation of sentence, a court is obliged take into account any risk to human or animal life, health or safety or danger to property that may arise from the presence or use of the counterfeit goods in question.
- In mitigation of sentence, evidence is admissible that the accused, fully, truthfully and to the best of his ability had disclosed to the investigator all information and particulars available to him in relation to:
 - the source from which the counterfeit goods were obtained;
 - the identity of the persons involved in the importation, exportation, manufacture, production or making;
 - the identity and, if reasonably demanded, the addresses or whereabouts of the persons involved in the distribution; and
 - the channels of distribution.

13. Determining the value of counterfeit goods for purposes of sentencing: The street value of counterfeit goods and the value of the originals may differ substantially. In determining sentence, a US court used the following approach:³⁹⁷

“Diallo was caught with over three hundred items of clothing, jewelry, and handbags. All of these items bore the trademarks of several luxury designers, particularly Louis Vuitton. Diallo was found guilty of trafficking in goods bearing counterfeit trademarks.

Prosecutors asked the court to impose a sentence based on the cost of the genuine versions of the goods that Diallo sold. Diallo’s lawyers “argued that the sentence should be based on what Diallo would have sold the counterfeits for.

US District Court Judge Nora Barry Fischer agreed with the defendant and applied the street value in determining the infringement amount. Notably, the court found that

‘given the context of the purchase of the items (i.e. at a flea market) and the price of the items, such items could not appear to a reasonably informed purchaser to be identical or

³⁹⁷ *Valuation of counterfeit goods for purposes of sentencing (especially where there are sentencing guidelines)*
77 Fordham L. Rev. 1147 (2008-2009).

substantially equivalent to the infringed items” and also concluded that the retail value “does not provide an accurate assessment of the pecuniary harm to the copyright or trademark owner.’

Instead the street value ‘provides a more accurate assessment of the harm.’ Moreover, the Court used the fact that Diallo was selling the counterfeit items at a price that was ‘significantly less than 75 per cent of the price of the infringed items’ to show that you could not invoke retail value under the Sentencing Guidelines. The choice of valuation made a significant effect on the sentencing outcome.”

14. *Seriousness of piracy:* These extracts from judgments provide examples of how courts approach sentencing.

HKSAR v CHAN NAI MING

Hong Kong Magistrates’ Court

I must say this first of all: that Hong Kong carefully guards intellectual property rights. These rights are not illusory; they are not something which exists only in theory and not in practice. They are real, they are valuable and they amount to genuine property. And the owners of those rights are entitled to the same level of protection from dishonest appropriation as the owners of ordinary, more tangible property. What is created by or on behalf of the owners of copyright is theirs to deal with and dispose of as they choose. It is not up to others to dictate how they should do so or at what price. It is not open to others to make moral judgments about the price of a book or a DVD or a music CD, and claim that it is excessive, as some form of justification for infringing the copyright. The law does not accord any validity to such attempts to justify copyright piracy.

The practical application of this principle, when the courts are dealing with persons who criminally infringe copyright, is to apply a firm, deterrent based sentencing policy. This is nothing new. There are many decided cases of higher courts which have, time after time, affirmed this approach. In particular, in 1999, in a case called *Choi Sai-lok*, the Court of Appeal approved the comments of a judge in an earlier case when he said, “The victims are the proprietors of the intellectual property whose rights are being violated. There is international pressure upon Hong Kong to stamp out traffic in pirated goods. Failure to attack th[is] illegal activity ... would be perceived as a default on the part of the government on its international obligations.”

This provided the foundation for the approach of the Court of Appeal in *Choi Sai-lok* because it went on to say, “We emphasize that custodial sentences of immediate effect [i.e. not suspended sentences] should be imposed for offences of this kind unless the circumstances can be said to be truly exceptional ... The open flouting of the law in this trade requires sentences, even for first offenders, to act as a deterrent to others.”

This was, as I have found, at least an attempted distribution of the infringing copies to such an extent as to affect prejudicially the owners of the copyright. It was done in a public, open forum where anyone with the appropriate equipment could download. It is proper to infer that some copies of films obtained by downloaders in this manner would themselves be downloaded to others. The potential for prejudice to the copyright owners by this latent risk of re-distribution, beyond those who initially take the seeded film, is extensive.

PUBLIC PROSECUTOR v MD HAPIZ BIN TAHIR

[2007] SGDC 40 [Singapore]

The Accused pleaded guilty, and was convicted of 2 charges; firstly, of engaging in a conspiracy to possess 695 infringing articles for the purposes of trade under s 136(2)(b) of the Copyright Act read with s 109 of the Penal Code, and secondly of the attempted distribution of 1119 DVDs containing films without a valid certificate under s 21(1)(b) of the Films Act read with Section 511 Penal Code.

The criminal infringement of intellectual property rights carries a high degree of seriousness. It involves not merely the violation of the property rights of another, but generally the exploitation of that violation in order to obtain financial gain. The infringement is therefore generally calculated and deliberate with the intention to obtain profit from the wrongful act. It differs from theft or misappropriation of property because it involves not merely the defalcation of property but its further exploitation.

The seriousness of the offence is underlined by the fact that infringement involves usually offenders working not merely alone, but in groups in a well organised manner. Such concerted effort creates a greater degree of criminality as opposed to most offences involving just a single perpetrator acting alone.

The repercussion of criminal activity goes beyond national boundaries however. There is considerable attention paid to the size and degree of intellectual property right infringement, and the national reputation can be easily imperilled if it is perceived that the law is too lenient in dealing with offenders. Failure to protect property rights adequately can also attract sanctions and detriment for the country concerned.

All of these therefore point to a high degree of seriousness that should be accorded to intellectual property right infringement, and the sentences imposed should accordingly reflect that high degree of seriousness.

Aside from ensuring that the sentences imposed are proportional to the degree of seriousness of the crime, sentences imposed should also deter these criminal acts. The financial incentive to commit such crimes can be great, thereby calling for a significant deterrent element to ensure that persons are fully aware of the high risks of their criminal conduct. The factors pointing to the seriousness of the crime, which have been considered above, are also pointers to deterrent sentences.

This is further reinforced by the fact that that in one sense Intellectual Property crimes can be carried out with greater ease than the theft or misuse of tangible property – all that is required is the reproduction of the design, form or trademark of the targeted item. There is no need to deprive the owner of physical possession. The temptation to exploit will be all the greater then, especially when coupled with the fact that illegal reproduction may be relatively inexpensive. Combating this calls for a deterrent response.

The emphasis on deterrence and seriousness of such crimes has been articulated in various decisions. For instance in a decision of my colleague, DJ Jasvender Kaur in *Tan Wei Ling v PP* she has summarised similar sentiments expressed in England and Hong Kong. She further adds:

Singapore has put in a lot of effort to be an attractive location for intellectual property rights based activities. Singapore too has international obligations to protect the intellectual property rights of proprietors, for example, under the TRIPS Agreement and the United States-Singapore Free Trade Agreement. Similarly, the sentencing policy adopted is to apply a deterrent based policy.

The need for deterrent sentencing, citing the continued commitment of our legislature to protect intellectual property rights has been noted in various decisions, and was underlined particularly in the Ministerial Speech at the 2nd reading of the Copyright (Amendment) Bill:

'Let me therefore take this opportunity to reiterate that the Government's policy is not to condone commission of criminal offences. Because tackling copyright piracy requires a comprehensive approach which involves the enactment of good laws, which we are attempting to do in this exercise, enforcement of stiff penalties and cooperation of the industry as well as constant review of the entire gamut of laws and enforcement. Our courts also have consistently meted out fairly stiff and long term imprisonment for intellectual property offences. I think he would have read this morning, for example, that a proprietor of a shop at Sim Lim Square was sentenced to two years' imprisonment after being caught repeatedly for selling pirated CD-ROMs. I hope the message will be loud and clear that we are not soft on copyright piracy.'

15. *Aggravating factors:* In this judgment the Court took into account as aggravating circumstances the fact that the operation was planned, the scale and diversity of the operation, and the fact that the accused was the mastermind behind the operation.

PUBLIC PROSECUTOR v KOH ENG KIAN

[2007] SGDC 166 [Singapore]

Planned Operation

The accused in the present case had adopted a modus operandi in selling counterfeit goods. He would rent a shop and employ an accomplice to run the shop selling the counterfeit goods. The accomplice would serve as a fall guy who will for all intents and purposes appear to be the person running the shop. In all, the accused set up three shops and he had various accomplices to assist him in manning the shops. The operation is well-planned and the detection of the accused is difficult as he is supervising in the background. In *PP v Tan Fook Sum* [1000] 2 SLR 523, the High Court stated;

'It is well established that where an act is done after deliberation and with premeditation as opposed to the situation where it is done on the spur of the moment and 'in hot blood', that is an aggravating and not a mitigating factor.'

Scale of the Infringing products and diversity in the products offered for sale.

The scale of the accused's business in selling counterfeit products is large. Besides running three shops, the amount of infringing articles in the 12 charges proceeded with and the remaining 23 charges which were taken into consideration for the purpose of sentencing amounted to 9,008 articles. Besides the large scale operation, there is diversity in the products involved. The brands include Sony BMG, Microsoft, Universal, Adobe, Macromedia, Symantec, EMI, Apple Computers, Warner and many others.

Mastermind

The accused had recruited his accomplices to assist him in selling counterfeit products. He had planned the arrangements by getting his accomplices to sign the tenancy agreements for his shops. It is obvious that the accused was trying to avoid detection.

With such a detailed operation involving a group of accomplices, the degree of culpability is higher as compared to an individual operating alone. Moreover, the shops in this case were located in housing estates. The accused had shown a total disregard for the law by operating from busy housing estates. In *Public Prosecutor v Chan Soon Fatt*[2007] SGDC 54 , the court in expressing its disapproval for such brazen conduct stated:

'The conspirators were sufficiently sophisticated as to use a retail shop, brazenly selling their products to the general public in the centre of a major housing estate in Singapore. This was no furtive alley-way operation. That brazenness shows a clear disregard for the law and should be punished accordingly. Furthermore, it fosters an atmosphere of normalcy and tolerance in respect of the infringement of intellectual property rights; the ease of availability of the pirated items promotes its consumption by the public, reduces respect for the law and the rights of others. The openness with which the sales were conducted is clearly at odds with the position of the legislature in promoting and protecting intellectual property rights here.'

SECRETARY FOR JUSTICE v CHOI SAI-LOK

4 HK 334 Hong Kong Court of Appeal

We have no doubt that a distinction should be drawn between the proprietors of retail outlets and warehouses to commit these offences, and the persons employed by them. The former should receive longer sentences than the latter. But where we disagree with the judge is in the distinction which he drew between salesmen on the one hand and couriers on the other. The roles played by storemen, packers, delivery men and salesmen may be different, but we do not see much difference between them in terms of criminal culpability. What will justify differences in sentences between them will be, for example, the number of infringing copies involved, the length of time in which they had been engaged in the trade and factors personal to them such as pleas of guilty.

BORDER MEASURES, TRANSIT AND TRANSHIPMENT

CHAPTER XXV

- A. BORDER MEASURES (1-3)
- B. TRANSIT AND TRANSHIPMENT (4-7)
- C. OTHER NATIONAL POWERS OF TAX AND CUSTOMS OFFICIALS (8)

A. BORDER MEASURES

1. *The TRIPS obligation.* TRIPS requires of Member States to provide for effective border measures to prevent the importation of counterfeit goods in these terms (Art. 51):³⁹⁸

“Members shall, in conformity with the provisions set out below, adopt procedures to enable a right holder, who has valid grounds for suspecting that the importation of counterfeit trademark or pirated copyright goods may take place, to lodge an application in writing with competent authorities, administrative or judicial, for the suspension by the customs authorities of the release into free circulation of such goods.

Members may enable such an application to be made in respect of goods which involve other infringements of intellectual property rights, provided that the requirements of this Section are met.

Members may also provide for corresponding procedures concerning the suspension by the customs authorities of the release of infringing goods destined for exportation from their territories.”

Customs officials have, obviously, other legal remedies at their disposal that do not depend on the TRIPS Agreement in order to detain certain counterfeit goods, depending on the nature of counterfeiting. The goods may not comply with other laws such as health and environmental regulations. They may have been fraudulently marked. In all such cases customs may act *ex officio* and does not depend on the rights holder to act.

2. *Qualifications.* The right to a holding order is subject to a number of qualifications, all spelt out in TRIPS, namely (in summary):

- the right holder initiating this procedure is required to provide adequate evidence to satisfy the competent authorities (usually customs) that, under the laws of the country of importation, there is *prima facie* an infringement of the right holder’s intellectual property right;
- the applicant must provide security or an equivalent assurance sufficient to protect the defendant (the alleged infringer) and the competent authorities, and to prevent abuse;
- the importer and the applicant must be promptly notified of the suspension of the release of goods;

398 For a model law on border measures see www.wcoipr.org/wcoipr/gfx/Modellawfinal.doc.d.

- there is a time limit;
- the applicant may be ordered to pay the importer, the consignee and the owner of the goods appropriate compensation for any injury caused to them through the wrongful detention of goods.

3. *An example of how the system works with reference to the EC regulation*³⁹⁹:

NOKIA CORPORATION v REVENUE & CUSTOMS

[2009] EWHC 1903 (Ch) (27 July 2009)

The Counterfeit Goods Regulation concerns customs action against goods suspected of infringing certain intellectual property rights and the measures to be taken against goods found to have infringed such rights. The Regulation was incorporated into national law.

The definition of “goods infringing an intellectual property right” is central to the issues arising on this application.

It can be seen that the Regulation is concerned with three categories of infringing goods, namely “counterfeit goods” which infringe a registered trade mark; “pirated goods” the making of which would have infringed a copyright or design right; and goods which infringe a patent or other miscellaneous rights.

As for “counterfeit goods”, these must bear a mark which is the same or essentially the same as the registered mark and it must be used on goods which are of the same type as those the subject of the registration. It is apparent that this definition includes but is not limited to fakes. It also encompasses the use of the registered mark on goods which are of the same type as those the subject of the registration even if the trade mark holder is not using the mark on those goods himself. It is, however, limited to goods which, by virtue of the fact they bear the offending mark, infringe the trade mark holder’s rights.

Chapter II of the Regulation then sets out a framework in which an application may be made by a rights holder for action by the customs authorities. Even before such an application has been lodged, Article 4 gives customs authorities a power to suspend

399 Council Regulation (EC) No. 1383/2003 of 22 July 2003 concerning customs’ action against goods suspected of infringing certain intellectual property rights and the measures to be taken against goods found to have infringed such rights. The European Commission submitted in May 2011 a proposal for a new regulation concerning customs enforcement of intellectual property rights, aimed at replacing Regulation No. 1383/2003: <http://eur-lex.europa.eu/LexUriServ/LexUriServ.do?uri=COM:2011:0285:FIN:EN:PDF>.

the release of goods pending such an application if, in one of the situations referred to in Article 1(1), it has sufficient grounds for suspecting that goods infringe an intellectual property right. Articles 5 through 8 then set out the procedures for lodging and processing such applications.

Chapter III of the Regulation sets out conditions governing action by the customs authorities. They are of considerable importance and begin with an obligation on a customs office to suspend release or detain any goods in one of the situations referred to in Article 1(1) which are suspected of infringing an intellectual property right.

The competent customs body must then inform the rights holder of its action so as to permit the rights holder to establish whether an intellectual property right has been infringed under national law.

The law to be applied in determining that question is addressed by Article 10:

“The law in force in the Member State within the territory of which the goods are placed in one of the situations referred to in Article 1(1) shall apply when deciding whether an intellectual property right has been infringed under national law.”

If the holder or owner of the goods does not abandon the goods for destruction then the Regulation contemplates that the rights holder must initiate proceedings to determine whether an intellectual property right has been infringed under national law.

Goods found to infringe an intellectual property right under national law must be dealt with in accordance with Chapter IV of the Regulation. Most importantly:

Goods found to infringe an intellectual property right at the end of the procedure provided for in Article 9 shall [inter alia] not be allowed to enter into the Community customs territory, released for free circulation, exported, [or] re-exported [etc].

Clearly any power of arrest or detention of goods by HMRC must be exercised in accordance with law. It must have a clear basis for interfering with the property of a third party.

B. TRANSIT AND TRANSHIPMENT

4. *Identifying the problem areas:* Transshipment has been defined in the latest ACTA text as follows:

'transshipment means the customs procedure under which goods are transferred under customs control from the importing means of transport to the exporting means of transport within the area of one customs office which is the office of both importation and exportation.'

The problem of goods being in transit or being trans-shipped relates basically to the powers of the relevant customs officials as set out in local legislation. The general principles set out in this quotation in relation to the EEC apply generally.

A major practical problem in the field of counterfeit goods is that goods enter a country but are not subjected to customs' control because they are destined for another country. Once out of customs' control the goods may then be diverted thereby not only evading customs' duties but also evading customs inspection for purposes of preventing counterfeiting, drug trafficking, weapon smuggling and the like.

There are also other examples: Goods are made in country A and are shipped through country B to country C. If they are counterfeit in all three countries, may the authorities or rights holder act in country B? Or, if they are genuine in country A and C, but counterfeit in country B, may the same parties act in country B?

The problem is serious in relation to generic pharmaceuticals, which are by definition not fakes. These are lawfully manufactured in country A and destined for sale in country C but have to pass through country B.⁴⁰⁰

On the basis that IP rights are territorial and the goods are not intended for the market in country B, the goods, while in transit, cannot infringe an IP right, such a patent right, in country B. This means that, on general principles, goods that are genuinely in transit should not be subject to customs' action in country B. Only if there is reason to believe that the goods might be diverted to the market in country B would customs' action be justified.⁴⁰¹ Any other approach may affect the availability of legitimate goods in especially developing countries.

400 India and the European Union announced on 30 July 2011 that they had entered into a written agreement concerning the powers of EU customs authorities to stop shipments of generic pharmaceuticals passing through Europe. No longer is the existence of an EU patent on passing generics sufficient cause to stop shipments.

401 Xavier Seuba *Border Measures Concerning Goods Allegedly Infringing Intellectual Property Rights* International Centre for Trade and Sustainable Development, working paper, June 2009.

The same rules apply to goods that are counterfeit in all three countries: they are not subject to customs' action in country B but they may be in the exporting and importing countries.

5. *The ECJ.* The position within the European Union is affected by the complications caused by the common market and regulations that some perceive as going beyond what was envisaged by TRIPS.

“All intellectual property international treaties and national intellectual property laws enshrine or implicitly recognize a fundamental principle of intellectual property law, namely, the territoriality principle. According to this principle, intellectual property rights are territorial and its protection depends on each country's national legislation. EC Regulation 1383/2003 hardly reconciles with said principle because in seizing a specific product not intended for the EC market it mandates taking as reference the patent status in the European Member State in which application for customs action is made. Moreover, European Court of Justice (ECJ) jurisprudence on trademarks has traditionally linked right-holders entitlements, in relation to goods in transit, to those products potential diversion into the EC internal market. Thus, the subject-matter of a specific intellectual property right, and the rights of the title holder, would only be affected if IP infringing goods were placed on the internal market. By contrast, against the territoriality principle and against ECJ jurisprudence linking customs actions to the affectation of conferred title holder rights, the mere transit of goods presently permits the title holder to exercise all of its exclusive rights.”⁴⁰²

However, the general approach set out above is reflected in the next judgment quoted. There are other judgments that may give a different impression but they are distinguishable and, if not, they are not to be commended.⁴⁰³

MONTEX HOLDINGS LTD v DIESEL SPA

ECJ, 9 November 2006, C-281/05, ECR 2006, I-10881

Montex manufactures jeans by exporting [from Ireland] the different pieces to Poland, including distinctive signs, under the customs seal procedure, having the pieces sewn together on Polish territory and bringing the completed trousers back to Ireland. Diesel has no protection for the sign in the territory of Ireland.

402 Xavier Seuba *op cit.*

403 *ECJ*, 6 April 2000, *Polo/Lauren*, C-383/98, ECR 2000, I-2519; *ECJ*, 7 January 2004, *Rolex*, C-60/02, ECR 2004, I-651.

Customs Office held back a delivery, intended for Montex, of women's trousers bearing the name 'DIESEL', which a Hungarian company was to transport to them by lorry from the Polish factory through German territory. The trousers were to be transported in uninterrupted transit from the Polish customs office to the customs office in Dublin, and were protected against any removal in the course of transit by a customs seal affixed on the means of transport by the Polish authorities.

Montex filed an objection against the ordering of the detention of the goods in question. It takes the view that the mere transit of goods through German territory does not infringe any of the rights conferred by the trade mark.

Diesel considers, for its part, that this transit constitutes an infringement of its trade mark rights because of the danger that the goods could be marketed in the Member State of transit.

The Court has held that transit, which consists in transporting goods lawfully manufactured in a Member State to a non-member country by passing through one or more Member States, does not involve any marketing of the goods in question and is therefore not liable to infringe the specific subject-matter of the trade mark.

The Court has further made clear that a trade mark proprietor cannot oppose the mere entry into the Community, under the external transit procedure or the customs warehousing procedure, of original goods bearing that mark which have not already been put on the market in the Community previously by that proprietor or with his consent.

It follows that a trade mark proprietor can prohibit the transit through a Member State in which that mark is protected (the Federal Republic of Germany in the present case) of goods bearing the trade mark and placed under the external transit procedure having another Member State as their destination where the mark is not so protected (Ireland in the present case), only if those goods are subject to the act of a third party while they are placed under the external transit procedure which necessarily entails their being put on the market in the Member State of transit.

As has already been held above, the proprietor of a trade mark can prohibit the transit through a Member State in which that mark is protected (the Federal Republic of Germany in the present case) of

goods bearing the trade mark and placed under the external transit procedure with another Member State as their destination where the mark is not so protected (Ireland in the present case), only if those goods are subject to the act of a third party while they are placed under the external transit procedure which necessarily entails their being put on the market in that transit Member State.

Whether the manufacture of the goods in issue was lawful or unlawful is in that respect irrelevant.

6. *Landlocked and island countries:* The judgment next quoted deals with the problem by means of interpreting the local legislation, especially the meaning of the concepts "import" and "export". It concerns the case of goods legitimately made in country A for export to country C where the goods will not be counterfeit. The goods have, however, to pass through country B because the exporting country A is either landlocked or an island where the goods would have been regarded as counterfeit. The question was whether the customs authority in country B could impound the goods on the basis that they had been imported and exported. The court held in the negative.

The position may be different in other countries depending on the legislation. In New Zealand, for instance, all goods arriving in New Zealand by sea or air come under customs' control immediately when they arrive within its territorial limits regardless as to whether they are ultimately destined for domestic consumption or for transshipment outside New Zealand. Bringing goods under customs' control exposes consignments of prohibited or restricted goods to the statutory powers of customs' search, detention, and seizure

AM MOOLLA GROUP LTD v GAP

[2004] ZASCA 112 [South Africa]

The trade mark GAP is registered in 110 countries in the name of one or more of the respondent. In South Africa the respondent holds registrations for the mark in classes 3 and 30 while the marks THE GAP, THE GAP device and GAP device are registered in the name of the appellant in class 25 in respect of clothing.

The respondent sources clothing carrying the GAP trade mark in Lesotho, Swaziland, Zimbabwe, Mauritius and Madagascar (countries where it holds registrations for the mark) destined for marketing in other countries where it also holds registrations. In other words, the source and destination of the goods are countries where the goods are genuine and not counterfeit (ie fraudulent imitations).

The goods from Mauritius and Madagascar have to be trans-shipped via South African harbours and goods from the landlocked countries mentioned have to be transported through South Africa to a harbour. Relying on the appellant's registered trademarks, the appellant has used, attempted to use and threatened to use the provisions of the Act to have the goods in transit impounded by the SA Police Services or the Commissioner of Customs and Excise.

International concern about counterfeiting and piracy led to certain provisions in the TRIPS Agreement, the preamble of which speaks of the desire of Member States:

'to reduce distortions and impediments to international trade, and taking into account the need to promote effective and adequate protection of intellectual property rights, and to ensure that measures and procedures to enforce intellectual property rights do not themselves become barriers to legitimate trade.'

The agreement requires of Member States to provide certain minimum measures for the protection of intellectual property rights but leaves it to them to grant more should they wish to do so. As far as border measures are concerned, art 51 is of significance for present purposes:

'Members shall, in conformity with the provisions set out below, adopt procedures to enable a right holder, who has valid grounds for suspecting that *the importation of counterfeit trademark or pirated copyright goods* may take place, to lodge an application in writing with competent authorities, administrative or judicial, for the suspension by the customs authorities of the release into free circulation of such goods. Members may also provide for corresponding procedures concerning the suspension by the customs authorities of the release of infringing goods destined for exportation from their territories.'

Reverting then to s 2(1)(f) [of the Act], it may be useful to quote the salient wording again:

'goods that are counterfeit goods, may not be imported into or through or exported from or through the Republic'.

For purposes of the present debate it will be assumed that should the respondent, for instance, import GAP clothing into this country, it would amount to a contravention of the provision. The first question

is whether 'transhipment' is included in the words 'imported into' the Republic. Transhipment is a concept well known to the legislature and in ordinary legislative language a distinction is drawn between the two concepts. Interpreting a 1918 statutory provision requiring that a person who 'imports' wheat flour into the country must submit immediately 'after the importation' certain returns and mix it with other flour, our courts have held that the intention of the legislature could not have been to include flour in transit to another country to fall under 'import'

In a local context there may be good reason to wish to provide for remedies to impound counterfeit goods in transit as there would be to impound illegal drugs or weapons in transit. On the other hand, is there any reason to impound goods, which are not in the ordinary sense of the word 'counterfeit', that have to be trans-shipped through this country from island and landlocked countries, especially if no local rights holder is thereby affected and no intellectual property right infringed? Counsel could not suggest any and I cannot conceive of any. One has to assume that this country would not wish to interfere with the legitimate trade of countries that, due to their particular geographical location, are dependent for access and egress on this country. In the light of the preamble of TRIPS quoted above, it is not lightly to be presumed that legislation based on it would 'become barriers to legitimate trade'.

The Act is intended to criminalize a particular species of fraud. What the respondent does can by no stretch of the imagination be considered as fraudulent. Would the Act then wish to criminalize its actions? Since this Act is a penal statute it must be interpreted restrictively without doing violence to the wording. Where, as indicated, the word 'import' need not include transhipment, as the cases referred to indicate, I do not believe that the interpretation contended for by the appellants should prevail.

7. *The transhipment of counterfeit goods:* The approach set out thus far also applies to goods that are fakes: customs may not hold the goods while in transit because they do not infringe a local IP right. Entry of goods for customs procedures such as external transit or customs warehousing is distinguishable from placing them under the customs procedure of release for free circulation.⁴⁰⁴

NOKIA CORPORATION v REVENUE & CUSTOMS

[2009] EWHC 1903 (Ch) (27 July 2009)

This is an application Nokia for judicial review of the decision by Her Majesty's Commissioners of Revenue & Customs ("HMRC"), not to continue to detain or suspend the release of a consignment of mobile phones and accessories which Nokia says are counterfeit; and HMRC's policy whereby goods travelling through the EU from one non-member country to another are not considered to be capable of being counterfeit goods when they do not enter into free circulation in the EU.

HMRC stopped and inspected at Heathrow Airport a consignment of goods being shipped from Hong Kong to Colombia. It comprised approximately four hundred mobile telephone handsets, batteries, manuals, boxes and hand free kits, each of which bore NOKIA trademarks. There is no dispute that the goods comprised in the consignment are indeed fake.

Nokia asked HMRC whether it would be prepared to seize the goods pursuant to its powers under Council Regulation 1383/03 ("the Counterfeit Goods Regulation").

HMRC responded by stating that it had difficulty in understanding how goods could be counterfeit within the meaning of the Counterfeit Goods Regulation unless there was evidence that they might be diverted onto the EU market. In the absence of such evidence HMRC indicated that it did not believe it would be lawful to deprive the owner of its goods.

The issue between the parties is essentially as to the correct interpretation of the definition of "counterfeit goods" in the Counterfeit Goods Regulation and whether it encompasses goods which are in transit and subject to special customs procedures and in circumstances where there is no real prospect of them being released onto the market in the Community.

It is convenient to begin with a consideration of the relevant case law relating to infringement of registered trademarks.

The first is Case C-115/02 *Rioglass and Transremar*[2003] ECR I-12705. It concerned goods lawfully manufactured in Spain and detained in France on suspicion of infringement of trade mark in the course of their transport to Poland. The Cour de Cassation applied for a preliminary ruling as to whether Article 28 EC precluded the

implementation of procedures for detention by customs authorities in a Member State of goods lawfully manufactured in Spain which were intended, following their transport through another Member State, to be placed on the market in a non-member country. The ECJ answered the question in the affirmative and, in doing so, observed:

“With respect to trade marks, it is settled case-law that the specific subject-matter of a trade mark is, in particular, to guarantee to the owner that he has the exclusive right to use that mark for the purpose of putting a product on the market for the first time and thus to protect him against competitors wishing to take unfair advantage of the status and reputation of the trade mark by selling products illegally bearing it.

The implementation of such protection is therefore linked to the marketing of the goods.

Transit, such as that in issue in the main proceedings, which consists in transporting goods lawfully manufactured in a Member State to a non-member country by passing through one or more Member States, does not involve any marketing of the goods in question and is therefore not liable to infringe the specific subject-matter of the trade mark.

That conclusion holds good regardless of the final destination of the goods in transit. The fact that the goods are subsequently placed on the market in a non-member country and not in another Member State does not alter the nature of the transit operation which, by definition, does not constitute a placing on the market.”

The issue arose more directly in *Case C-405/03 Class International BV v Colgate Palmolive Coand Ors*[2005] ECR I-8735 in which Class International shipped into Rotterdam a container load of toothpaste bearing the Aquafresh trade mark from a source in South Africa. The ECJ was asked, in substance, whether the trade mark proprietor is entitled to oppose the introduction into the Community, under the external transit procedure or the customs warehousing procedure, of original goods bearing that mark which had not previously put on the market in the Community by that proprietor or with his consent.

The Court answered that non-Community goods placed under the external transit procedure or the customs warehouse procedure were not to be regarded as “imported” for the purposes of the Trade Marks Directive or the Community Trade Mark Regulation.

Use in the course of trade required introduction of the goods into the Community for the purposes of putting them on the market.

[The court then dealt with *Montex Holdings v Diesel* [2006] ECR I-10881.]

I derive the following principles from all these cases. First, infringement of registered trade mark requires goods to be placed on the market and that goods in transit and subject to suspensive customs procedures do not, without more, satisfy this requirement.

Second, the position is different if the goods in the transit procedure are subject to the act of a third party which necessarily entails their being put on the market (“the *Montex* exception”). But the burden of establishing this rests on the trade mark proprietor.

Third, a mere risk that the goods may be diverted is not sufficient to justify a conclusion that the goods have been or will be put on the market.

Fourth, the Counterfeit Goods Regulation has not introduced a new criterion for the purposes of ascertaining the existence of an infringement of a registered trade mark or to determine whether there is a use of the mark which is liable to be prohibited.

In my judgment identification of the scope of the rights conferred by a registered trade mark as a matter of national law goes a long way to answering the question which arises on this application.

This case was referred to the ECJ for a preliminary opinion by the English Court of Appeal and the ECJ heard it and a related matter originating from Belgium. The ECJ upheld this judgment.

KONINKLIJKE PHILIPS ELECTRONICS NV v LUCHENG MEIJING INDUSTRIAL COMPANY LTD,
and
NOKIA CORPORATION) v HER MAJESTY’S COMMISSIONERS OF REVENUE AND CUSTOMS,

ECJ, 1 December 2011, C-446/09 and C-495/09)

By their questions, which it is appropriate to consider together, the referring courts ask, in essence, whether goods coming from a non-Member State which are imitations of goods protected in the European Union by a trade mark right or copies of goods protected in the European Union by copyright, a related right or a design can be classified as ‘counterfeit goods’ or ‘pirated

goods' within the meaning of Regulation No 1383/2003 and, before the entry into force of that regulation, within the meaning of Regulation No 3295/94 merely on the basis of the fact that they are brought into the customs territory of the European Union, without being released for free circulation there.

According to the definition of the terms 'counterfeit goods' and 'pirated goods' in Article 1(2) of Regulation No 3295/94 and Article 2(1) of Regulation No 1383/2003, they cover infringements of a trade mark, copyright, a related right or a design which applies pursuant to European Union legislation or pursuant to the domestic law of the Member State in which the application for action by the customs authorities is made. It follows that only infringements of intellectual property rights as conferred by European Union law and the national law of the Member States are covered.

In the main proceedings, it is not in dispute that the shavers detained in the port of Antwerp could, where appropriate, be classified as 'pirated goods' within the meaning of Regulation No 3295/94 if they were put on sale in Belgium or in another Member State where Philips holds a copyright and enjoys the design protection on which it relies, or that the mobile telephones inspected at London Heathrow Airport would infringe the Community trade mark relied on by Nokia and would therefore be 'counterfeit goods' within the meaning of Regulation No 1383/2003 if they were put on sale in the European Union. However, the parties to the main proceedings, the Member States which have submitted observations to the Court and the European Commission disagree on whether those goods can infringe those intellectual property rights by reason of the mere fact that they have been the subject, in the customs territory of the European Union, of a declaration seeking one of the suspensive procedures referred to in Article 84 of the Customs Code, namely, in Case C446/09, customs warehousing and, in Case C495/09, external transit.

Having regard to all the foregoing considerations, the answer to the questions referred is that Regulations No 3295/94 and No 1383/2003 must be interpreted as meaning that:

- goods coming from a non-Member State which are imitations of goods protected in the European Union by a trade mark right or copies of goods protected in the European Union by copyright, a related right or a design cannot be classified as 'counterfeit goods' or 'pirated goods' within the meaning of those regulations merely on the basis of the fact that they are brought into the customs territory of the European Union under a suspensive procedure;

- those goods may, on the other hand, infringe the right in question and therefore be classified as ‘counterfeit goods’ or ‘pirated goods’ where it is proven that they are intended to be put on sale in the European Union, such proof being provided, inter alia, where it turns out that the goods have been sold to a customer in the European Union or offered for sale or advertised to consumers in the European Union, or where it is apparent from documents or correspondence concerning the goods that their diversion to European Union consumers is envisaged;
- in order that the authority competent to take a substantive decision may profitably examine whether such proof and the other elements constituting an infringement of the intellectual property right relied upon exist, the customs authority to which an application for action is made must, as soon as there are indications before it giving grounds for suspecting that such an infringement exists, suspend the release of or detain those goods; and
- those indications may include, inter alia, the fact that the destination of the goods is not declared whereas the suspensive procedure requested requires such a declaration, the lack of precise or reliable information as to the identity or address of the manufacturer or consignor of the goods, a lack of cooperation with the customs authorities or the discovery of documents or correspondence concerning the goods in question suggesting that there is liable to be a diversion of those goods to European Union consumers.

C. OTHER NATIONAL POWERS OF TAX AND CUSTOMS OFFICIALS

8. *Powers to search and seize*: To protect the tax base of a country tax or customs laws often provide certain officials the authority to search for and seize counterfeit products. The general scheme in Hong Kong is set out in this judgment.

THE COMMISSIONER OF CUSTOMS AND EXCISE v GOLDEN SCIENCE TECHNOLOGY LIMITED

Hong Kong Court of Appeal

The authority of officers of the Customs and Excise Department to carry out raids in relation to copyright infringement is contained, inter alia, in section 122 of the Copyright Ordinance. An authorized

officer may seize, remove or detain, not only any article which appears to him to be an infringing copy of a copyright work as well as any article which is specifically designed or intended to be used for making such a copy, but also anything which appears to him to be or to contain or to be likely to contain evidence of an offence.

The Court may, first of all, order the article be forfeited.

An alternative course is that the Court may order that the article be delivered to the claimant subject to any conditions. That alternative, however, is not available if the article is either an infringing copy of a copyright work or is designed or adapted to make copies of a particular work. Hence, the alternative of delivering the article to the claimant is effectively only available where it would be evidence of an offence but not, if it is an infringing article.

The third alternative order which the Court may make is disposal of the article in a manner and subject to such conditions as it may specify.

Both of the last two alternatives are subject to any conditions which the Court may impose. Thus, it would be perfectly feasible for a Court to make an order for the temporary delivery of an article to the claimant or for the temporary disposal of an article, for example to the Commissioner of Customs and Excise, subject to conditions as to their production or delivery up in certain circumstances.

Section 132 provides for orders which the Court may make where a person has been charged with an offence. The orders which the Court can make are specifically said to be exercisable whether or not the person charged is convicted of the offence with which he was charged. The Section allows orders to be made not only in respect of infringing copies of copyright works and articles specifically designed or adapted for making copies of particular copyright works but also in respect of articles which have been used in connection with an offence under the Ordinance (again, it would be noted whether or not a conviction has been secured). The orders which the Court may make are that the article may be forfeited to the Crown or it may be delivered up to the person who appears to the Court to be the owner of the copyright concerned or it may be disposed of in such other way as the Court may think fit.

The scheme of the seizure, detention, delivery up and forfeiture provisions of the Ordinance thus appears to provide a speedy resolution of claims and disputes in respect of articles which

have been seized including, if necessary, temporary arrangements pending the exercise by the Court of powers under Section 132 following the hearing of any criminal proceedings.

DISPOSAL OR DESTRUCTION OF INFRINGING AND COUNTERFEIT GOODS

CHAPTER XXVI

- A. INTRODUCTION (1)
- B. ARTICLE 46 (2-4)
- C. ARTICLE 59 (5-10)
- D. THE EUROPEAN DIRECTIVE (11)

A. INTRODUCTION

1. *Introduction:* The TRIPS Agreement contains two provisions relating to the disposal or destruction of goods that have been found to infringe IP rights. The one, Art 46, is of general application, i.e., it applies to the disposal or destruction of infringing goods, irrespective of whether they are counterfeit. The other, Art 59, deals with imported counterfeit goods in the hands of the customs authorities.

The two provisions are interrelated in the sense that Art 59 refers back to Art 46. This has given rise to interpretation difficulties. A Panel Report, prepared under the auspices of the WTO, is invaluable in understanding these provisions and the quotations in this chapter all are taken from that report.⁴⁰⁵

On a practical level there are issues concerning the methods used to dispose of or destroy such goods. These would include environmental issues but they fall outside the scope of this work.⁴⁰⁶

B. ARTICLE 46

2. *The text of Art 46 of TRIPS:*

In order to create an effective deterrent to infringement, the judicial authorities shall have the authority to order that goods that they have found to be infringing be, without compensation of any sort, disposed of outside the channels of commerce in such a manner as to avoid any harm caused to the right holder, or, unless this would be contrary to existing constitutional requirements, destroyed.

The judicial authorities shall also have the authority to order that materials and implements the predominant use of which has been in the creation of the infringing goods be, without compensation of any sort, disposed of outside the channels of commerce in such a manner as to minimize the risks of further infringements.

In considering such requests, the need for proportionality between the seriousness of the infringement and the remedies ordered as well as the interests of third parties shall be taken into account.

405 WTO panel report: *China – measures affecting the protection and enforcement of intellectual property rights* 26 January 2009.

406 WIPO Advisory Committee on Enforcement: David Blakemore *A study relating to existing methods of disposal and destruction of counterfeit goods and pirated goods within the Asia Pacific region* December 2-3, 2010.

In regard to counterfeit trademark goods, the simple removal of the trademark unlawfully affixed shall not be sufficient, other than in exceptional cases, to permit release of the goods into the channels of commerce.

3. *The application of Art 46:* The Article is a general remedy which applies to all types of IP infringement, whether patent, designs, trademarks or copyright. It is as much a remedy as awards of damages or the grant of interdicts or injunctions. By its very nature an order destruction or disposal requires a judicial finding of infringement.

The obligation is to “have” authority not an obligation to “exercise” authority. The phrase “shall have the authority” is used throughout the enforcement obligation in Article 46 that certain authorities “shall have the authority” to make certain orders reflects *inter alia* that orders with respect to specific infringements are left to enforcement authorities’ discretion.

4. *‘Judicial’ authorities have discretion under Art 46:* The discretion to order disposal or destruction is not a free discretion.

- A disposal order should ensure that disposal will be outside of channels of commerce and in a manner that avoids harm to the rights holder;
- If this is not possible destruction should be ordered.

The requirement that authority to order a remedy be “in such a manner as to avoid any harm caused to the right holder” is linked in the text of Article 46 to one remedy only, namely disposal outside the channels of commerce.

The rights holder has to initiate the process. As the Panel said:

A condition that authority shall only be available upon application or request seems to be assumed. This is consistent with the nature of intellectual property rights as private rights, as recognized in the fourth recital of the preamble of the TRIPS Agreement. Acquisition procedures for substantive rights and civil enforcement procedures generally have to be initiated by the right holder and not *ex officio*.

In the exercise of this discretion the judicial authority must consider

- that these remedies are supposed to act as deterrents;
- the issue of proportionality; and
- the interests of third parties such as innocent importers and the public.

There is a limitation on this discretion because, as far as counterfeit trademark goods are concerned, the simple removal of the trademark unlawfully affixed is not sufficient, other than in exceptional cases, to permit release of the goods into the channels of commerce.

C. ARTICLE 59

5. *The text of Art 59:*

Without prejudice to other rights of action open to the right holder and subject to the right of the defendant to seek review by a judicial authority, competent authorities shall have the authority to order the destruction or disposal of infringing goods in accordance with the principles set out in Article 46.

In regard to counterfeit trademark goods, the authorities shall not allow the re-exportation of the infringing goods in an unaltered state or subject them to a different customs procedure, other than in exceptional circumstances.

6. *The scope of Art 59:* This Article is a Customs provision and applies to importation only. This means that it need not be made applicable to goods seized by Customs where those goods are destined for export or are being trans-shipped. The panel held as follows:

Article 59 is found in Section 4 of Part III of the TRIPS Agreement on Special Requirements Related to Border Measures. Section 4 sets out procedures for the suspension at the border by the customs authorities of the release into free circulation of goods. Article 59 sets out the step in these procedures that applies after goods have been found to be infringing. As such, Article 59 forms part of a set of procedures and its key terms must be understood in that context.

Therefore, the Panel finds that there is no obligation to apply the requirements of Article 59 to goods destined for exportation.

In order to be applicable, the goods must be “infringing goods” within the terms of Art 51 which means that they must either be “counterfeit trademark goods” or “pirated copyright goods”.

The first sentence of Article 59 applies to “infringing goods”. The ordinary meaning of these words is not limited to goods that infringe any specific rights. However, read in context, there are certain limitations. The first sentence of Article 51 provides for the relevant procedures to apply, as a minimum, to “the importation” of “counterfeit trademark or pirated copyright goods”. This applies to Article 59.

7. *The procedure:* Initiation of the process leading to disposal or destruction must be by the IP rights holder.

The phrase “shall have the authority” does not require Members to take any action in the absence of an application or request.

Before the Article comes into play there must have been a positive determination by the relevant administrative authority that the goods are counterfeit.

The fact that Article 59 applies to “infringing goods” indicates that the obligations in this Article are triggered when competent authorities find that the goods subject to the suspension are infringing. The fact that Article 59 addresses the authority to order remedies implies that the obligations continue until the time that a remedy has been ordered.

8. *The authority to order disposal or destruction vests in Customs:* The obligation on Member States is to give the necessary authority to customs. There is no obligation on Customs to “exercise” that authority. What it has to do is to exercise its discretion.

Orders with respect to specific infringements are left to enforcement authorities’ discretion.

“Disposal” means disposal “outside the channels of commerce”.

It is not disputed that where competent authorities have authority in any given situation within the scope of Article 59 to order *either* destruction *or* disposal (in accordance with applicable principles), this is sufficient to implement the obligation in the first sentence of Article 59. Therefore, a condition that precludes the authority to

order one remedy (e.g. destruction) could be consistent with Article 59 as long as competent authorities still had the authority to order the other remedy (in this example, disposal).

The responsibility of Customs is to ensure that the manner in which the goods are disposed of outside the channels of commerce is designed (in terms of purpose, not result) in such a way that it will comply with the principle. It may entrust the actual disposal to another body and it is not to be held responsible for acts of such body in carrying out the disposal otherwise than in the authorized manner.

9. *The nature of the discretion:* Discretion has to be exercised in terms of Art 46. These are the principles as identified by the Panel:

- authorities shall have the authority to order disposal or destruction in accordance with the first sentence “without compensation of any sort”; and
- authorities shall have the authority to order disposal “outside the channels of commerce in such a manner as to avoid any harm caused to the right holder”;] or
- authorities shall have the authority to order destruction “unless this would be contrary to existing constitutional requirements”.
- In considering such requests “the need for proportionality between the seriousness of the infringement and the remedies ordered as well as the interests of third parties shall be taken into account”.
- In regard to counterfeit trademark goods, the simple removal of the trademark unlawfully affixed shall not be sufficient, other than in exceptional cases, to permit release of the goods into the channels of commerce.

The discretion not limited to disposal or destruction because these remedies are not exhaustive. The Panel held in this regard:

The obligation that competent authorities “shall have the authority” to order certain types of remedies leaves Members free to provide that competent authorities may have authority to order *other* remedies not required by Article 59. The remedies specified in Article 59 are not exhaustive.

Nothing in the evidence suggests that any harm has ever been caused, or is likely to be caused, to right holders’ reputations due to donation of infringing goods under the measures at issue. In fact, the evidence shows that two internationally famous right

holders have actually participated in the distribution by the Red Cross of goods that infringed their rights, suggesting that they do not presume donation of infringing goods harms their reputation. Therefore, the Panel finds that it has not been demonstrated that Customs lacks authority to donate goods to social welfare bodies in such a manner as to avoid any harm to the right holder caused by lower quality goods.

There is, however, a limitation on discretion: re-exportation may not be used as a method of disposal other than in exceptional circumstances.

The exercise of discretion by the administrative authority must be subject to judicial review.

10. Removal of trademarks: The requirement in Art 46, which also applies to Art 59, namely that simple removal of a counterfeit trademark unlawfully affixed is not sufficient, other than in exceptional cases, to permit release of the goods into the channels of commerce, gave rise to a number of comments by the Panel.

- Where counterfeit trademark goods are released into the channels of commerce after the simple removal of the trademark unlawfully affixed, an identical trademark can be produced or imported separately and unlawfully reattached, often with relative ease, so that the goods will infringe once again.
- This problem applies to counterfeit trademark goods in particular because, as provided in the definition of “counterfeit trademark goods” in footnote 14(a) to the TRIPS Agreement, the counterfeit trademark is *identical* to the valid trademark or cannot be distinguished in its essential aspects from the valid trademark.
- Counterfeit trademark goods are more likely to imitate the appearance of genuine goods in their overall appearance and not simply in the affixation of the counterfeit trademark, as the likelihood that a counterfeit trademark good will confuse a consumer is related to the degree to which all its features, infringing and non-infringing, resemble the genuine good.
- Where the counterfeit trademark is removed, the resulting state of the goods may still so closely resemble the genuine good that there is a heightened risk of further infringement by means of re-attachment of a counterfeit trademark. Whilst this may be true of other, non-infringing goods as well, the goods confiscated by Customs are already counterfeit and are being released into the channels of commerce. The negotiators evidently considered that the heightened risk of further infringement warranted additional

measures to create an effective deterrent to further infringement.

- Counterfeit trademark goods are more likely to imitate the appearance of genuine goods in their overall appearance and not simply in the affixation of the counterfeit trademark, as the likelihood that a counterfeit trademark good will confuse a consumer is related to the degree to which all its features, infringing and non-infringing, resemble the genuine good.
- Where the counterfeit trademark is removed, the resulting state of the goods may still so closely resemble the genuine good that there is a heightened risk of further infringement by means of re-affixation of a counterfeit trademark. Whilst this may be true of other, non-infringing goods as well, the goods confiscated by Customs are already counterfeit and are being released into the channels of commerce. The negotiators evidently considered that the heightened risk of further infringement warranted additional measures to create an effective deterrent to further infringement.
- The Panel notes that the fourth sentence of Article 46, by its specific terms, is not limited to an action to render goods non-infringing, which the simple removal of the trademark would achieve. Rather, the fourth sentence of Article 46 imposes an additional requirement beyond rendering the goods non-infringing in order to deter further acts of infringement with those goods. Therefore, it is insufficient, other than in exceptional cases, to show that goods that have already been found to be counterfeit are later unmarked.
- The Panel considers that the phrase “other than in exceptional cases”, like the rest of the principle set out in the fourth sentence of Article 46, must be interpreted in light of the objective of that Article, namely, “to create an effective deterrent to infringement”. There may well be cases in which the simple removal of the trademark prior to release of the goods into the channels of commerce would not lead to further infringement. For example, an innocent importer who has been deceived into buying a shipment of counterfeit goods, who has no means of recourse against the exporter and who has no means of reaffixing counterfeit trademarks to the goods, might constitute such a case. However, such cases must be narrowly circumscribed in order to satisfy the description of “exceptional”. Even when narrowly circumscribed, application of the relevant provision must be rare, lest the so-called exception become the rule, or at least ordinary.

D. THE EUROPEAN DIRECTIVE

The European Directive No. 2004/48 of 29 April 2004 on the Enforcement of Intellectual Property Rights contains a related provision.⁴⁰⁷ Article 10 provides:

- Without prejudice to any damages due to the right-holder by reason of the infringement, and without compensation of any sort, Member States shall ensure that the competent judicial authorities may order, at the request of the applicant, that appropriate measures be taken with regard to goods that they have found to be infringing an intellectual property right and, in appropriate cases, with regard to materials and implements principally used in the creation or manufacture of those goods.
- Such measures shall include:
 - recall from the channels of commerce;
 - definitive removal from the channels of commerce; or
 - destruction.
- The judicial authorities shall order that those measures be carried out at the expense of the infringer, unless particular reasons are invoked for not doing so.
- In considering a request for corrective measures, the need for proportionality between the seriousness of the infringement and the remedies ordered as well as the interests of third parties shall be taken into account⁴⁰⁸.

407 The European Commission announced, in May 2011, that **Directive No. 2004/48** would be reviewed in the course of 2012.

408 See also, as far as border measures are concerned, Council Regulation No. 1383/2003 concerning customs action against goods suspected of infringing certain intellectual property rights and the measures to be taken against goods found to have infringed such rights, Articles 16 and 17 – see: <http://eur-lex.europa.eu/LexUriServ/LexUriServ.do?uri=OJ:L:2003:196:0007:0014:EN:PDF>.

A proposal of a new Regulation has been submitted by the European Commission in May 2011, aimed at replacing Regulation No. 1383/2003.



For more information contact WIPO at www.wipo.int

World Intellectual Property Organization (WIPO)

34, chemin des Colombettes

P.O. Box 18

CH-1211 Geneva 20

Switzerland

Telephone:

+4122 338 91 11

Fax:

+4122 740 54 28